



# LiFePO<sub>4</sub> Instruction Manual

LFP12V50B | LFP12V100B | LFP12V200B  
50Ah | 100Ah | 200Ah

## CONTENTS

FEATURES.....	3
SAFETY CHARACTERISTICS.....	3
CHARGING.....	5
MAINTAINING THE BATTERY.....	5
INSTALLATION.....	5
COMPETITIVE INFORMATION.....	6
BATTERY SPECIFICATIONS.....	7
CELL SPECIFICATIONS.....	8
DC WIRING DIAGRAM.....	12
BLUETOOTH INSTRUCTIONS.....	13
WARRANTY.....	16

# Lithium LiFePO<sub>4</sub> Battery 12V

## 50Ah | 100Ah | 200Ah

AIMS Power's 12 Volt LiFePO<sub>4</sub> battery product line has a battery for every application. The LiFePO<sub>4</sub> batteries maintain a constant output voltage, providing more efficient power. This allows the cell to deliver virtually full power until it is discharged, and it can greatly simplify or even eliminate the need for voltage regulation circuitry. The battery has a much longer cycle life capacity and easier to maintain compared to other battery technologies. The LiFePO<sub>4</sub> technology has better thermal and chemical stability, which improves battery safety and packed with power in a small and lightweight footprint. Easily uses the same space as your existing 12V battery and replaces lead acid, AGM or Gel battery applications in RVs, boats, commercial vehicles, off grid back up power and much more. Not intended to replace starting batteries.

## FEATURES

- ⊙ Extremely high number of charge/discharge cycles
- ⊙ > 10 Year lifespan with proper maintenance
- ⊙ Bluetooth monitoring
- ⊙ Wide operating temperature range
- ⊙ Temperature protections
- ⊙ IP66 rated - waterproof (model specific)
- ⊙ Low maintenance
- ⊙ High amp capacity
- ⊙ Stable output voltage
- ⊙ Self recovering faults
- ⊙ BMS safety protection
- ⊙ Convenient carry handle
- ⊙ Cell balancing



## SAFETY CHARACTERISTICS

- ⊙ Short circuit protected
- ⊙ Physical damage to battery case will not cause fire
- ⊙ Excessive thermal exposure will not cause a fire
- ⊙ Able to withstand over-charge/over-discharge without damaging the battery
- ⊙ Battery Management System (BMS)

## BMS FUNCTION

Circuit Protection: The battery includes a BMS (Battery Management System) to protect the battery from overcharging, over-discharging, over drain, and short circuit, resulting in overall longer battery life. The BMS also protects the battery from exploding and catching fire. Includes thermal safety fusing, cell balancing, CID and fault recovery. Bluetooth monitoring available.

# WARNINGS



Lithium-ion cells and battery packs may get hot, explode or ignite and cause serious injury if exposed to extreme conditions. Be sure to follow the safety warnings listed below:

- ⦿ Do not connect the positive terminal and negative terminal of the battery to each other with any metal object (such as wire)
  - ⦿ **Only use approved LiFePO<sub>4</sub> battery chargers**
  - ⦿ Do not carry battery while wearing necklaces, rings, bracelets, hairpins or other metal objects
  - ⦿ Do not puncture, strike, or step on the battery
  - ⦿ Do not expose battery to water or salt water, or allow the battery to get wet
  - ⦿ Do not use LiFePO<sub>4</sub> battery with any other types of batteries
  - ⦿ Do not use as starting battery of vehicle
  - ⦿ Do not connect to an alternator or non-smart charging system
  - ⦿ (unless you are using a voltage regulator)
  - ⦿ Do not smoke around or near the battery
  - ⦿ Be careful not to drop heavy tools on the battery
- Keep away from children.

Do not place the battery in or near fire, on stoves or other high temperature locations. Do not place the battery in direct sunlight or use/store the battery inside cars in hot weather. Doing so may cause the battery to generate heat, explode or ignite. Using the battery in this manner may also result in a loss of performance and a shortened life expectancy.

Do not disassemble or modify the battery. The battery contains safety and protection devices, which, if damaged, may cause the battery to generate heat, explode or ignite.

Immediately discontinue use of the battery if, while using, charging or storing the battery, the battery emits an unusual smell, feels hot, changes color or shape, or appears abnormal in any way. Contact AIMS Power if any of these situations occur.

Do not place the battery in a microwave oven, high-pressure container or on induction cookware.

Inspect battery for any damage, cracks, corrosion on terminals. DO NOT USE if you find any damage to the battery.

Use good quality and proper size cables for your application.

## Maximum Battery Wiring Recommendation

Voltage	Series	Parallel	# of Batteries	Max Discharge	Max Load Power
12V	0	4	4	800A	9.6kW
24V	2	4	8	800A	19.2kW
36V	3	4	12	800A	28.8kW
48V	4	4	16	800A	38.4kW

\*The internal Battery Management System is complex and provides extra safety features. Note the max drain per battery specifications.

## CHARGING

Only use battery chargers made for LiFePO<sub>4</sub> batteries. See battery specifications. Improper charging capacity or damage to the BMS may occur.

Ensure the battery cables are tight, secure and have a good connection.

Follow instructions on battery charger.

Use Smart Battery Charger rated for LiFePO<sub>4</sub>.

## MAINTAINING THE BATTERY

Battery should be inspected often.

Ensure cables and terminals are kept clean and free from corrosion, dirt, or build-up of any kind. Use dry cloth to clean.

When possible keep batteries at a moderate temperature.

Dispose of batteries properly. Must be recycled.

Store battery at 50% SOC.

Charge and discharge according to battery specifications.

## INSTALLATION

**Do not reverse the polarity! The battery has safety protections, but damage may occur, and warranty voided.**

Check battery voltage before use. Make sure the battery voltage matches that of the battery charger and load.

Properly size your battery cables for your application.

Battery cables must be crimped or preferably, soldered, and crimped. Soldered connections alone are not acceptable. High quality, UL-listed battery cables are recommended.

Battery terminal must be clean to reduce the resistance between the DC terminal and cable connection.

Do not connect the positive terminal and negative terminal of the battery to each other with any metal object (such as wire).

Install in an environment with minimal heat. Warranty voided for terminal burnout due to excess heat and improper maintenance.

Install in any orientation.

Battery terminal torque – 7.7 – 7.7 Nm

Use proper fusing.

The terminal lugs are in a separate bag within the box.

## COMPETITIVE INFORMATION

Comparing a 100Ah Battery	GEL	AGM	Lead	LiFePO4
Nominal Voltage	12V	12V	12V	12.8V
Charging Voltage	14	14.6	14.8	14.4-14.6
Life Cycles @ 50% DOD	500-600 cycles	500-600 cycles	500-600 cycles	>4000 cycles- no DOD recommended
Constant Output Voltage	No	No	No	Yes
Operating Temperature	-4° F to 140° F	-4° F to 140° F	-4° F to 122° F	-4° F to 149° F
BMS	No	No	No	Yes
Mounting Orientation	Any	Any	Limited	Any
Peak Power	Varies	900A 5secs	Varies	200A 10secs
Capacity	100A	100A	100A	100A
Watt Hours	600 @ 50% DOD	600 @ 50% DOD	600 @ 50% DOD	1280 @ 100%DOD
Weight	71	74	69	31
Parallel Wiring	Yes	Yes	Yes	Yes
Series Wiring	Yes	Yes	Yes	Yes
Recommended DOD	50%	50%	50%	Not applicable
Dimensions-approximate	13" x 7" x 9"	13" x 9" x 7"	13" x 7" x 9"	13" x 6.7" x 9"

## BATTERY SPECIFICATIONS - Lithium Iron Phosphate

Electrical Specifications	LFP12V50B	LFP12V100B	LFP12V200B
Nominal Voltage	12.8V	12.8V	12.8V
Nominal Capacity (at .5C, 77°F)	50Ah	100Ah	200Ah
Minimum Capacity (at .5C, 77°F)	47.5Ah	95Ah	190Ah
Expected Cycle Life	>4000 cycles w/1C charge and discharge rate, at 77°F, 80% DOD		
Operating Specifications			
Charge Method	Smart charger, constant current, constant voltage		
Charge Voltage Range (Max 14.6V)	14.4 -14.6V		
Continuous Charge Current	50A Max	100A Max	200A Max
Charge Temperature	32° F to 113° F		
Charge Temperature Protection	32° F to 140° F		
Discharge Temperature Protection	-4° F to 140° F		
Continuous Discharge Current	50A Max	100A Max	200A Max
Peak Instant Discharge Current (10 secs)	100A	200A	400A
Over Charge Current Protection	70A ±10A	160A ±10A	440A ±40A
Discharge Current Protection	110A ±10A	220A ±20A	490A ±40A
Over Voltage Shutdown	15.2 ±.5V		
Discharge Cut-off Voltage	8V ±.5V		
Operating Temperature	-4° F to 158° F ±18° F		
Storage Temperature	-20° F to 176° F		
Self-Discharge (stored at 50% SOC)	< 3%/month		
Watt Hours	600 Watt hours	1280 Watt hours	2560 Watt hours
Physical Specifications			
Battery Dimensions	9"L x 5.4"W x 8.2"H-9" with terminals	12.75"L x 6.5"W x 8.3"H-9" with terminals	20.5"L x 10.6"W x 8.7"H-9" with terminals
Weight	15.8 lb	27.5 lb	62 lb
Shipping Weight	18 lb	31 lb	66 lb
Group Size	1250	31	4D
Post to Post Measurement	7"	10.43"	5"
Battery Post Size	5/16" M8 1.3" long	5/16" M8 1.9" long	5/16" M8 1.7" long
BMS Operation			
Over Charge Protection	Over charge detection voltage: 3.8 ± .05V		
	Over charge detection delay time: 0.96 - 1.4s		
	Over charge release voltage: 3.60 ±.05V		
	Maximum charge voltage: 3.65 ±.05V		
Over Discharge Protection	Over current: 50AMP160A ±10A		
	Over discharge detection voltage: 2.0V ± .05V		
	Over discharge detection delay time: 0.96-1.4s		
	Over discharge release voltage: 2.3V ± .10V		

Over Current Protection	Over current detection delay time: $9 \pm 2s$		
	Over current release condition: Cut load		
Short Circuit Protection	Yes		
Cell Balancing	Balance Detect Voltage: 3.2V Current: $30 \pm 5mA$		
Warranty (Limited)	10 Year	10 Year	10 Year

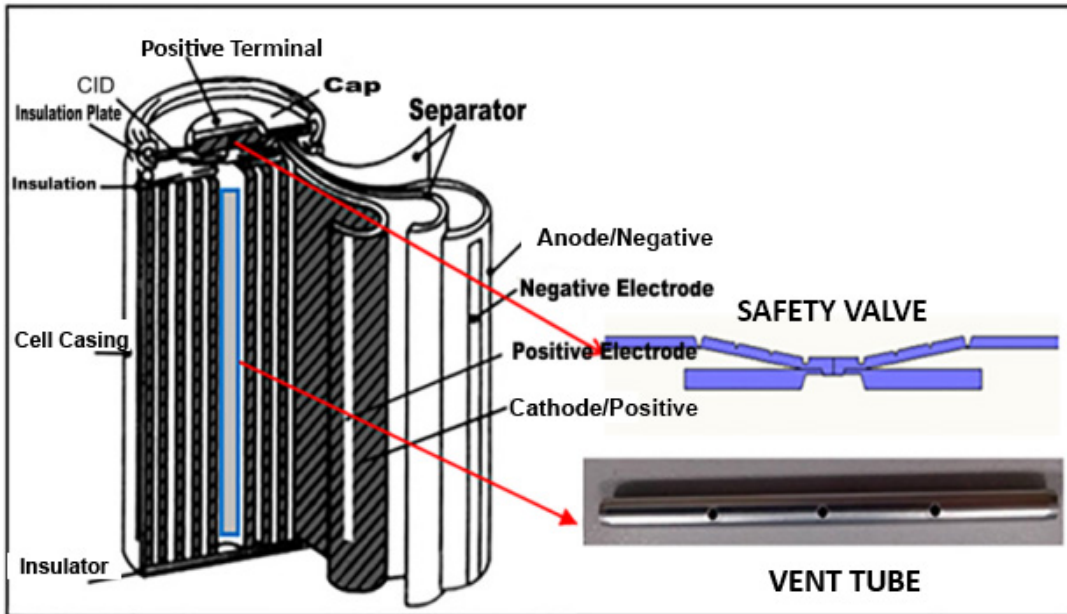

### VENT TUBE

Under the conditions of the battery's chemical reaction, the internally generated gas gathers in the ventilation tube through the vent hole and the upper and lower openings, which is conducive to the internal gas dispersion of the battery, to ensure the internal pressure balance of the battery cell, and to avoid potential safety hazards of the battery cell.

### SAFETY VALVE

When the internal pressure reaches  $1.2 \pm 0.1Mpa$ , the positive electrode tab and the cap are disconnected to stop the internal chemical reaction of the battery; when the internal pressure reaches  $1.8 \pm 0.1Mpa$ , the safety valve will open, and the gas will discharge to avoid the risk of explosion.



# BATTERY CELL CYCLE PERFORMANCE

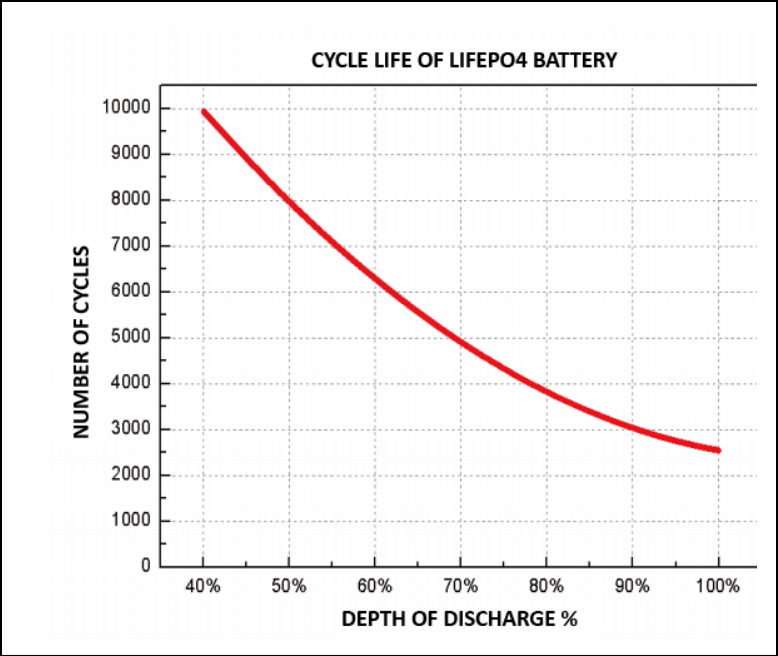
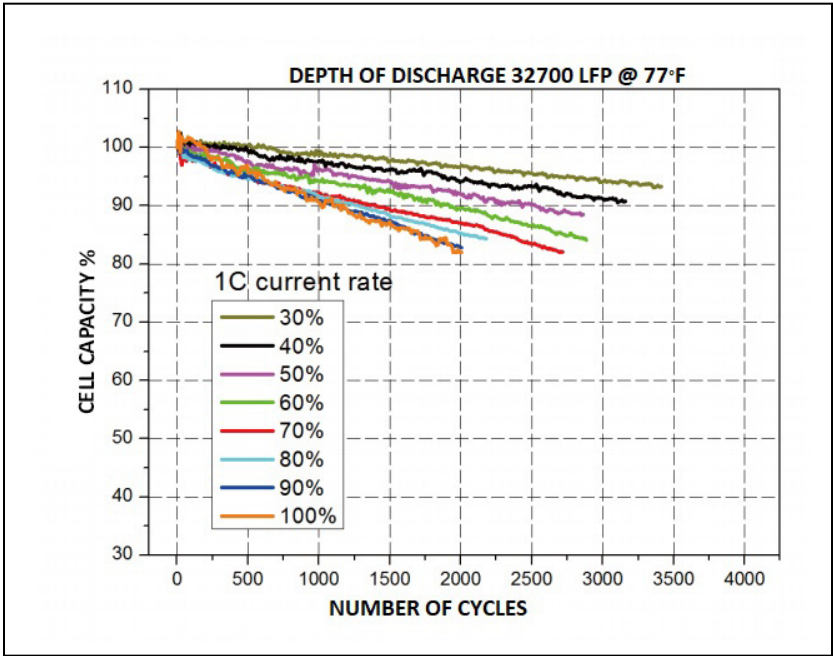

As the depth of discharge decreases, the cycle life gradually increases; 1C 100% DOD charge and discharge cycle life  $\geq$  2500 cycles; 1C 50% DOD charge and discharge cycle life  $\geq$  6000 cycles.

## BATTERY CELL CYCLE PERFORMANCE @ .5C & 1C

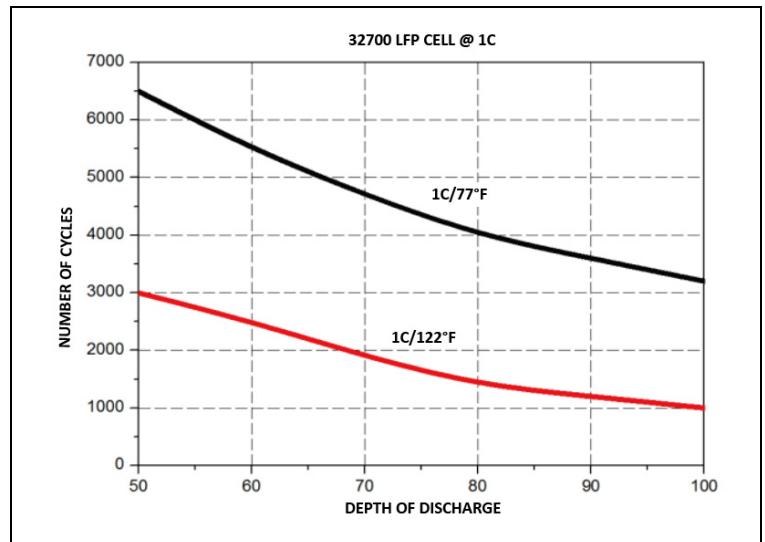
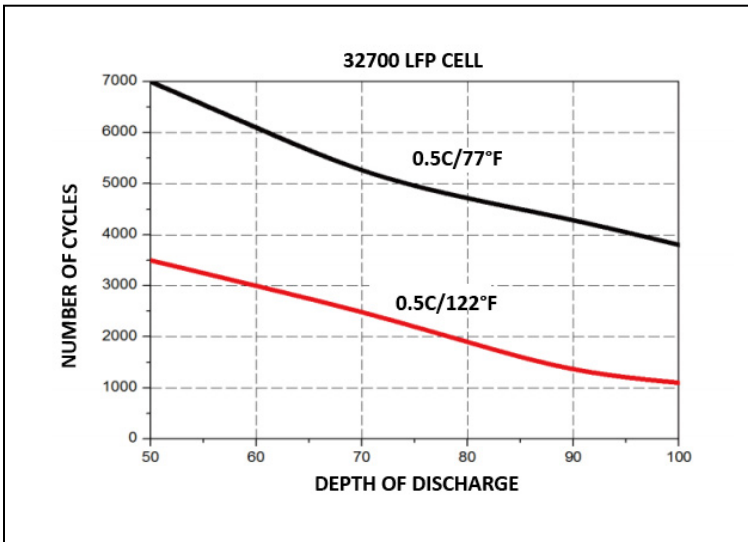

At high temperatures, the SEI film decomposes, cracks, or dissolves, resulting in continuous consumption of lithium ions and rapid decline in capacity.

At low temperatures, the active substance in the battery is low, the internal resistance and viscosity of the electrolytes are increased, the ion diffusion rate is slowed down, and  $\text{Li}^+$  is more difficult to intercalate and easily disengage, which causes the capacity to decrease rapidly.

## CELL SPECIFICATIONS

Model	32700
Standard Capacity	6AH
Rated Voltage	3.2V
Max Charge Voltage	3.65V
Discharge Cut-off Voltage	2.3V
Standard Charge Current	5A
Max Continuous Discharge Current	15A
Peak Instant Discharge Current	30A (10 Secs)
Dimension (Customized)	32*70mm
Weight (Approx.)	About 160g
Operating Temperature	-4°F~149°F
Built-in Protection Circuit Module	YES
Cycle Time	4000 times at 1C, 70% DOD
32700 3.2V 6000mAh	Diameter: 32.2mm Height: 70mm



Celsius	Fahrenheit	Usable Capacity
60	140	Usable but not recommended
50	122	≥102%
40	104	≥100%
30	86	≥100%
20	68	≥97%
10	50	≥90%
0	32	≥85%
-10	14	≥80%
-20	-4	≥65% for 50&100AH, ≥67% for 200AH

# DC WIRING DIAGRAM \*\*\*DC Shunt and inline fuse optional\*\*

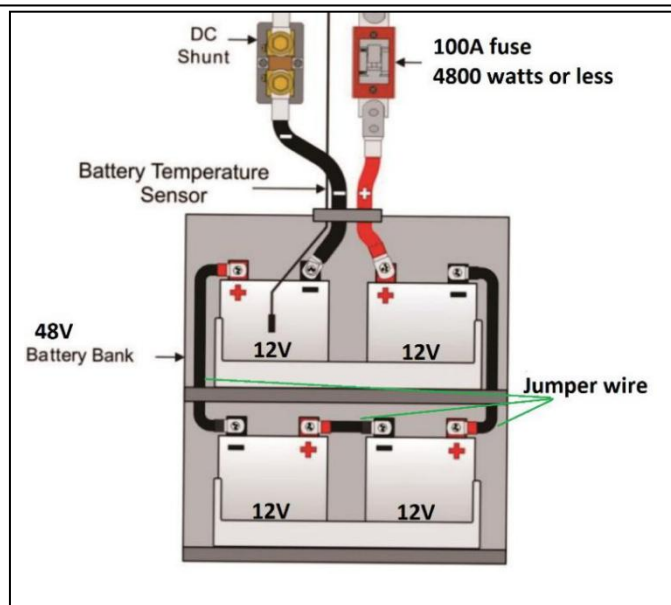
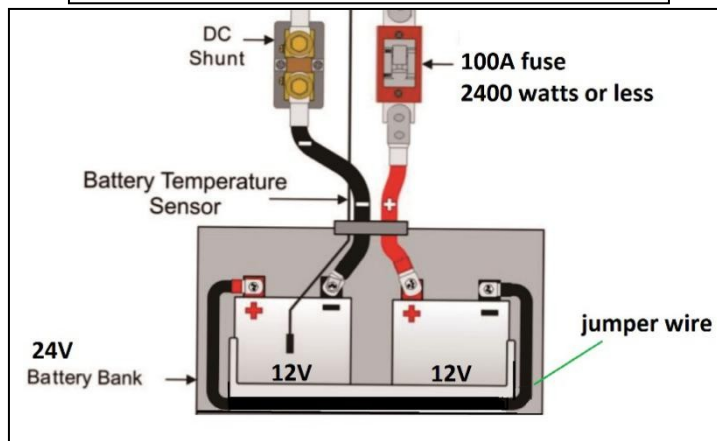
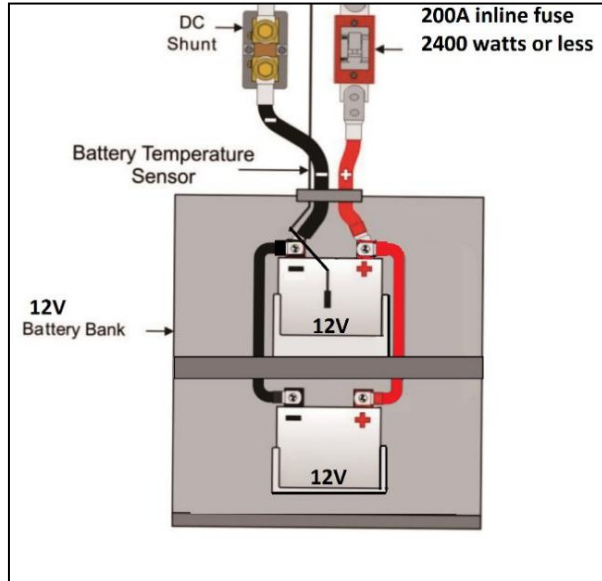

## BLUETOOTH INSTRUCTIONS

By downloading the Android™ or Apple® app on your smartphone or tablet, you can monitor the following information:

- Battery Voltage
- Battery Current (Amps)
- Battery Charge Status(SOC)
- Charge/Discharge State
- Battery Cycles
- Battery Temperature
- Remaining Capacity (RMC)
- Design Capacity (DCAP)
- Full Charge Capacity (FCC)
- Average Time: Empty/Full

## CONNECTION TO THE BATTERY

Make sure you have the latest version of AIMS BATB app that can be found on Google Play for Android and the

App Store for Apple (IOS). Turn on your Bluetooth. Tap the AIMS BATB icon  to open the app. It will search for all AIMS' smart batteries within range of your Bluetooth device and a list of batteries will appear. If your batteries are not listed, move closer to the battery location and swipe your finger from top to bottom on the APP. This will refresh the screen. Once the battery list is displayed, tap the battery for more information. You can also search the battery's serial number if your battery bank has several batteries. The serial number is located on the battery. Note: The app can only communicate with one battery at a time. You must disconnect from one battery to connect to another one (go back to the battery list screen). Also, if any device (such as cell phone or tablet) is connected to a battery, no other device can connect to that battery until the first device disconnects.

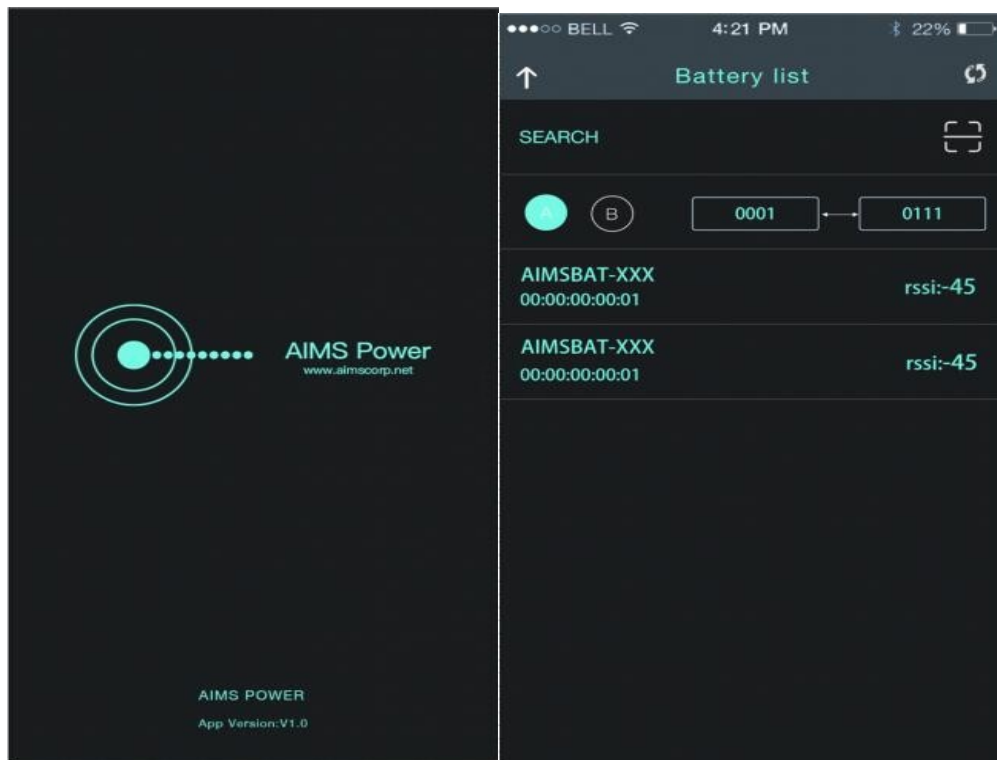

**NOTE:** Screens and data displayed in this manual may change as we continue to make updates to the app as needed.

### BASIC INFORMATION

The second screen displays basic information such as, real-time current and voltage. The State of Charge (SOC) circular graph, like a fuel gauge, displays percentage of remaining charge in the battery. At the bottom of the screen, you will find the battery state and number of charge cycles.

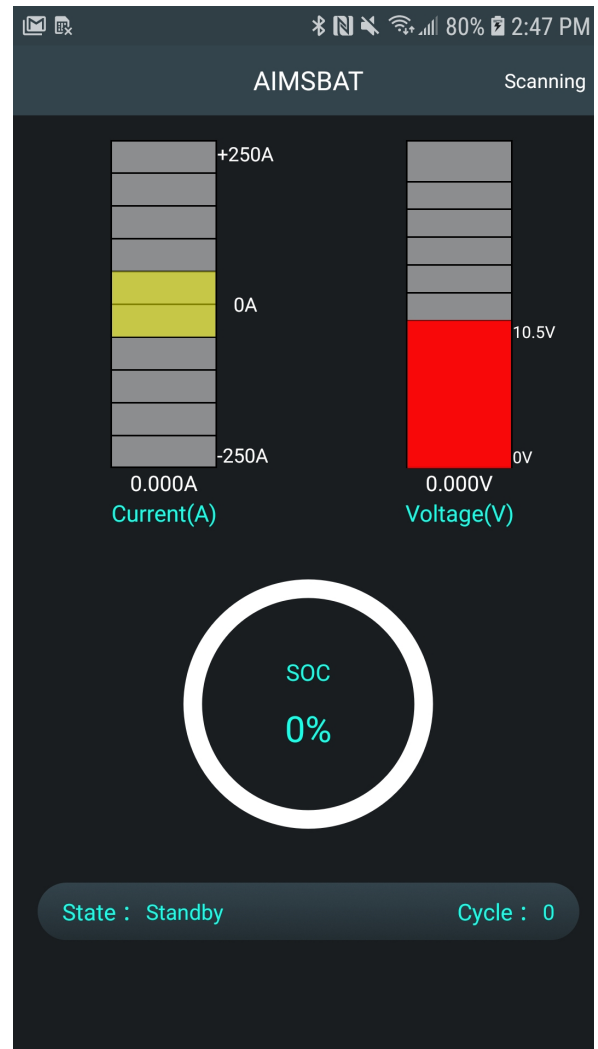

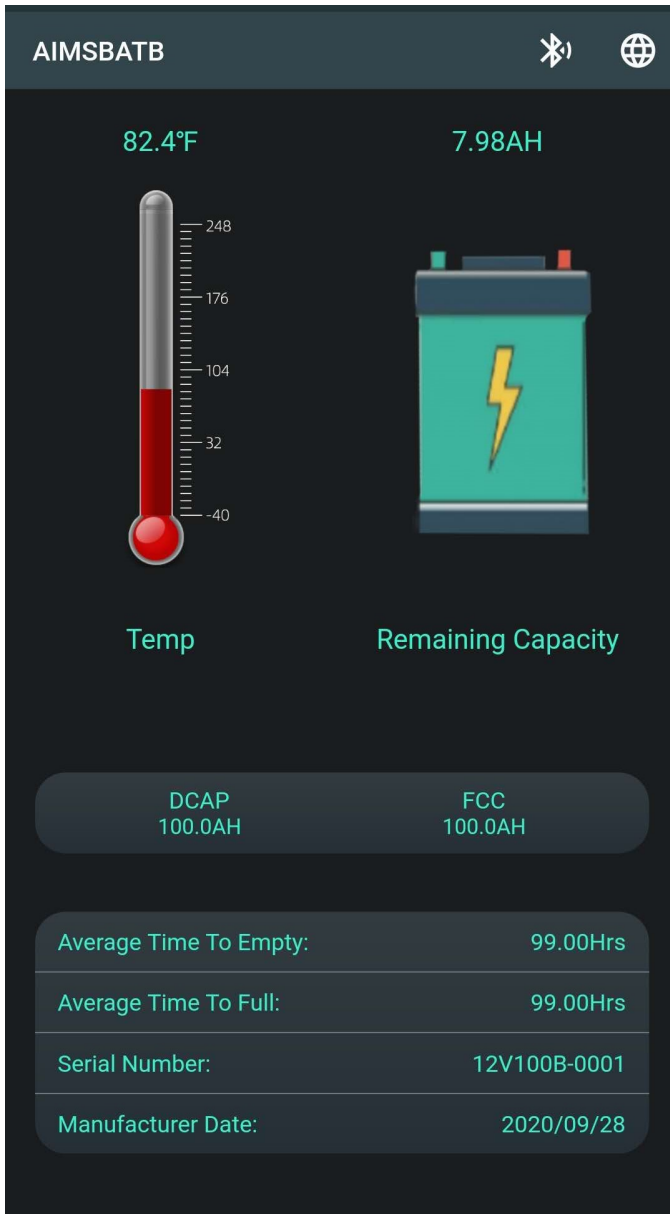

## DETAILED INFORMATION

The next screens display more detailed information. The thermometer shows current temperature. The battery image displays RMC (Remaining Capacity). You will also find DCAP (Design Capacity), FCC (Full Charge Capacity), Average Time to Empty (ATTE) and Average Time to Full (ATTF), serial # and date.