



## AGM12V200AH 12V 200Ah(20hr)

The AIMS Power AGM maintenance free batteries are lead-lead dioxide technology. The dilute sulfuric acid electrolyte is absorbed by separators and plates and thus immobilized. Should the battery be accidentally overcharged producing hydrogen and oxygen, special one-way valves allow the gases to escape, avoiding excessive pressure build-up. The battery is completely sealed, maintenance-free, and leak proof. Usable in any orientation.



### Battery Construction

Component	Positive plate	Negative plate	Container	Cover	Safety valve	Terminal	Separator	Electrolyte
Raw material	Lead dioxide	Lead	ABS	ABS	Rubber	Copper	Fiberglass	Sulfuric acid

### General Features

- Absorbent Glass Mat (AGM) technology for efficient gas recombination of up to 99%.
- No electrolyte maintenance.
- No water filling.
- Not restricted for air transport-complies with IATA/ICAO Special Provision A67.
- Recognized component.
- Can be mounted in any orientation.
- Computer designed lead, calcium tin alloy grid for high power density.
- Long service life, float or cyclic applications.
- Maintenance-free operation.
- Low self discharge.

### Dimensions and Weight

Length (mm / inch)	522 / 20.55
Width (mm / inch)	238 / 9.37
Height (mm / inch)	218 / 8.58
Total Height (mm / inch)	223 / 8.78
Approx. Weight (Kg / lb)	63 / 138.9

\* Weight deviation: ± 3%

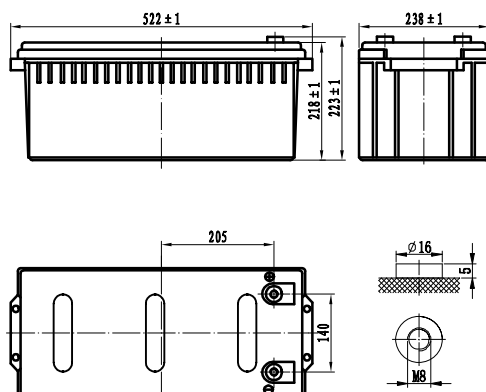

### Performance Characteristics

Nominal Voltage	12V
Number of Cells	6
Design Life	10 years
Nominal Capacity 77°F(25°C)	
20 hour rate (10.0A, 10.8V)	200Ah
10 hour rate (18.7A, 10.8V)	187Ah
5 hour rate (35.8A, 10.5V)	179Ah
1 hour rate (126A, 9.6V)	126Ah
Internal Resistance	
Fully charged battery 77 °F(25°C)	≤ 4.0mOhms
Self-Discharge	
3% of capacity loss per month at 20 °C(average)	
Operating Temperature Range	
Discharge	-20~60°C
Charge	-10~60°C
Storage	-20~60°C
Max. Discharge Current 77°F(25°C)	1000A(5s)
Short Circuit Current	3300A
Charge Methods: Constant Voltage Charge 77°F(25°C)	
Cycle use	2.40-2.45VPC
Maximum charging current	60A
Temperature compensation	-30mV/°C
Standby use	2.20-2.30VPC
Temperature compensation	-20mV/°C

### Discharge Constant Current(Amperes at 77°F 25°C)

End Point Volts/Cell		15min	30min	45min	1h	3h	5h	10h	20h
1.60V		350	215	156	126	57.0	38.0	19.1	10.8
1.65V		340	207	150	122	55.0	37.0	19.0	10.6
1.70V		327	201	146	118	54.5	36.4	18.9	10.4
1.75V		310	195	142	115	52.9	35.8	18.8	10.2
1.80V		261	182	137	112	50.5	35.2	18.7	10.0

### Discharge Constant Power (Watts at 77°F 25°C)

End Point Volts/Cell		15min	30min	45min	1h	2h	3h	5h
1.60V		607	392	288	227	137	108	72.6
1.65V		586	380	280	222	135	106	71.6
1.70V		569	373	274	218	132	104	70.8
1.75V		561	363	269	214	128	100	69.9
1.80V		538	355	265	212	125	97.0	69.0

(Note) The above characteristics data are average values obtained within three charge/discharge cycles not the minimum values. All data may be changed without notice.

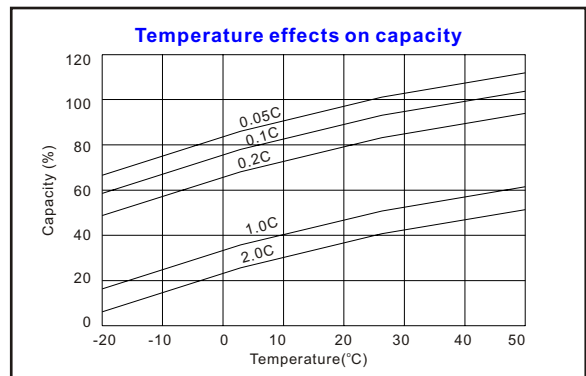
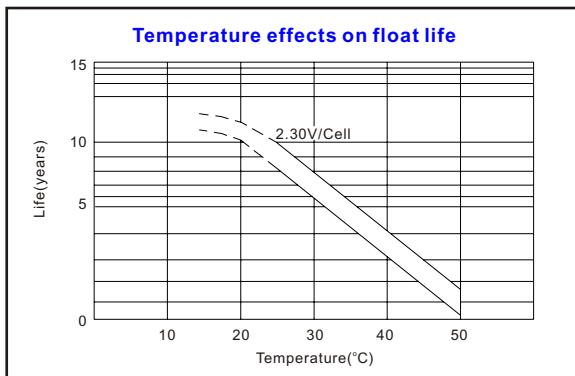
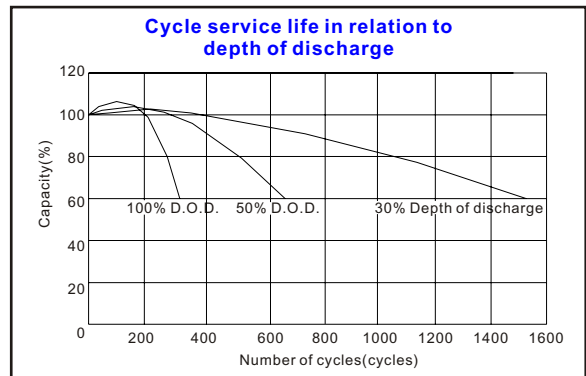
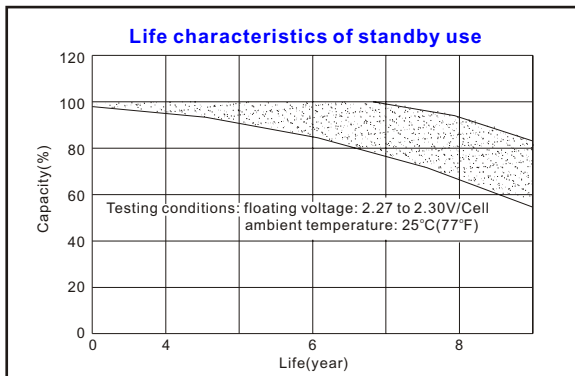
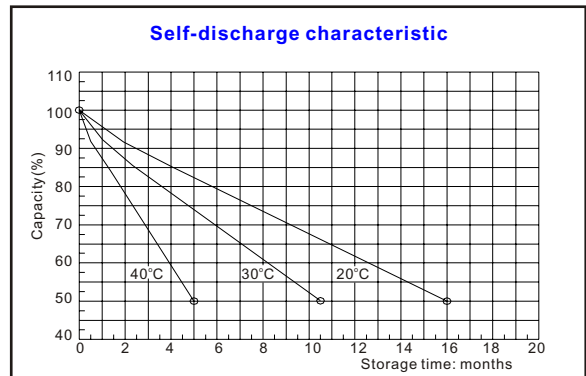
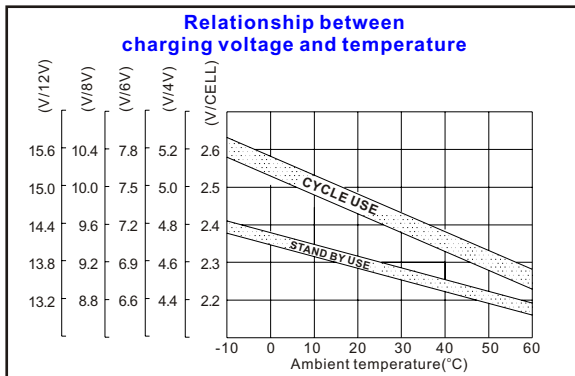
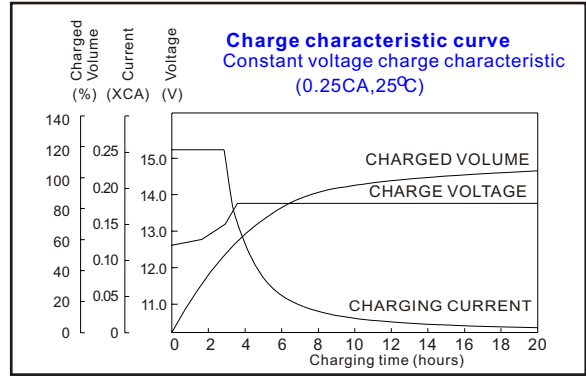
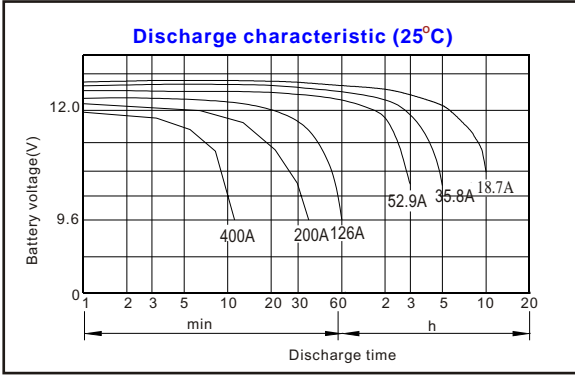

G4M19906-9202-E-16