



Renogy

Pure Sine Wave Inverter

12V | 700W/1000W/2000W/3000W

VERSION A2

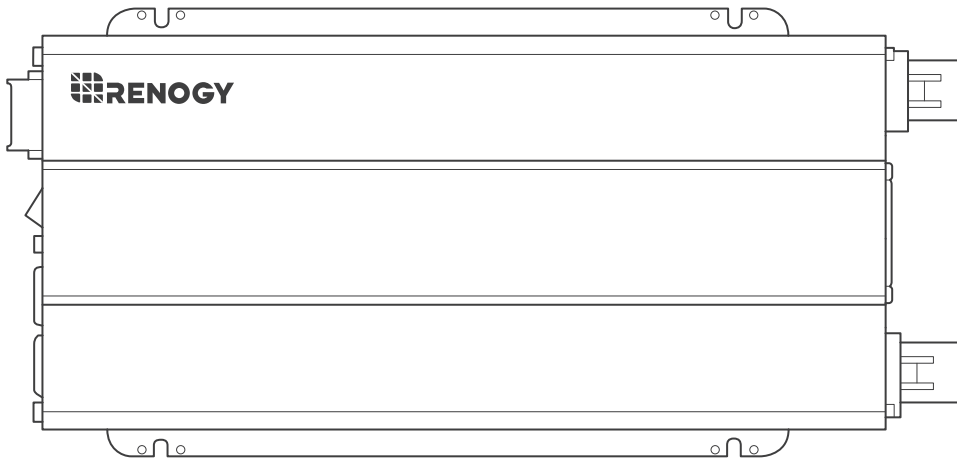

USER MANUAL

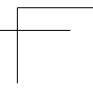
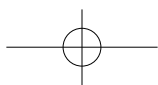
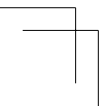
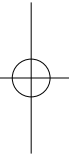
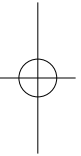
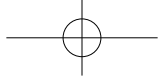
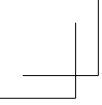

Applicability

The user manual applies to the following products:

- 700W 12V Pure Sine Wave Inverter (RNG-INVT-700-12V-P2)
- 1000W 12V Pure Sine Wave Inverter (RNG-INVT-1000-12V-P2)
- 2000W 12V Pure Sine Wave Inverter (RNG-INVT-2000-12V-P2)
- 3000W 12V Pure Sine Wave Inverter (RNG-INVT-3000-12V-P2)

Disclaimer

- Renogy ensures the accuracy, sufficiency, and the applicability of information in the user manual at the time of printing due to continual product improvements that may occur.
- Renogy assumes no responsibility or liability for personal and property losses, whether directly and indirectly, caused by the user's failure to install and use the product in compliance with the user manual.
- Renogy is not responsible or liable for failures, damages, or injuries resulting from repair attempted by unqualified personnel, improper installation and operation.
- The illustrations in the user manual are for demonstration purposes only. Details may appear slightly different depending on product revision and market region.
- Renogy reserves the right to change the information in the user manual without notice. For the latest user manual, visit [renogy.com](https://www.renogy.com).

Copyright

12V 700W/1000W/2000W/3000W Pure Sine Wave Inverter User Manual @ 2022 Renogy. All rights reserved.

All information in the user manual is subject to copyright and other intellectual property rights of Renogy and its licensors. The user manual may not be modified, reproduced, or copied, in whole or in part, without the prior written permissions of Renogy and its licensors.

Trademark

The following are registered trademarks of Renogy:

RENOGY	RENOGY
--------	---------------

The registered trademarks in the user manual are the property of Renogy. The unauthorized use of the trademarks is strictly prohibited.

Date and Revision

February 2023, Revision A2

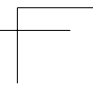
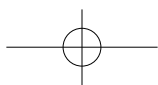
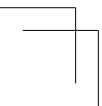
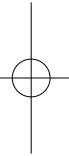
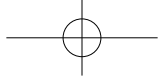
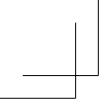

Table of Contents

Important Safety Information	01
Symbols Used	01
General Safety Information	01
Introduction.....	03
General Information	03
Key Features.....	03
Pure Sine Wave	04
Package Contents	05
Product Overview	06
700W Inverter.....	06
1000W Inverter.....	08
2000W or 3000W Inverter.....	10
Wiring Diagram.....	12
700W Inverter	12
1000W Inverter.....	14
2000W or 3000W Inverter	16
Installation	18
Plan an Installation Site.....	18
Size a Battery Bank.....	19
Ground	20
DC Wiring.....	20
AC Wiring	22
Operation.....	24
Operations on Inverter	24
Wired Remote Control.....	24
LED Overview.....	25
Troubleshooting.....	26
Dimensions.....	27
700W Inverter	27

1000W Inverter	27
2000W Inverter	28
3000W Inverter	28
Specifications	29
General Data	29
Electrical Data	29
Wired Remote Data	30
Technical Support	31

Important Safety Information

Symbols Used

General Safety Information

The user manual provides important installation, operation, and maintenance instructions for 12V 700W/1000W/2000W/3000W Pure Sine Wave Inverter. Please read the user manual carefully before installation and operation and save it for future reference.

Failure to observe the instructions or precautions in the user manual can result in electrical shock, serious injury, or death, or can damage the inverter, potentially rendering it inoperable. The installation and service of the inverter might require knowledge of electricity and is recommended to be carried out by qualified personnel.

Symbols Used

The following symbols are used throughout the user manual to highlight important information:



WARNING

Indicates a potentially dangerous condition which could result in injury or death.



CAUTION

Indicates a critical procedure for safe and proper installation and operation.



NOTE

Indicates an important step or tip for optimal performance.



INFO

Indicates that more information is available in other documents relating to the subject.

General Safety Information



WARNING

- Have the inverter installed by a qualified technician in accordance with the local and national electric codes (NEC).
- There are no serviceable parts for this inverter. Do not disassemble or attempt to repair the inverter.
- Ensure all connections going into and from the inverter are tight. There may be sparks when making connections; therefore, there should not be flammable materials or gases near the installation site.
- The inverters are suitable for 12V battery banks ONLY.
- Always ensure the inverter is in OFF position and disconnect all AC and DC devices associated with the inverter.
- Never connect the AC output of the inverter directly to an Electrical Breaker Panel or Load Center which is also fed from the utility power or generator.
- Please confirm the polarity of the devices before connection. A reverse polarity contact can cause injury and damage the device.
- Be careful when touching bare terminals of capacitors as they may retain high lethal voltages even after power is removed.

Important Safety Information

Symbols Used

General Safety Information

- Do not let the positive (+) and negative (-) terminals of the battery touch each other. Use only deep-cycle sealed lead-acid, flooded, gel, or lithium batteries.
- Risk of explosion! Never install the inverter in a sealed enclosure with flooded batteries! Do not install in a confined area where battery gases can accumulate.
- Be careful when working with large lead acid batteries. Wear eye protection and have fresh water available in case there is contact with the battery acid.
- Overcharging and excessive gas precipitation may damage the battery plates and activate material shedding on them. Too high of an equalizing charge or too long of one may cause damage. Carefully review the requirements of the specific battery in use.



CAUTION

- Install the inverter in a well-ventilated, cool, and dry environment. Make sure the fans of the inverter and the ventilation holes are not blocked.
- Do not expose the unit to rain, moisture, snow, or liquids of any type.

Introduction

General Information

Key Features

Pure Sine Wave

General Information

Renogy 12V 700W/1000W/2000W/3000W Pure Sine Wave Inverter (hereinafter referred to as inverter) is perfect for most off-grid systems, whether for a van, semi-trucks, fifth wheels, cabin, or any remote location needing power. The inverter converts DC Power stored in batteries into usable AC Power for appliances. The advanced Renogy pure sine wave technology will allow you to power just about any AC appliance without risk of damage to even your most sensitive equipment.

Key Features

- **Powerful DC-AC Conversion**

Continuous rated output power with a conversion efficiency greater than 90%, and up to 2x surge for start-up loads.

- **Safe for Use**

Integrated GFCI, overload, overtemperature, overvoltage, short-circuit, and undervoltage protection.

- **Guaranteed Protection on Appliances**

Pure sine wave technology is similar if not better than grid power and can extend appliance life by providing a smooth sine wave so as to not damage it. No strange buzzing sounds and your devices can run smoothly.

- **Ease to Use**

Offers a built-in 5 V/2.1 A USB port, AC Outlet(s), Hardwired AC Output Terminal Block, and a Wired Remote Port.

- **Reliable Quality**

ETL listed to CSA Standard C22.2 No. 107.1 and UL 458.

Introduction

General Information

Key Features

Pure Sine Wave

Pure Sine Wave

The inverter outputs a pure sine wave similar to the waveform of the grid power. In a pure sine wave, the voltage rises and falls in a smooth fashion with very low harmonic distortion and cleaner utility-like power.

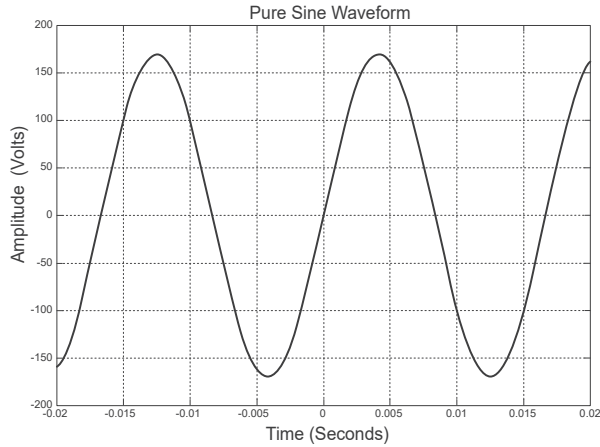

This technology allows the inverter to supply electronic devices that require a high quality waveform with little harmonic distortion. In addition, the technology enables the inverter to be more efficient than traditional ones, allowing you to use less energy to supply more devices. The inverter can provide sufficient, stable power for tools, fans, lights, computers, and other electronics without any interference.

Package Contents

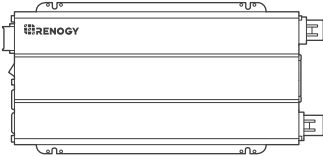
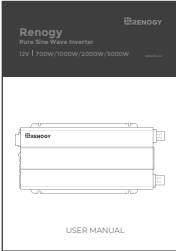
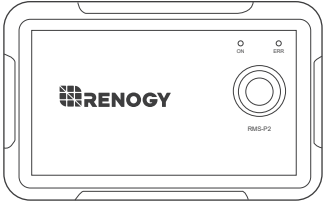
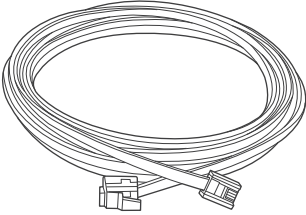
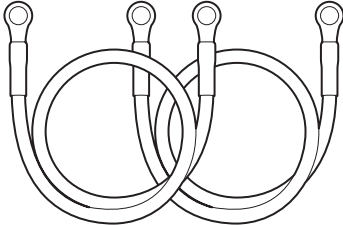
12V Pure Sine Wave Inverter x 1	User Manual x 1
	
Wired Remote Control x 1	RJ11 Network Cable (5m) x 1
	
Cable x 2	
	<ul style="list-style-type: none">• 700W Inverter (RNG-INVT-700-12V-P2): 6 AWG @ 3 ft• 1000W Inverter (RNG-INVT-1000-12V-P2): 4 AWG @ 3 ft• 2000W Inverter (RNG-INVT-2000-12V-P2): 1/0 AWG @ 3 ft• 3000W Inverter (RNG-INVT-3000-12V-P2): Not included

Product Overview

700W Inverter

1000W Inverter

2000W or 3000W Inverter

700W Inverter

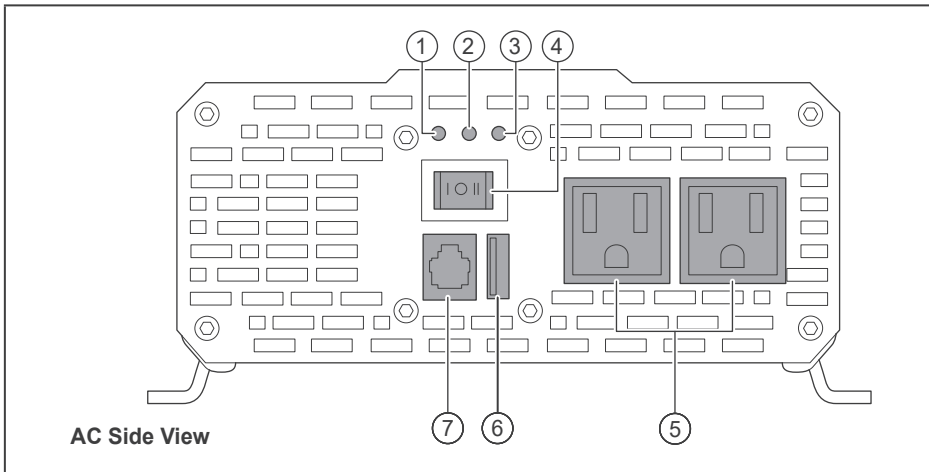

No.	Part	Description
1	Power LED (Green)	Indicates the operation status of the inverter.
2	GFCI LED (Yellow)	Indicates that the ground fault circuit has been interrupted. In such case, restart the inverter.
3	Fault LED (Red)	Indicates that the inverter shuts down due to overheating, overload, undervoltage, or overvoltage. Solution: Immediately turn off all AC appliances. Allow the inverter to cool before continuing. Make sure that the ventilation vents are not blocked. If an inverter shutdown was preceded by a buzzing sound, there may be an excessive load in combination with low voltage or a cable problem.
4	ON/OFF/REM Switch	Turns inverter ON, OFF, or REMOTE.
5	AC Outlets	115V AC 60 Hz: <ul style="list-style-type: none"> Up to 15 A for 2000W and 3000W models Up to 8.7 A for 1000W models Up to 6.1 A for 700W models
6	USB Power Port	Supplies 5V/2.1 A for charging tablets, smartphones, and other small appliances.
7	Remote Control Terminal	Connects to the Wired Remote Control.

Product Overview

700W Inverter

1000W Inverter

2000W or 3000W Inverter

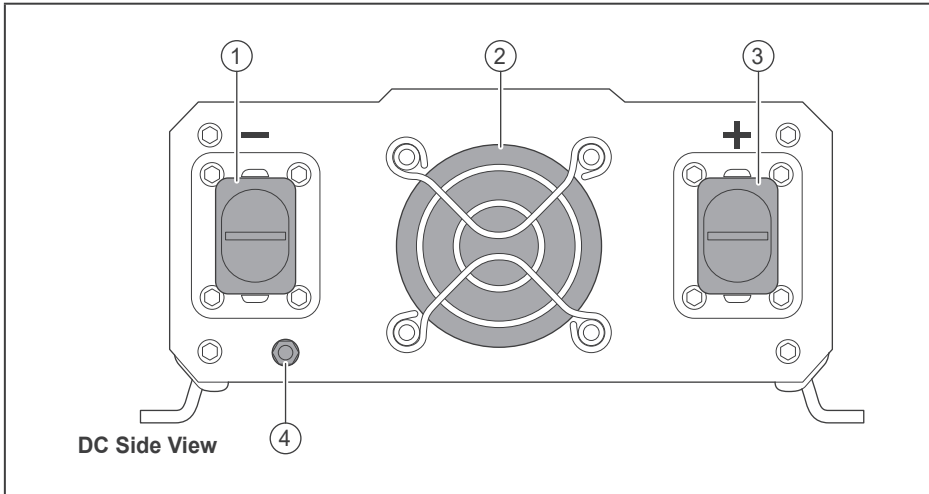

No.	Part	No.	Part
1	Negative (-) DC Input, M8	3	Positive (+) DC Input, M8
2	Cooling Fan	4	Ground, M4

Product Overview

700W Inverter

1000W Inverter

2000W or 3000W Inverter

1000W Inverter

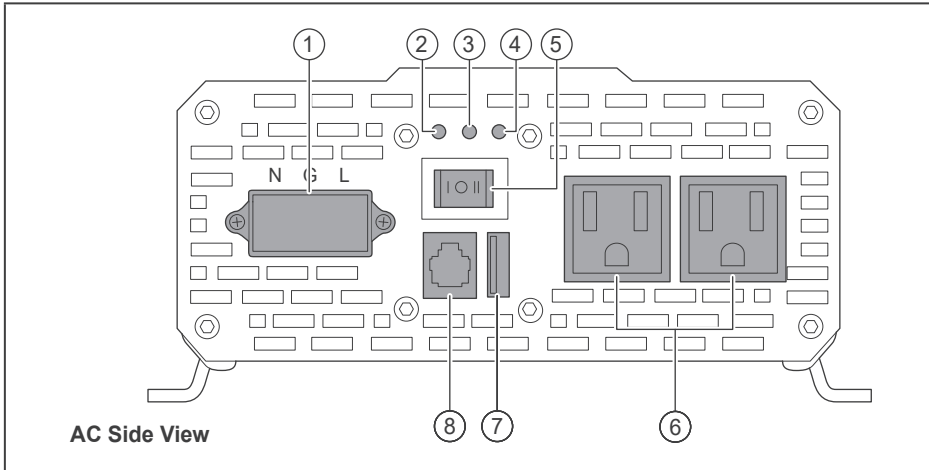

No.	Part	Description
1	High Output AC Terminals	<p>Connect to 115V AC devices operating at higher than 15 A or distributed wiring with multiple AC outlets.</p> <p>Remove the two screws on the protective cover to access the terminals.</p> <p>Terminal layout (facing the front panel)</p> <ul style="list-style-type: none"> • Left: Neutral (N) • Middle: Ground (G) • Right: Live (L) <p>Note that Neutral and Ground are bonded inside.</p>
2	Power LED (Green)	Indicates the operation status of the inverter.
3	GFCI LED (Yellow)	<p>Indicates that the ground fault circuit has been interrupted.</p> <p>In such case, restart the inverter.</p>
4	Fault LED (Red)	<p>Indicates that the inverter shuts down due to overheating, overload, undervoltage, or overvoltage.</p> <p>Solution: Immediately turn off all AC appliances. Allow the inverter to cool before continuing. Make sure that the ventilation vents are not blocked.</p> <p>If an inverter shutdown was preceded by a buzzing sound, there may be an excessive load in combination with low voltage or a cable problem.</p>

Product Overview

700W Inverter

1000W Inverter

2000W or 3000W Inverter

No.	Part	Description
5	ON/OFF/REM Switch	Turns inverter ON, OFF, or REMOTE.
6	AC Outlets	115V AC 60 Hz: <ul style="list-style-type: none"> • Up to 15 A for 2000W and 3000W models • Up to 8.7 A for 1000W models • Up to 6.1 A for 700W models
7	USB Power Port	Supplies 5V/2.1 A for charging tablets, smartphones, and other small appliances.
8	Remote Control Terminal	Connects to the Wired Remote Control.

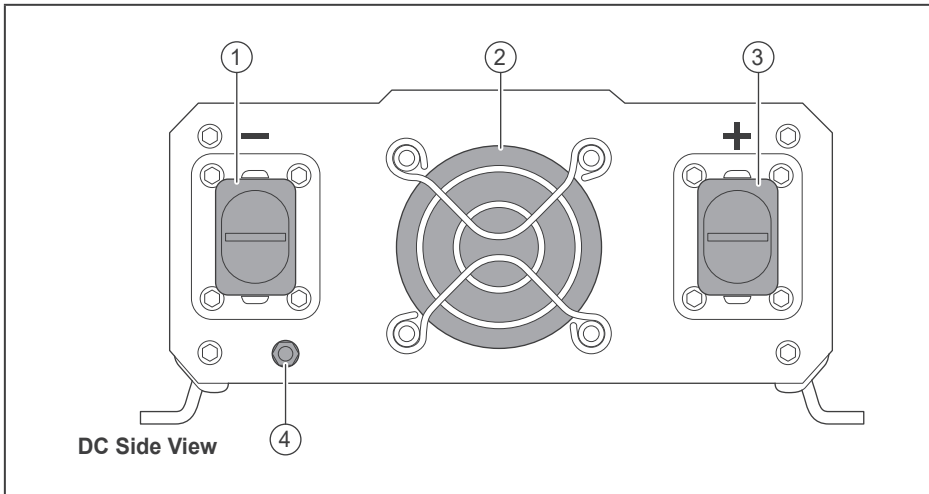

No.	Part	No.	Part
1	Negative (-) DC Input, M8	3	Positive (+) DC Input, M8
2	Cooling Fan	4	Ground, M4

Product Overview

700W Inverter

1000W Inverter

2000W or 3000W Inverter

2000W or 3000W Inverter

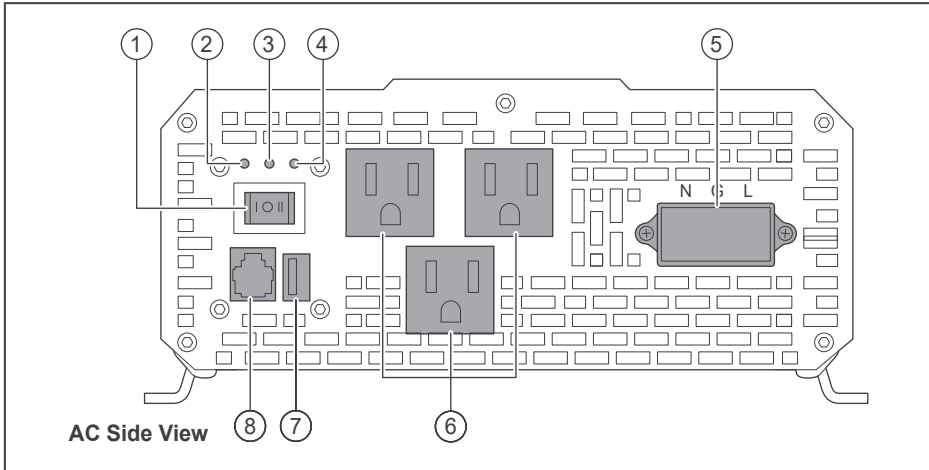

No.	Part	Description
1	ON/OFF/REM Switch	Turns inverter ON, OFF, or REMOTE.
2	Power LED (Green)	Indicates the operation status of the inverter.
3	GFCI LED (Yellow)	Indicates that the ground fault circuit has been interrupted. In such case, restart the inverter.
4	Fault LED (Red)	Indicates that the inverter shuts down due to overheating, overload, undervoltage, or overvoltage. Solution: Immediately turn off all AC appliances. Allow the inverter to cool before continuing. Make sure that the ventilation vents are not blocked. If an inverter shutdown was preceded by a buzzing sound, there may be an excessive load in combination with low voltage or a cable problem.

Product Overview

700W Inverter

1000W Inverter

2000W or 3000W Inverter

No.	Part	Description
5	High Output AC Terminals	<p>Connect to 115V AC devices operating at higher than 15 A or distributed wiring with multiple AC outlets.</p> <p>Remove the two screws on the protective cover to access the terminals.</p> <p>Terminal layout (facing the front panel)</p> <ul style="list-style-type: none"> • Left: Neutral (N) • Middle: Ground (G) • Right: Live (L) <p>Note that Neutral and Ground are bonded inside.</p>
6	AC Outlets	<p>115V AC 60 Hz:</p> <ul style="list-style-type: none"> • Up to 15 A for 2000W and 3000W models • Up to 8.7 A for 1000W models • Up to 6.1 A for 700W models
7	USB Power Port	Supplies 5V/2.1 A for charging tablets, smartphones, and other small appliances.
8	Remote Control Terminal	Connects to the Wired Remote Control.

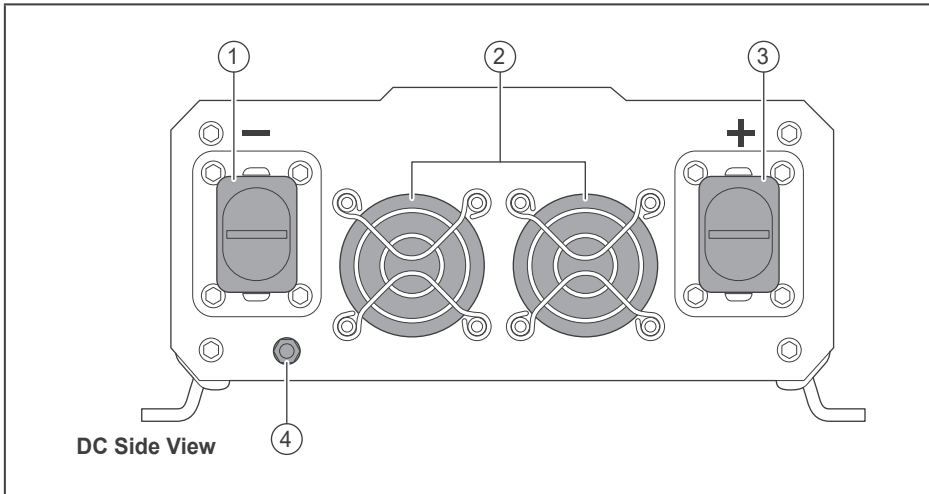

No.	Part	No.	Part
1	Negative (-) DC Input, M8	3	Positive (+) DC Input, M8
2	Cooling Fans	4	Ground, M4

Wiring Diagram

700W Inverter

1000W Inverter

2000W or 3000W Inverter

700W Inverter

■ AC Side View

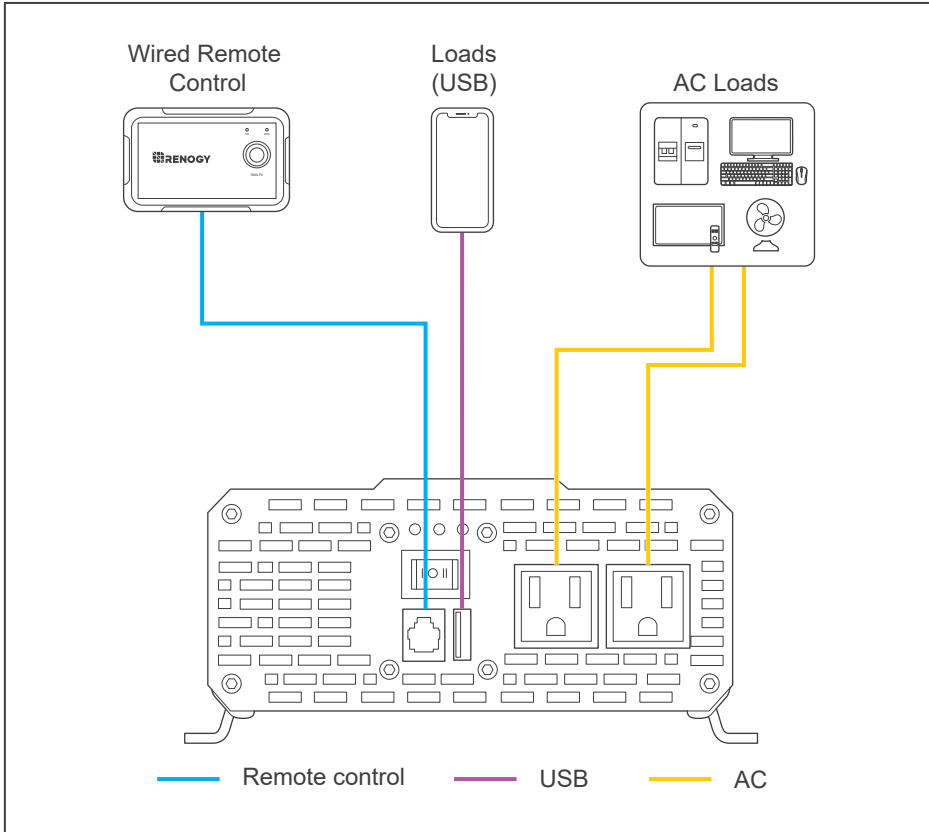

Wiring Diagram

700W Inverter

1000W Inverter

2000W or 3000W Inverter

■ DC Side View

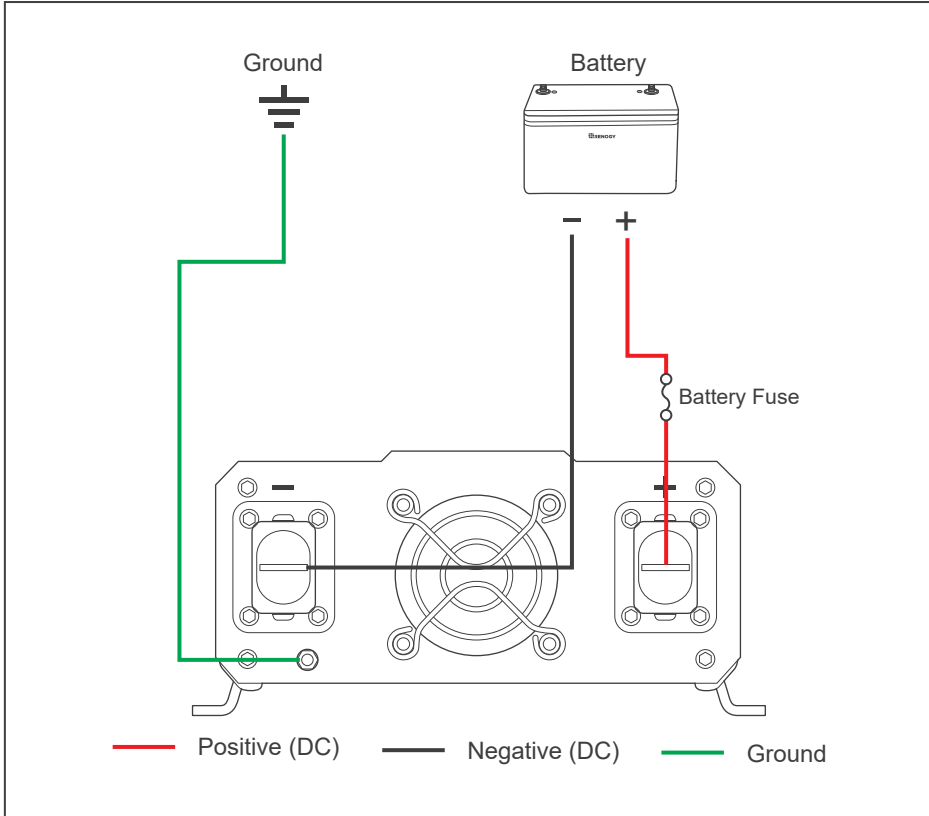

Wiring Diagram

700W Inverter

1000W Inverter

2000W or 3000W Inverter

1000W Inverter

■ AC Side View

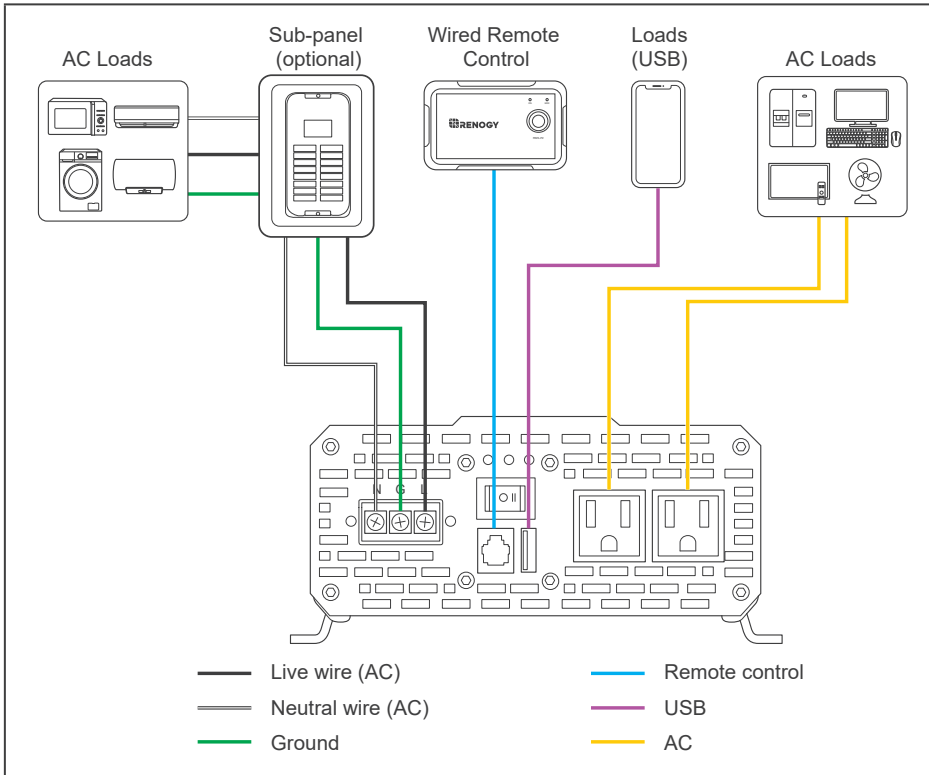

Wiring Diagram

700W Inverter

1000W Inverter

2000W or 3000W Inverter

■ DC Side View

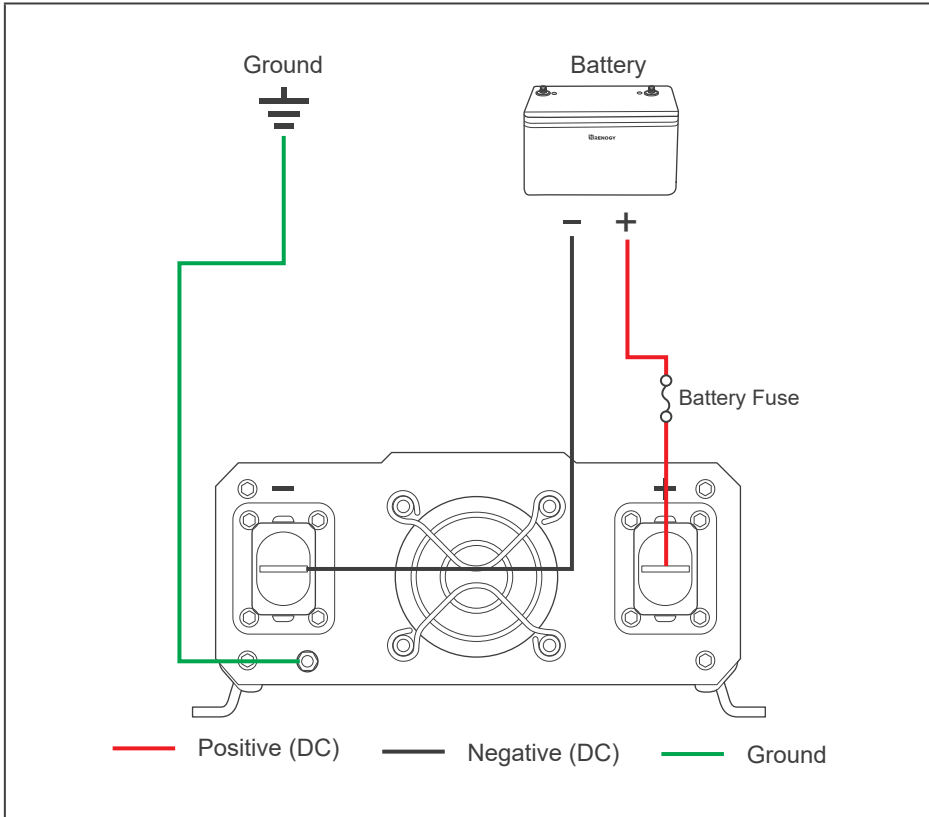

Wiring Diagram

700W Inverter

1000W Inverter

2000W or 3000W Inverter

2000W or 3000W Inverter

■ AC Side View

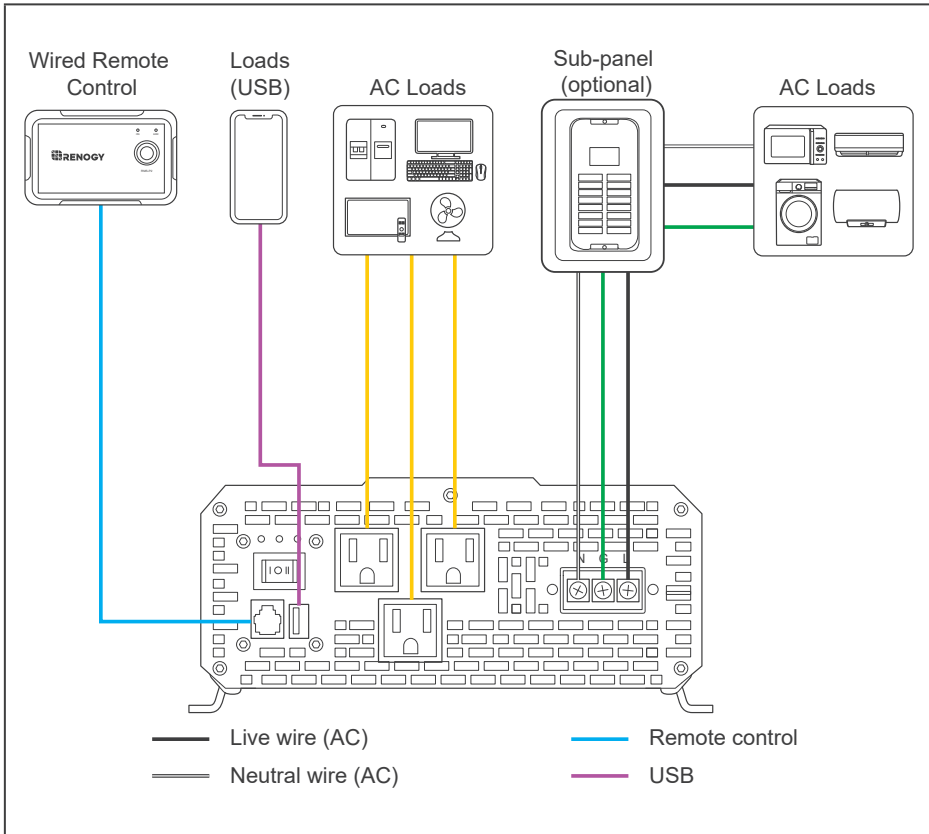

Wiring Diagram

700W Inverter

1000W Inverter

2000W or 3000W Inverter

■ DC Side View

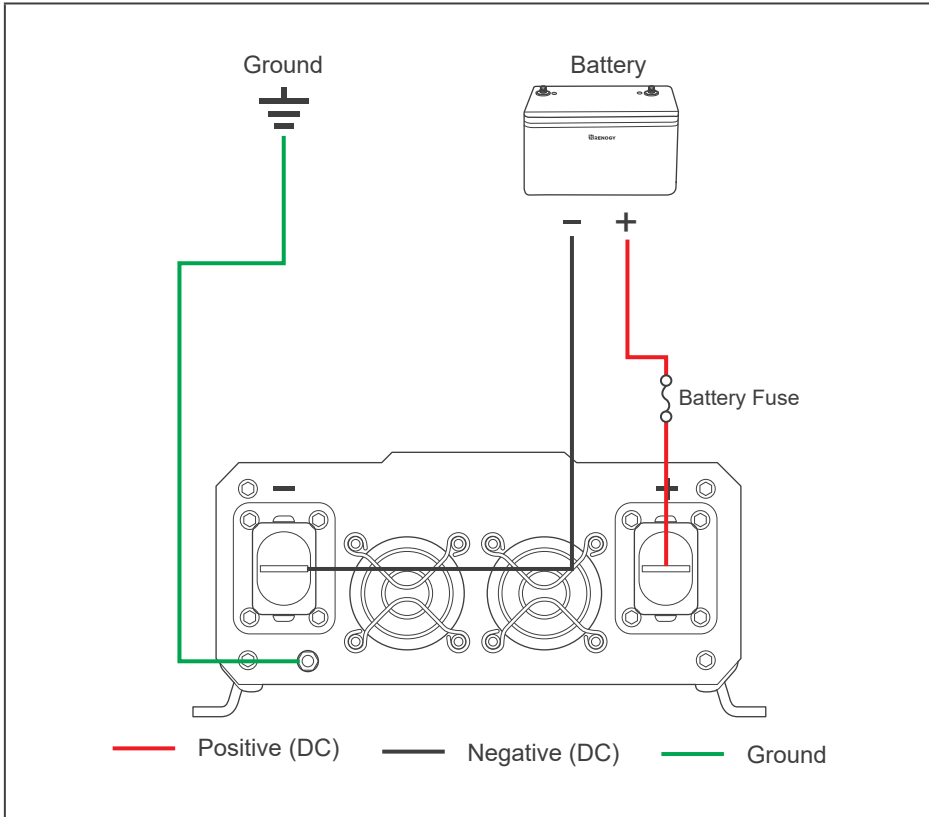

Installation

Plan an Installation Site

Size a Battery Bank

Ground

DC Wiring

AC Wiring



CAUTION

- Do not over-torque or overtighten the terminals. This could potentially damage the unit.
- Refer to the technical specifications for maximum wire sizes on the controller and for the maximum amperage going through wires.



WARNING

- Ensure the inverter is in the OFF position before connecting to anything.
- Do not install the inverter in the same compartment as the battery bank because it could serve as a potential fire hazard.
- Never mount the inverter vertically on a vertical surface since it would present a hazard for the fan opening, undermining cooling the inverter.

Plan an Installation Site

Follow the guidelines below:

- **Cool, dry, well-ventilated area**

The inverter must be installed in a site where the fans are not blocked or where they are not hit directly by the sun. The site should be free of any kind of moisture with a clearance of at least 10 inches around the inverter for adequate ventilation.

- **Protection against fire hazard**

The inverter should be away from any flammable material, liquids, or any other combustible material.

- **Close proximity to battery bank**

Put the inverter close to batteries banks to prevent excessive voltage drop. Choose a proper sized wire going from the battery bank to the inverter.

- **Limiting electromagnetic interference (EMI)**

Ensure the inverter is firmly grounded to a building or vehicle. Alternatively, it can be earth grounded. Keep the inverter away from EMI receptors such as TVs, radios, and other audio/visual electronics to prevent damage/interference.

- **Secure mounting**

The inverter should be stand-alon or mounted by using the outlying terminals with M3 and M6 screws on the inverter.

Installation

Plan an Installation Site

Size a Battery Bank

Ground

DC Wiring

AC Wiring

Size a Battery Bank

Battery types and capacity relate to the overall inverter performance. To size a proper battery bank, you need to identify the loads that you will be utilizing, as well as an estimate duration (hours/day) you will be using the load. The inverter is only compatible with 12V battery banks and oversizing should be considered due to efficiency losses.

1. Determine Your Watts (Amps x Volts)

Every electronic will have a sticker or plate identifying the watts directly (W) or will show you the voltage value (V) as well as amperage (A) which need to be multiplied to get Watts. The formula is below:

$$\text{Watts (W)} = \text{Volts (V)} \times \text{Amps (A)}$$

$$\text{Example: Fan Watts} = 120\text{V} \times 0.4\text{A} = 48\text{Watts}$$

2. Estimate Load Run-Time in Watt-Hours (Wh)

Estimate how many hours per day you will be using the load and multiply this by your Watts per load.

$$\text{Example: Fan Watts} \times 12 \text{ hours} = \text{Watt-Hour (Wh)}$$

$$46\text{W} \times 12\text{h} = 576\text{Wh}$$

3. Determine Battery Capacity in Amp-Hour (Ah)

Divide your Load Run Watt-Hour result by the battery voltage.

$$\text{Load Run-Time (Wh)/Battery Voltage (V)} = \text{Amp-Hour (Ah)}$$

Use 12V, supported voltage of the inverter as a reference.

$$576\text{Wh}/12\text{V} = 48 \text{ Ah}$$

4. Oversize the Battery

The calculated Amp-Hour value represents the minimum size battery capacity to run your load for your intended time. Note that this assumes 100% use of a battery, which is not recommended. Assuming 50% depth of discharge, you want to multiply this value by 2 and you also want to multiply by 1.25 to account for some efficiency losses.

Formula:

$$48\text{Ah} \times \text{Oversize} \times \text{Efficiency Losses} = \text{Recommended Amp-Hour}$$

$$48 \times 2 \times 1.25 \approx 115\text{Ah}$$

Therefore, a 115Ah battery bank, or close, will be able to support a 12-hour run time while also prolonging battery life for the best system size possible.

NOTE

- You will need a battery charging source as this is a non-charging inverter and will only work to deplete the battery.
- Actual battery quantities vary by battery capacity and rates of discharge.

Installation

Plan an Installation Site

Size a Battery Bank

Ground

DC Wiring

AC Wiring

Ground

If available, the chassis ground lug should be connected to a ground point such as a vehicle chassis or boat grounding system. In fixed locations, connect the ground lug to earth ground. The connections to ground must be tight and against bare metal. Grounding is highly recommended for both when using the inverter in a mobile application, such as an RV, or in a building.

Recommended wire material: insulated copper strand wire

Recommended wire size:

- 14AWG to 18AWG (700W)
- 14AWG (1000W)
- 12AWG (2000W)
- 10AWG (3000W)

DC Wiring



CAUTION

- Be careful of the positive and negative poles. Reversing the poles might cause permanent damage to the inverter and will void the warranty.



WARNING

- The inverter is suitable for 12V battery bank systems ONLY. Not following the minimum DC requirement will cause irreversible damage to the device.



NOTE

- The input terminals of the inverters are embedded with large capacitors. The input circuit is completed once the terminals are connected to both positive and negative wires. This commences drawing a heavy current momentarily. As a result, there may be a sparking occurring even if the inverter is in the off position. To minimize sparking, it is recommended that you should choose an appropriate sized wire feeding into the inverters and/or install an external fuse leading into the inverter.

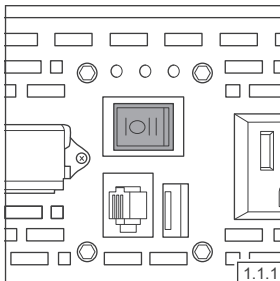

1. On the AC side, set the ON/OFF Switch to the OFF position.

Installation

Plan an Installation Site

Size a Battery Bank

Ground

DC Wiring

AC Wiring

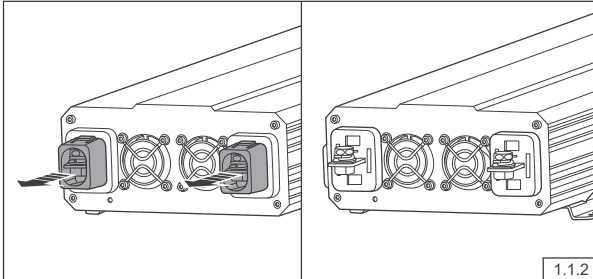

1.1.2

2. On the DC side, remove the protection cap.

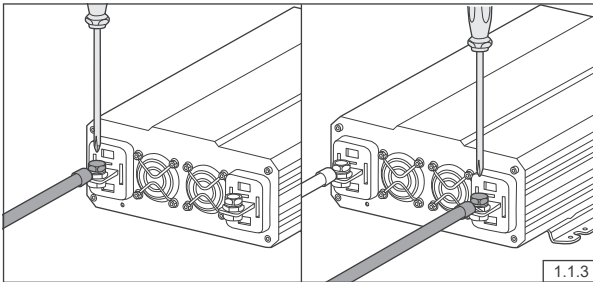

1.1.3

3. Unscrew Positive and Negative DC Input Terminals, connect a battery bank to the terminals, and tight the terminal screws.

Torque: 14(±0.5) N·m

For your safety, it is recommended to use a battery fuse.

Model	RNG-INVT-700-12V-P2	RNG-INVT-1000-12V-P2	RNG-INVT-2000-12V-P2	RNG-INVT-3000-12V-P2
Continuous Output Power	700W	1000W	2000W	3000W
Battery Fuse	100A	150A	250A	400A

Installation

Plan an Installation Site

Size a Battery Bank

Ground

DC Wiring

AC Wiring

AC Wiring

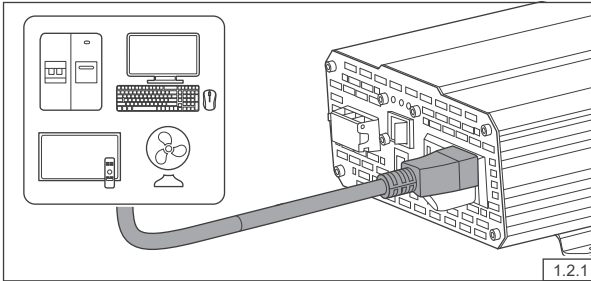

You can plug your AC loads directly into the receptacles on the inverter's AC side.

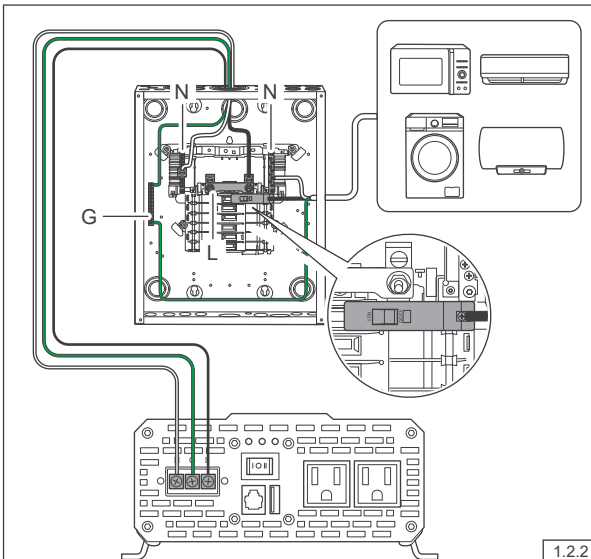

You can also permanently connect the AC output from the AC hardwire terminal through the AC knockout into a load sub-panel or additional AC outlets powered by the 1000W/2000W/3000W inverter. From left to right, the terminal block indicates: Live/Hot (L), Neutral (N), and Ground (G).

■ Recommended Ground-Fault Circuit Interrupter (GFCI)

A ground-fault circuit interrupter, or GFCI, is a device that help protect people from electric shocks by de-energizing a circuit or portion of a circuit within an established period of time when a current to ground exceeds some predetermined value that is less than that required to operate the overcurrent device (circuit breaker or fuse) of the supply circuit. GFCIs are usually required in wet or damp locations.

While the inverter is equipped with a GFCI, it is recommended to install an external GFCI where you can manually test the circuit.

The following table lists GFCIs that meet the specifications and will function properly when they are connected to the AC Outlets of the inverter.

Installation

Plan an Installation Site

Size a Battery Bank

Ground

DC Wiring

AC Wiring

Tested GFCI Models	
Manufacturer	Model Number
Leviton	GFNT2
Hubbell	GFP1305
Hubbell	GF15WLA

WARNING

- Risk of electrical shock. Use only ground-fault circuit interrupters [receptacle(s) or circuit breaker(s)] compatible with your inverter.

CAUTION

- GFCIs shall be installed in a recreational vehicle's wiring system to protect all branch circuits.

Operation

Operations on Inverter

Wired Remote Control

Operations on Inverter

After proper battery and AC load connections, you can operate the inverter.

1. On the AC side, rock the ON/OFF Switch to the ON position.
2. The inverter is operating normally.
3. When finishing using the inverter, power off the AC loads first, and then rock the ON/OFF Switch to the OFF position.



CAUTION

- When the inverter turns on, it is normal to hear the fans run for a second and hear a beep.
- Avoid powering on the inverter with the load (electronic devices) already switched on. This may trigger an overload since some electronic devices have an initial high power surge to start.
- When switching off the inverter, turn off the electronic devices first. Although the inverter is off, the terminal capacitors will still have a charge, so the DC and AC terminals must be disconnected if altering the circuitry.

Wired Remote Control

The Wired Remote Control gives you the opportunity to power on/off the inverter from a distance (approximately 16.4 ft / 30.5 mm).

Note that the inverter ON/OFF switch should be in the REM position.

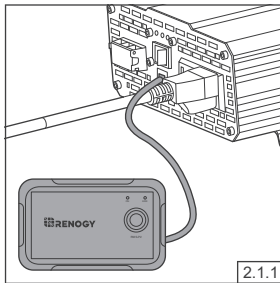



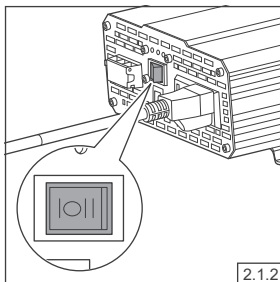





1. Connect the Wired Remote Control to the inverter via the Remote Control Connector.





2. Rock the ON/OFF Switch to the REM position, and you can power on/off the inverter via the Wired Remote Control.

LED Overview

LED Status	Alarm	Protection & Alarm	Inverter Status
Fault LED in solid red  	Long steady beeping sound	Overtemperature protection	No output from the inverter.
		Undervoltage shutdown	No output from the inverter.
		Overload protection	No output from the inverter output side. After 5s, the inverter automatically restarts. After five times of failed restart, the inverter needs to be restored by manually turning it on.
Fault LED off  	No sound	Short circuit protection	No output from the inverter output side. After 5s, the inverter automatically restarts. After five times of failed restart, the inverter needs to be restored by manually turning it on.
Power LED in solid green and fault LED off  	Beeping sound	Undervoltage alarm	Constant output from the inverter.
Power LED in solid green  	No sound	Recovery from undervoltage	Normal output from the inverter output side.
GFCI LED in solid yellow GF 	No sound	GFCI protection	<ol style="list-style-type: none"> No output from the inverter output side. Please disconnect appliances and turn off the ON/OFF switch to reset, then try to connect different appliances separately and see if the yellow LED of the inverter is always on. If not, it indicates a current leakage problem on the appliance. If it's always on, please contact Renogy to deal with it.

Troubleshooting

Indicator & Alarm	Potential Issue	Solution
Alarm beeps	Input voltage is below 11V.	Keep input voltage above 11V.
	Input voltage is above 16.0V.	Keep input voltage below 16.0V.
Fault LED lit, long beeping alarm sound, and inverter shutdown  	Input voltage is below 10V.	Keep input voltage above 10V.
	Input voltage is above 16.5V.	Keep input voltage below 16.5V.
	Inverter overheats	Allow inverter to cool down.
		Check for adequate ventilation.
		Reduce the load on the inverter.
	Operating equipment draws too much power	Use a higher wattage inverter or use a lower powered device.
Inverter is short circuited	Disconnect the inverter and turn off the ON/OFF Switch to reset.	
Yellow LED lit and Inverter shut down GF 	GFCI tripped	Disconnect appliances and turn off the ON/OFF Switch to reset.

Dimensions

700W Inverter

1000W Inverter

2000W Inverter

3000W Inverter



CAUTION

- Dimension tolerance: ± 0.2 in (0.5 mm)

700W Inverter

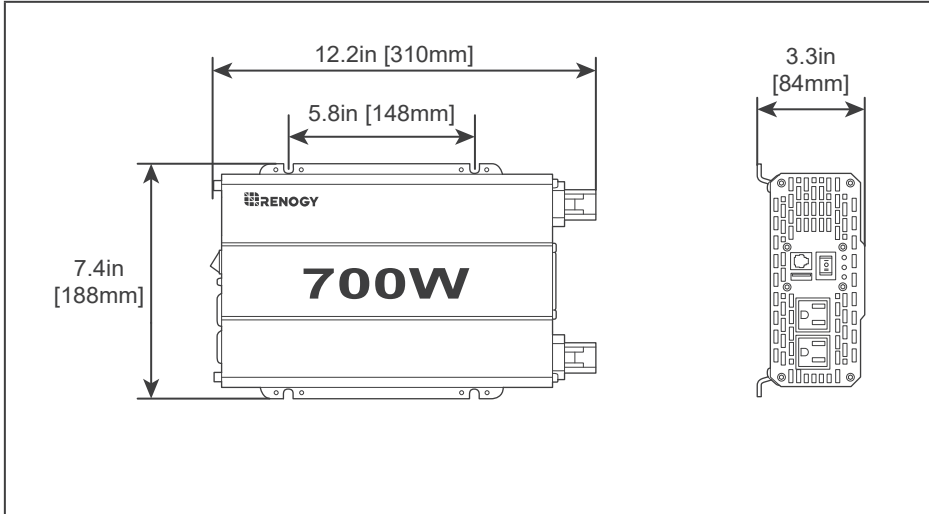

1000W Inverter

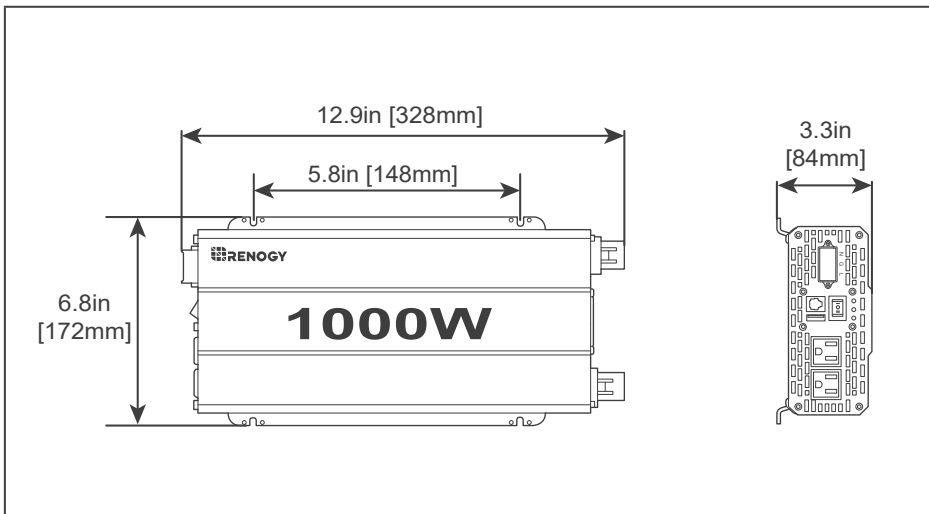

Dimensions

700W Inverter

1000W Inverter

2000W Inverter

3000W Inverter

2000W Inverter

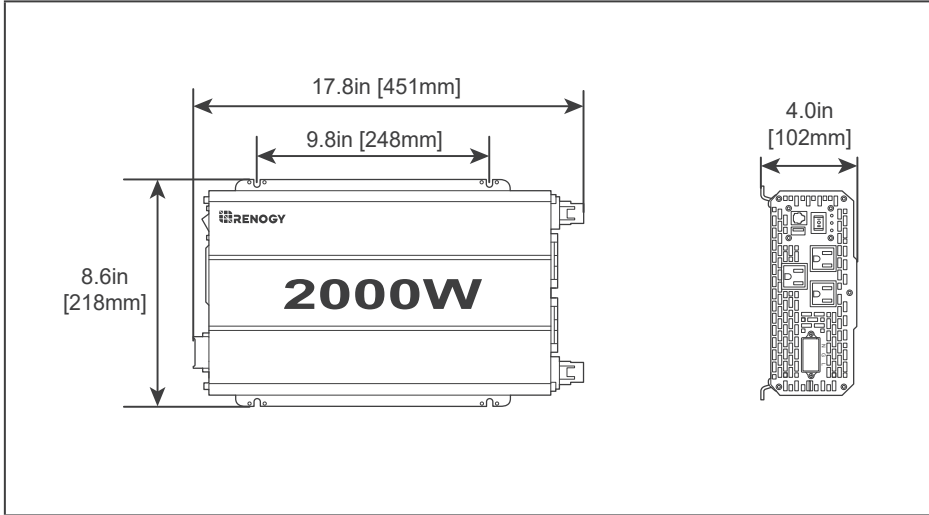

3000W Inverter

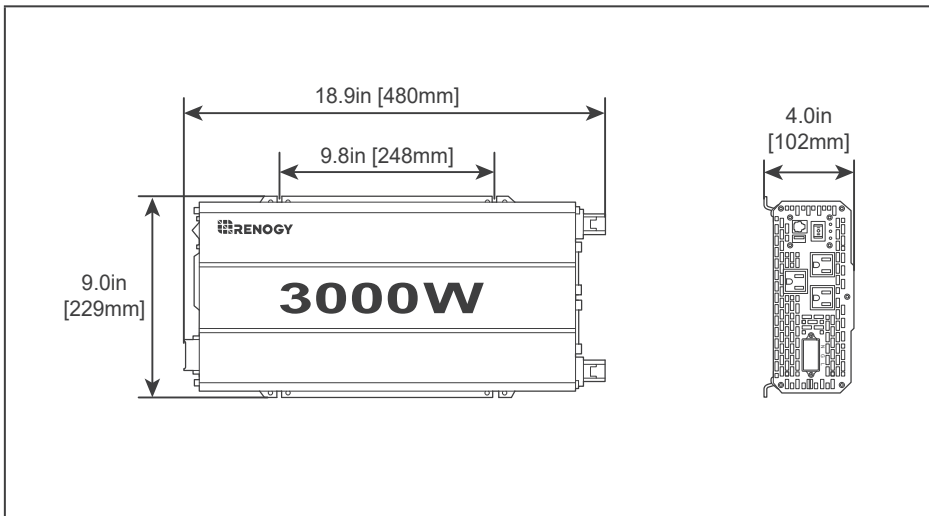

Specifications

General Data

Electrical Data

Wired Remote Data

General Data

Model	RNG-INVT-700-12V-P2	RNG-INVT-1000-12V-P2	RNG-INVT-2000-12V-P2	RNG-INVT-3000-12V-P2
Output Waveform	Pure Sine Wave			
AC Terminals	2 x AC Sockets	2 x AC Sockets + Terminal Block	3 x AC Sockets + Terminal Block	
DC Terminals	M8 - 1.25 x 15 mm			
Operating Temperature	-4°F to 104°F / -20°C to 40°C			
Storage Temperature	-40°F to 158°F / -40°C to 70°C			
Humidity	Max 93%, non-condensing			
Cooling	Thermally Controlled Fans			
Dimensions (L x W x H)	12.2 x 7.4 x 3.3 in / 310 x 188 x 84 mm	12.9 x 6.8 x 3.3 in / 328 x 173 x 84 mm	17.8 x 8.6 x 4 in / 452 x 218 x 102 mm	18.9 x 9 x 4 in / 480 x 229 x 102 mm
Weight	5.6 lb	6.0 lb	11.7 lb	12.5 lb
Regulatory and Safety Specifications	UL certified to 458 and to CSA 22.2 No. 107.1-01			

Electrical Data

Model	RNG-INVT-700-12V-P2	RNG-INVT-1000-12V-P2	RNG-INVT-2000-12V-P2	RNG-INVT-3000-12V-P2
Continuous Output Power	700W	1000W	2000W	3000W
Continuous Output Current	5.8A AC	8.3A AC	16.6A AC	25A AC
Total Harmonic Distortion (THD)	<3%			
Power Factor	0.9 to 1			
Surge Rating	1400W (@ 1s)	2000W (@ 1s)	4000W (@ 1s)	6000W (@ 1s)
Output Voltage	115V AC			
Output Frequency	60Hz			
Rated Battery Input Voltage	12V DC			

Specifications

General Data

Electrical Data

Wired Remote Data

Battery Input Voltage Range	10V to 16V DC			
Maximum Continuous Battery Output Current	58.3A	83.3A	166.6A	250A
Inverter Efficiency	>90%			
Full Load Efficiency	>85%			
Power Consumption	<10W	<12W	<24W	<30W
Battery Overvoltage Shutdown	16.5V ($\pm 0.3V$) DC			
Battery Low Voltage Alarm	11V ($\pm 0.3V$) DC			
Battery Low Voltage Shutdown	10.5V ($\pm 0.3V$) DC			

Wired Remote Data

Front Plate Dimensions	3.6 x 2.02 x 1.4 in / 92.2 x 51.2 x 35.56 mm
Wired Length	16.4 ft

Technical Support

For additional support, contact the Renogy technical support team through [renogy.com/contact-us](https://www.renogy.com/contact-us). Have the following information available when contacting Renogy.

- Owner name
- Contact information
- Order number
- Purchase channel
- Serial number
- Brief description of the issue

 **Renogy offers premium services worldwide:**

North America	US	www.renogy.com	CA	ca.renogy.com
	AU	au.renogy.com	CN	www.renogy.cn
Asia/Pacific	JP	renogy.jp	KR	kr.renogy.com
	UK	uk.renogy.com	DE	de.renogy.com
Europe	FR	fr.renogy.com	ES	es.renogy.com

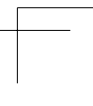
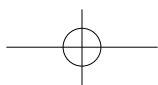
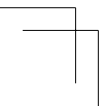
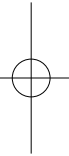
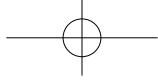
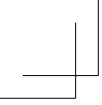



Renogy Empowered

Renogy aims to empower people around the world through education and distribution of DIY-friendly renewable energy solutions.

We intend to be a driving force for sustainable living and energy independence.

In support of this effort, our range of solar products makes it possible for you to minimize your carbon footprint by reducing the need for grid power.



Live Sustainably with Renogy

Did you know? In a given month, a 1KW solar energy system will...



Save 170 pounds of coal from being burned



Save 300 pounds of CO₂ from being released into the atmosphere



Save 105 gallons of water from being consumed



Renogy Power **PLUS**

Renogy Power Plus allows you to stay in the loop with upcoming solar energy innovations, share your experiences with your solar energy journey, and connect with like-minded people who are changing the world in the Renogy Power Plus community.



Join the Renogy Power Plus Community
by downloading the DC Home App.
Find your e-warranty here, and more.

