



# Table of Contents

1. Important Safety Information .....	- 3 -
1.1 General Safety Precautions .....	- 3 -
1.2 Precautions When Working with Batteries .....	- 3 -
2 Introduction .....	- 4 -
2.1 General Information .....	- 4 -
2.2 Application .....	- 4 -
2.3 Mechanical Drawing .....	- 5 -
2.4 Features .....	- 7 -
2.5 Electrical Performance .....	- 8 -
2.5.1 Invert .....	- 8 -
2.5.2 AC Charger .....	- 9 -
2.5.3 Transfer .....	- 11 -
2.5.4 Power Saver .....	- 12 -
2.5.5 Protections .....	- 13 -
2.5.6 Remote Control .....	- 14 -
2.5.7 LED Indicator .....	- 15 -
2.5.8 Audible Alarm .....	- 15 -
2.5.9 FAN Operation .....	- 16 -
2.5.10 DIP Switches .....	- 16 -
2.5.11 Auto Generator Start .....	- 18 -
2.5.12 Battery Temperature Sensing .....	- 18 -
2.5.13 Other Features .....	- 19 -
3 Installation .....	- 19 -
3.1 Unpacking and Inspection .....	- 19 -
3.2 Installation Location, Tools & Materials .....	- 19 -
3.3 DC Wiring .....	- 20 -
3.4 AC Wiring .....	- 22 -
3.5 Grounding .....	- 23 -
3.6 Mounting the Inverter .....	- 25 -
4 Troubleshooting Guide .....	- 27 -
5 Limited Warranty .....	- 30 -
Appendix 1 - PICOGLF Series Spec Sheet .....	- 32 -
Appendix 2 - Circuit Schematics .....	- 34 -
Appendix 3 - Installation Diagram .....	- 37 -
Appendix 4 - Inverter Efficiency .....	- 38 -

**Please record the unit's model and serial number in case you need to provide this information in the future. It is much easier to record this information now than try to gather it after the unit has been installed.**

**Model Number:** \_\_\_\_\_

**Serial Number:** \_\_\_\_\_

# 1. Important Safety Information

**Read this manual before installation, as it contains important safety, installation and operating instructions. Keep it in a safe place for future reference.**

**All wiring must follow the National Electric Code, Provincial or other codes in effect at the time of installation, regardless of suggestions in this manual. All wires should be copper conductors.**

## 1.1 General Safety Precautions

1-1-1. Do not expose the inverter to rain, snow, spray, bilge or dust. To reduce risk of hazard, do not cover or obstruct the ventilation openings. Do not install the inverter in a zero-clearance compartment. Overheating may result. Allow at least 12" of clearance around the inverter for air flow. Make sure that the air can circulate freely around the unit. A minimum air flow of 145CFM is required.

1-1-2. To avoid risk of fire and electronic shock, make sure that existing wiring is in good electrical condition and that the wire is not undersized. Do not operate the inverter with damaged or substandard wiring.

1-1-3. This equipment contains components which may produce arcs and/or sparks. To prevent fire and/or explosion do not install in compartments containing batteries or flammable materials or in a location that requires ignition protected equipment. This includes any space containing gasoline-powered machinery, fuel tanks, joints, fittings, or other connection between components of the fuel system. See Warranty for instructions on obtaining service.

1-1-4. Do not disassemble the inverter. It contains no user-serviceable parts. Attempting to service the inverter yourself may result in electrical shock or fire. Internal capacitors remain charged after all power is disconnected.

1-1-5. To reduce the risk of electrical shock, disconnect both AC and DC power from the inverter before attempting any maintenance or cleaning. Turning off controls will not reduce this risk.

### **CAUTION: Equipment damage**

The output side of the inverter's AC wiring should at no time be connected to public power or a generator. This condition is far worse than a short circuit. If the unit survives this condition, it will shut down until corrections are made.

Installer should ensure that the inverter's AC output is, at no time, connected to its AC input.

### **WARNING: LIMITATIONS OF USE**

SPECIFICALLY, PLEASE NOTE THAT THE INVERTER/CHARGER SHOULD NOT BE USED IN CONNECTION WITH LIFE SUPPORT SYSTEMS OR OTHER MEDICAL EQUIPMENT OR DEVICES. WE MAKE NO WARRANTY OR REPRESENTATION IN CONNECTION WITH THEIR PRODUCTS FOR SUCH USES. USING THE INVERTER/CHARGER WITH THIS PARTICULAR EQUIPMENT IS AT YOUR OWN RISK.

## 1.2 Precautions When Working with Batteries

1-2-1. If battery acid contacts skin or clothing immediately wash with soap and water. If acid enters eyes immediately rinse eyes with running cold water and seek immediate medical attention.

1-2-2. Never smoke or allow a sparks or flames in the vicinity of a battery.

1-2-3. Do not drop a metal tool on the battery. The resulting spark or short-circuit on the battery can cause an explosion.

1-2-4. Remove personal metal items such as rings, bracelets, necklaces, and watches when working with a battery. A battery produces a short-circuit current high enough to weld any metal objects and will cause a severe burn.

1-2-5. To reduce the risk of injury, charge only deep-cycle lead acid, lead antimony, lead calcium gel cell, absorbed mat, or NiCad/NiFe, lithium type rechargeable batteries. Other types of batteries may swell or burst causing personal injury and damage.

## **2 Introduction**

### **2.1 General Information**

The AIMS Power 3000 watt 50 amp bypass pure sine wave inverter is an inverter, battery charger and AC auto-transfer switch into one device with a peak conversion efficiency of 88%.

It is packed with unique features and it is one of the most advanced inverter chargers on the market today. It features power factor correction, sophisticated multi-stage charging and pure sine wave output with unprecedentedly high surge capability to meet demanding power needs of inductive loads without damaging the equipment.

When utility AC power cuts off (or falls out of acceptable range), the transfer relay is de-energized and the load is automatically transferred to inverter mode. Once the qualified AC power is restored the relay is re-energized and the load is automatically reconnected to AC bypass mode. The Global LF Series inverter is equipped with a powerful smart charger. The overload capacity is 300% of continuous output for up to 20 seconds to reliably support tools and equipment.

The inverter can also be set to Battery Priority via a DIP switch. This helps to extract maximum power from the battery in renewable energy systems such as solar and wind. The Global LF Series Pure Sine Wave inverter is suitable for Renewable energy systems in work trucks, RV, Marine and Emergency appliances.

To get the most out of the power inverter, it must be operated and maintained properly. Please read the instructions in this manual before installing and operating

### **2.2 Application**

Power tools—circular saws, drills, grinders, sanders, buffers, weed and hedge trimmers, air compressors.

Office equipment – computers, printers, monitors, facsimile machines, scanners.

Household items – vacuum cleaners, fans, fluorescent and incandescent lights, shavers, sewing machines.

Kitchen appliances – coffee makers, blenders, ice makers, toasters.

Industrial equipment – metal halide lamp, high – pressure sodium lamp.

Home entertainment electronics – televisions, DVRs, video games, stereos, musical instruments, satellite equipment.

*And much more...*



## 2.3 Mechanical Drawing

### DC Side (Figure 1)

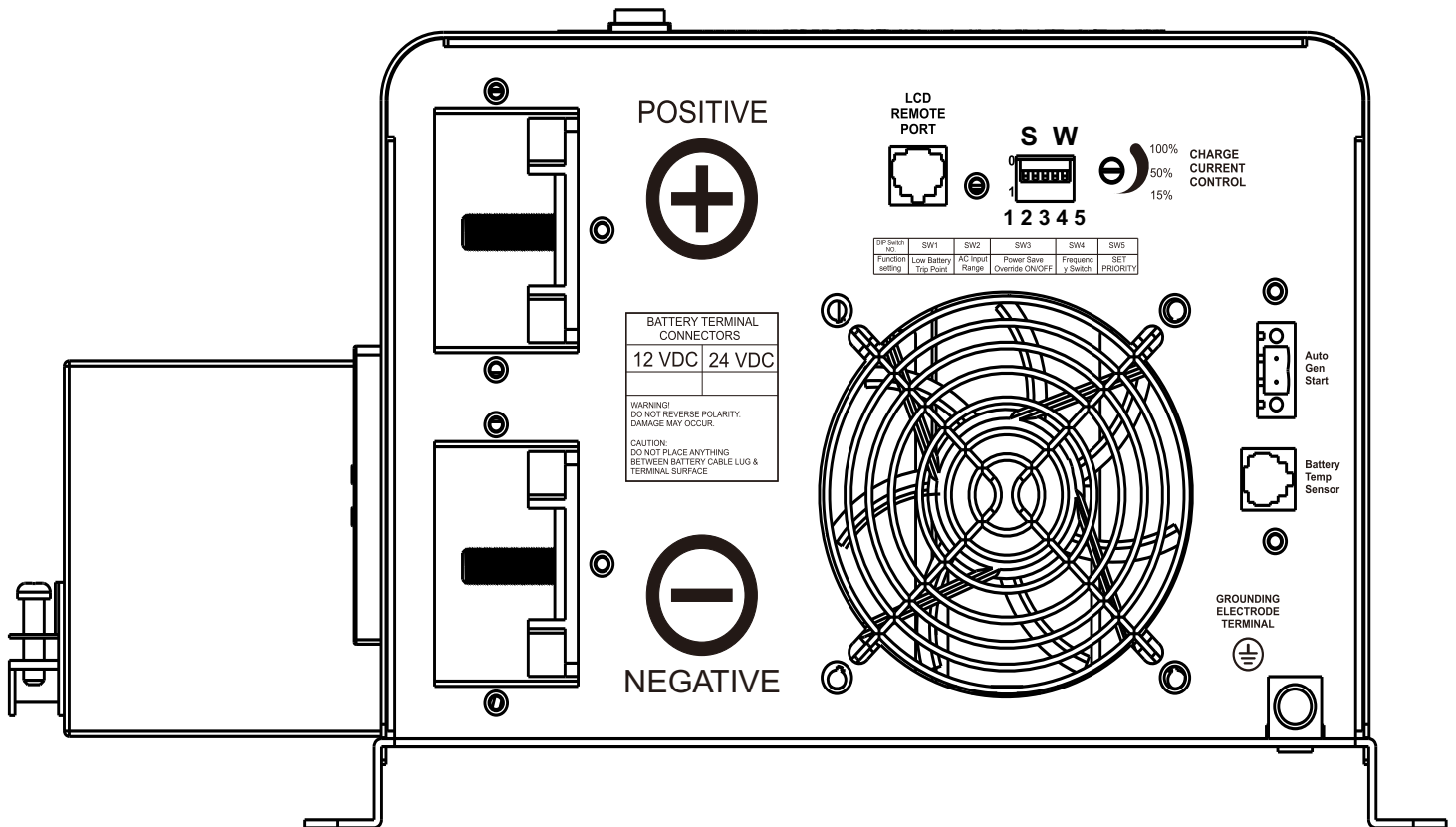

Figure 1

### AC Side (Figure 2)

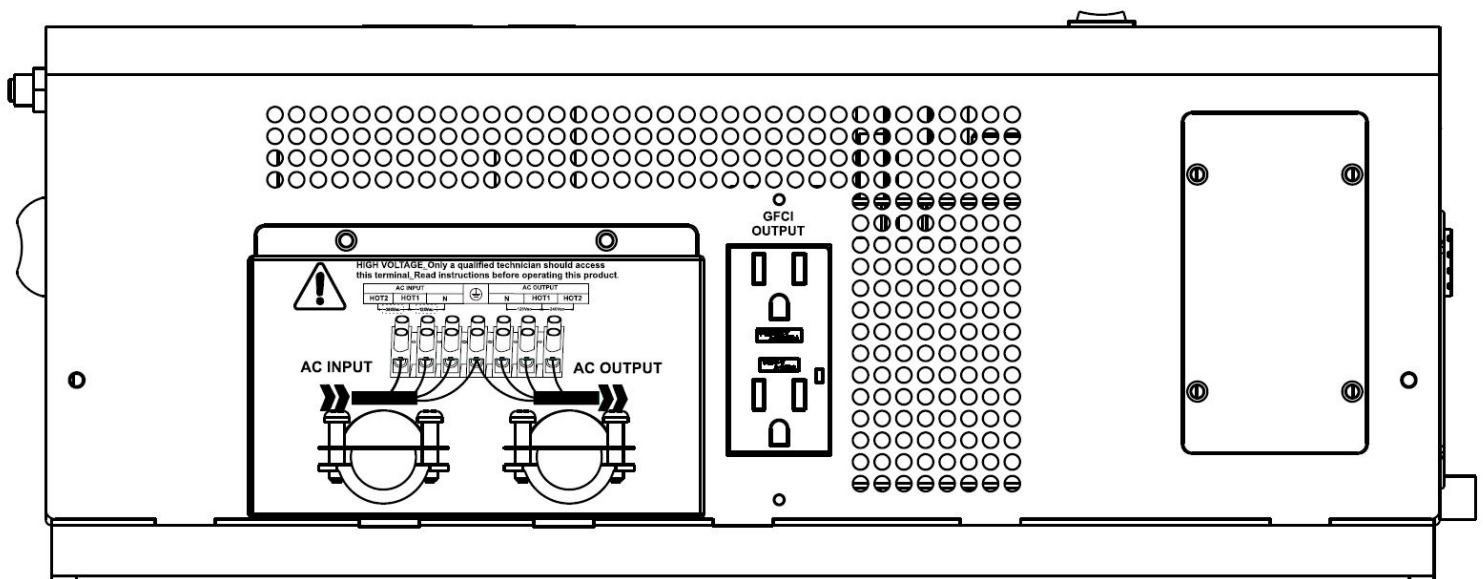

Figure 2

## Breaker Side (Figure 3)

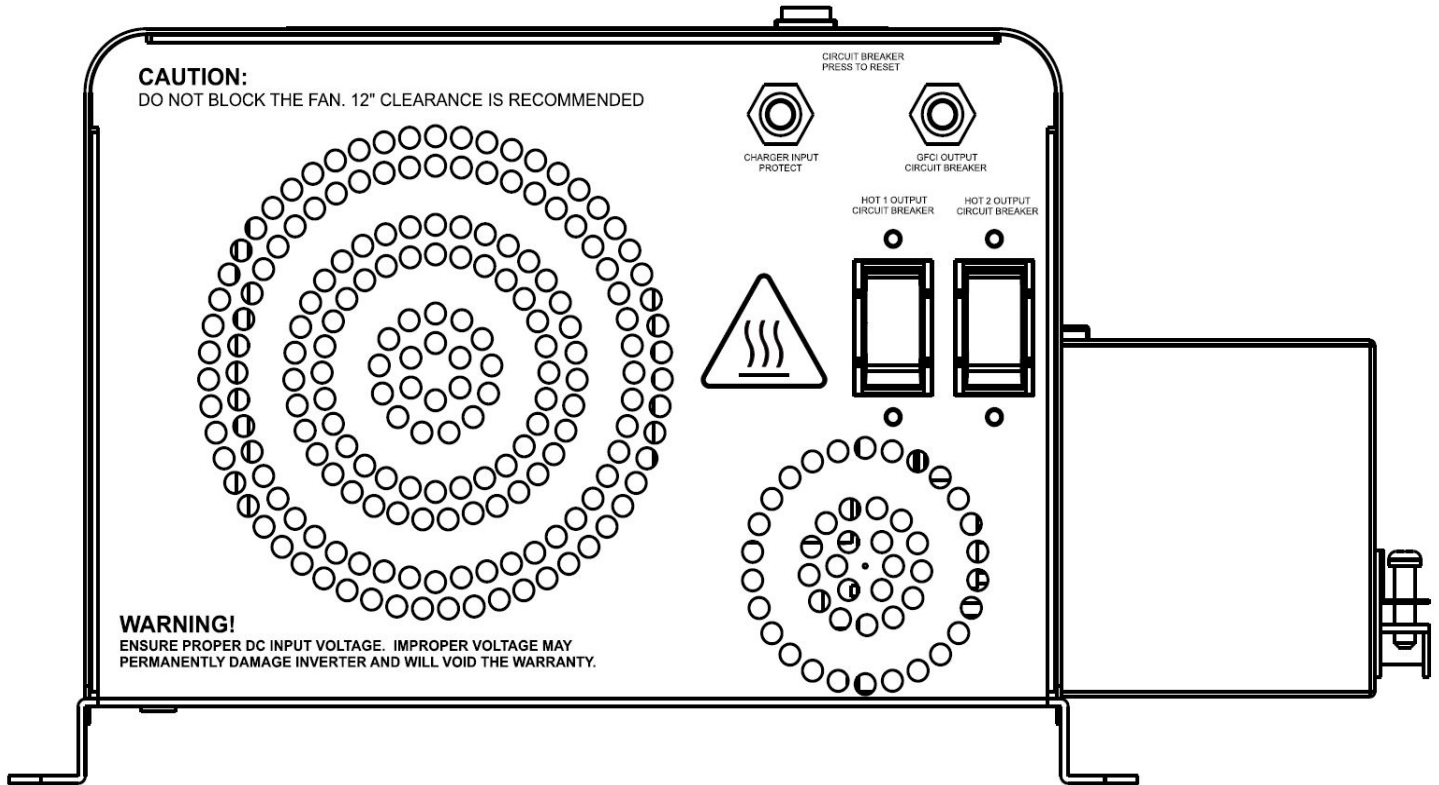

Figure 3

## 2.4 Features

- High surge ability up to 300% of rated power (20 sec)
- Powerful 100 amp battery charger for lead, gel, AGM, NiCAD/NiFe, and lithium
- Bypasses 30A 120Vac and 50A 240Vac
- Low quiescent current, low power “Power Saving Mode” to conserve energy
- Automatic Generator Start
- Battery temperature sensing for increased charging precision
- 3-step intelligent battery charger, PFC (Power Factor Correction)
- 8 pre-set battery type selector switch plus de-sulphation for totally flat batteries
- Powerful charge rate of up to 100Amps, selectable from 15%-100%
- 10 ms typical transfer time between battery and AC, guarantees power continuity
- Optional LCD remote control panel (Part # REMOTELF)
- Automatic ground & neutral bonding with manual disability
- 15s delay before transfer when AC resumes, extra protection for loads when used with generator
- Allows start up and through power with depleted batteries
- Multiple cooling fans
- Extensive protections against various harsh situations
- 13VDC battery recovery point, dedicated for renewable energy systems

## 2.5 Electrical Performance

### 2.5.1 Invert

#### Topology

The Global LF inverter is built according to the following topology.

Invert: Full Bridge Topology.

Charge: Isolated Boost Topology.

It works bi-directionally: in one direction it converts DC power from the battery to AC power (inverter Mode) and in the other direction it converts external AC power to DC power to charge the batteries (AC Mode). The same power components are used in both directions, resulting in high-energy transfer efficiency with fewer components. When operating in invert mode, the direct current (DC) that enters the inverter from the batteries is filtered by a large input capacitor and switched “On” and “Off” by the Metal Oxide Silicon Field Effect Transistors (MOSFET) at a rate of 50 Hz or 60Hz, in this step the DC is converted to low voltage synthesized sine wave AC using an H-bridge configuration and high frequency PWM (Pulse Width Modulation) technique. It is then directed into the transformer which steps the low AC voltage up to 230 or 120 volts. The unit has a 16bit, 4.9MHZ microprocessor to control the output voltage and frequency as the DC input voltage and/or output load varies.

Because of high efficiency MOSFETs and the heavy transformers, it outputs PURE SINE WAVE AC with an average THD of 10% (min 3%, max 20% under full linear loads) depending on load connected and battery voltage.

The peak DC to AC conversion efficiency of the Global LF series is 92%.



**Don't parallel the AC output of the inverters to increase power capacity as they have no stacking functionality.**

#### Overload Capacity

The Global LF series inverters have high overload capacities, making it ideal to handle demanding loads.

1. For  $110\% < \text{Load} < 125\% (\pm 10\%)$ , no audible alarm for 14 minutes, beeps 0.5s every 1s in the 15th minute, and Fault (Turn off) after the 15th minute.
2. For  $125\% < \text{Load} < 150\% (\pm 10\%)$ , beeps 0.5s every 1s and Fault (Turn off) after 1 minute.
3. For  $300\% \cong \text{Load} > 150\% (\pm 10\%)$ , beeps 0.5s every 1s and Fault (Turn off) after 20s.

#### Caution:

After the inverter is switched on, it takes a set time for it to self diagnose and get ready to deliver full power. Hence, always switch on the load(s) after a few seconds of switching on the inverter. Avoid switching on the inverter with the load already switched on. This may prematurely trigger the overload protection. When a load is switched on, it may require initial higher power surge to start. If multiple loads are being powered, they should be switched on one by one so that the inverter is not overloaded by the high starting surge if all the loads are switched on at once.



**USE CARE**

**Turn the charge current control switch gently to avoid breakage due to over-turning.**

## 2.5.2 AC Charger

The 3000 watt inverter charger is equipped with an active PFC (Power Factor Corrected) multistage battery charger. The PFC feature is used to control the amount of power used to charge the batteries in order to obtain a power factor as close as possible to 1.

Unlike other inverters whose max charging current decreases according to the input AC voltage, this Global LF series charger is able to output max current as long as the input AC voltage is in the range of 95-127VAC, and AC freq is in the range of 48-54Hz(58-64Hz for 60Hz model).

It has a very rapid charge current available, and the max charge current can be adjusted from 15%-100% via a liner switch to the right of the battery type selector. This will be helpful if you are using our powerful charger on a small capacity battery bank. The liner switch can effectively reduce the max charging current to 15% of its peak.

Choosing “0” in the battery type selector will disable the charging function.

There are 3 charging stages:

**Bulk Charging: (*fast charge LED solid*)** This is the initial stage of charging. While Bulk Charging, the charger supplies the battery with controlled constant current. The charger will remain in Bulk charge until the Absorption charge voltage (determined by the Battery Type selection) is achieved.

A software timer will measure the time from A/C start until the battery charger reaches 0.3V below the boost voltage, then take this time as  $T_0$  and  $T_0 \times 10 = T_1$ .

**Absorb Charging: (*fast charge LED blinking*)** This is the second charging stage and begins after the absorb voltage has been reached. Absorb Charging provides the batteries with a constant voltage and reduces the DC charging current in order to maintain the absorb voltage setting.

In this period, the inverter will start a  $T_1$  timer; the charger will keep the boost voltage in Boost CV mode until the  $T_1$  timer has run out. Then drop the voltage down to the float voltage. The timer has a minimum time of 1 hour and a maximum time of 12 hours.

**Float Charging: (*float charge LED solid*)** The third charging stage occurs at the end of the Absorb Charging time. While Float charging, the charge voltage is reduced to the float charge voltage (determined by the Battery Type selection\*). In this stage, the batteries are kept fully charged and ready if needed by the inverter. If the A/C is reconnected or the battery voltage drops below 12Vdc/24Vdc, the charger will restart the above cycle.

If the charge maintains the float state for 10 days, the charger will deliberately reset the cycle to protect the battery.

Curves in Figure 5 show the current and voltage in the battery charging process.

# Battery Charging Processes

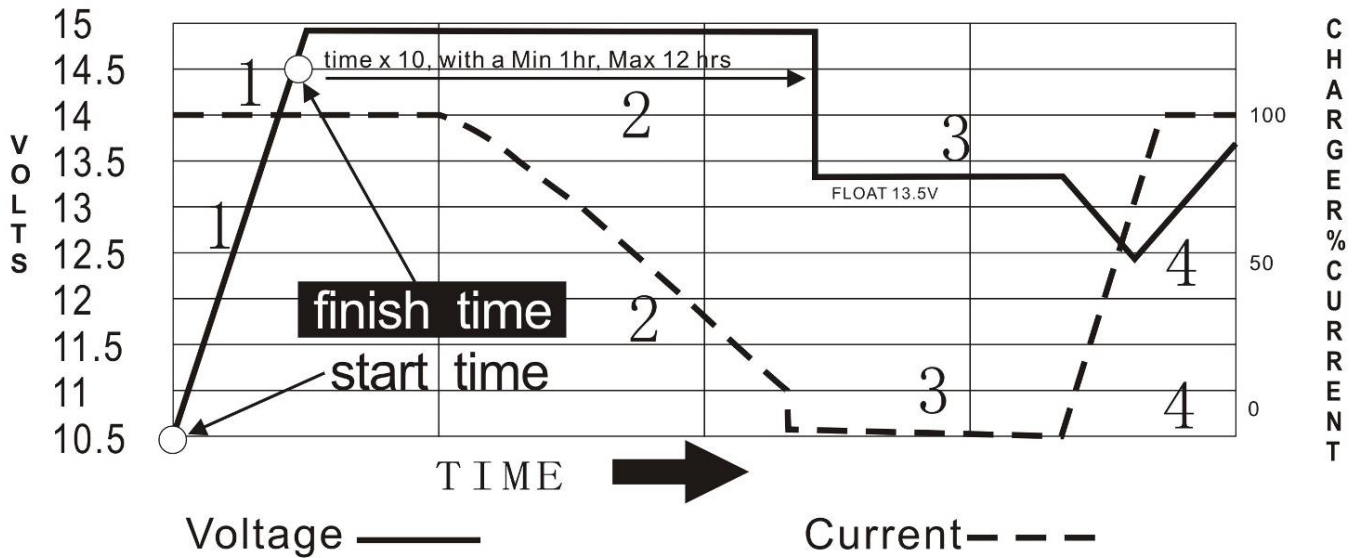

THE NEW BATTERY CHARGERS AND BOOSTERS OFFER THE FASTEST CHARGE RATE CURRENTLY AVAILABLE

STEP 1= Bulk Charge (Constant Current)  
STEP 3= Float Voltage

STEP 2 = Absorption (Constant Voltage)  
STEP 4 = RESET TO STEP 1

ADJUSTABLE TIME DEPENDING ON BATTERY BANK CAPACITY

Figure 5

Battery Type Selector Settings			
Switch Position	Description	Boost / Vdc	Float / Vdc
0	Charger Off		
1	Gel USA	14.0	13.7
2	AGM 1	14.1	13.4
3	AGM 2	14.6	13.7
4	Sealed lead acid   LiFePO4	14.4	13.6
5	Gel EURO	14.4	13.8
6	Open lead acid	14.8	13.3
7	Calcium	15.1	13.6
8	De-sulphation	15.5 (4 Hours then Off)	
9	Not used or customized*		

Above figures based on 12Vdc models.

\*For some customized models, position 9 is programmed with a customized algorithm. Please refer to the product label or the manufacturer for more information.

## De-sulphation

The de-sulphation cycle, switch position 8, is marked in red because this is a very dangerous setting if you do not know what you are doing. Before attempting to use this cycle you must clearly understand what it does, when and how you would use it.

What causes sulphation? This can occur with infrequent use of the batteries, or if the batteries have been discharged so low that they will not accept a charge. This cycle is a very high voltage charge cycle designed to try to break down the sulphated crust that is preventing the plates from taking a charge and thus allow the plates to clean up and accept a charge once again.

## CHARGING DEPLETED BATTERIES

The inverter allows start up and through power with depleted batteries even after low voltage shutdown. As long as you do not cycle the power or disconnect the battery. The charging can be activated when battery drops below 9V if AC is applied to input inverter.

The charging capacity will go to peak charge rate in about 3 seconds. This may cause a generator to drop frequency, making the inverter transfer to battery mode.

It is suggested to gradually put the charging load on the generator by switching the charging switch from min to max. Together with the 15s switch delay our inverter gives the generator enough time to spin up. This will depend on the size of the generator and rate of charge.

As a general Rule, the Bulk Charging Current should be limited to 30% of the capacity of the battery bank. Higher charging current may be used if permitted by the battery manufacturer.

**Caution:** Use a small jeweler's style flat-head screwdriver to GENTLY turn the charge current control switch to avoid breakage due to over-turning.



**To guarantee the best performance of the AC charger when the AC input is from a generator, the standby generator should be of at least 150% higher capacity than the inverter.**

**Operation with an under-rated generator or generator with unqualified wave form may cause premature failure, which is not covered under warranty.**

### 2.5.3 Transfer

#### Swift Power Transfer

While in the Standby Mode, the AC input of the inverter is continually monitored. Whenever AC power falls below the low AC voltage trip voltage (90VAC default setting for 120VAC), the inverter automatically transfers back to the Invert Mode with minimum power interruption to your appliances - as long as the inverter is turned on. The transfer from Standby mode to inverter mode occurs in approximately 10 milliseconds. And it is even shorter from inverter mode to Standby mode.

This transfer time is usually fast enough to keep your equipment (including computers) powered up, thus our inverter can be used as a line interactive UPS in applications that allow for 10ms transfer.



### Synchronized Power Transfer

When a load is transferred from inverter AC output to another backup AC source of power through the transfer switch, there will be an interruption of power to the load for the transfer to take place.

A mismatch of phase and frequency of the inverter AC output and the backup AC source in transfer is likely to damage the backup AC source / a reactive load.

With sophisticated circuitry design, our inverter will first lock on the frequency and phase of the input shore power/generator power and make a smooth and safe transfer at the zero voltage point to minimize the impact on the power modules.

### Transfer Delay

There is a 15-second delay from the time the inverter senses that continuously qualified AC is present at the input terminals to when the transfer is made. This delay is built in to provide sufficient time for a generator to spin-up to a stable voltage and frequency and avoid relay chattering. The inverter will not transfer to generator until it has locked onto the generator’s output. This delay is also designed to avoid frequent switching when input utility is unstable.

## 2.5.4 Power Saver

There are two different working statuses for the inverter: “Power On” and “Power Off”.

When the power switch on power switch panel (Figure 7) is in “Unit Off” position, the inverter is powered off.

When the power switch is turned to either of “Power Saver Auto” or “Power Saver Off”, the inverter is powered on.

Power saver function is designed to conserve battery power when AC power is not or rarely required by the loads.

In this mode, the inverter pulses the AC output looking for an AC load (i.e., electrical appliance). Whenever an AC load (greater than 50 watts) is turned on, the inverter recognizes the need for power and automatically starts inverting and output goes to full voltage. When there is no load (or less than 50 watts) detected, the inverter automatically goes back into search mode to minimize energy consumption from the battery bank.

In “Power saver on” mode, the inverter will draw power mainly in sensing moments, thus the idle consumption is significantly reduced.

The inverter is factory defaulted to detect load for 250ms every 3 seconds. This power sensing can be customized to “Unit off charging” via the SW3 on DIP switch.

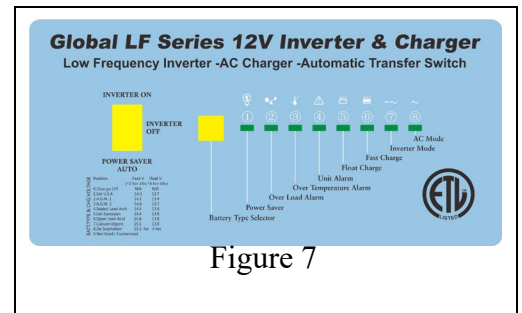

Figure 7

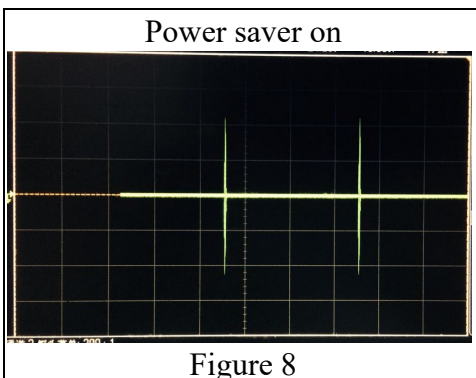

Figure 8

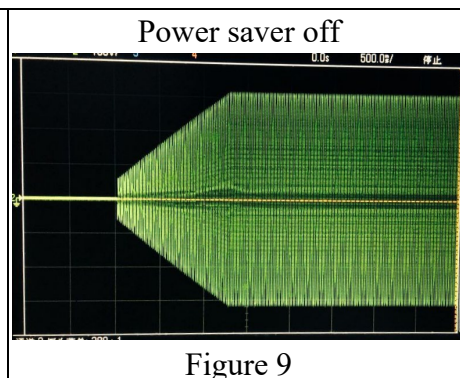

Figure 9

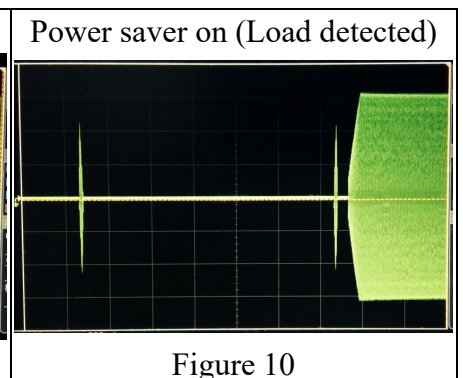

Figure 10



Note: The minimum power of a load to take inverter out of sleep mode (Power Saver On) is 50 Watts. For split phase models, the power threshold of sleep mode is 50W between Hot1 and Neutral and 200W between Hot 1 and Hot 2. There is no load detection between Hot2 and Neutral.

This inverter is designed with extraordinarily low idle power consumption of a mere 0.8-1.8% of its rated power. Power Saver Off = 55 watts. Power Saver On (3 Secs) 21.7 watt

When in the search sense mode, the green power LED will blink and the inverter will make a ticking sound. At full output voltage, the green power LED will light steadily and the inverter will make a steady humming sound. When the inverter is used as an “uninterruptible” power supply the search sense mode or “Power Saver On” function should be defeated.

### **Exceptions**

Some devices when scanned by the load sensor cannot be detected. Small fluorescent lights are the most common example. (Try altering the plug polarity by turning the plug over.) Some computers and sophisticated electronics have power supplies that do not present a load until line voltage is available. When this occurs, each unit waits for the other to begin. To drive these loads either a small companion load must be used to bring the inverter out of its search mode, or the inverter may be programmed to remain at full output voltage (Power On mode).

## **2.5.5 Protections**

The Global LF series inverter is equipped with extensive protections against various harsh situations/faults. These protections include:

- AC Input over voltage protection/AC Input low voltage protection
- Low battery alarm/High battery alarm
- Over temperature protection/Over load protection
- Short Circuit protection (1s after fault)
- Back feeding protection

When over temperature /over load occur, and after the fault is cleared, the master switch needs to be reset to restart the inverter.

The low battery voltage trip point can be customized from a defaulted value of 10VDC to 10.5VDC using SW1 on the DIP switch.

The inverter will go to over temp protection when the heat sink temp is over 105°C(221°F), and go to Fault (shutdown Output) after 30 seconds. The switch needs to be reset to activate the inverter.

The AIMS Power inverter also has back feeding protection, which avoids presenting an AC voltage on the AC input terminal in Invert mode.

After the reason for the fault is cleared, the inverter needs to be reset to start working.

### 2.5.6 Remote Control

Apart from the switch panel on the top side of the inverter, an optional LCD remote switch panel (Figure 11, sold separately Part #: REMOTELF) connected to the remote port at the DC side of the inverter can also control the operation of the inverter.

If an extra switch panel is connected to the inverter via “remote control port”, together with the panel on the inverter case, the two will be connected and operated in parallel.

Whichever first switches from “Off” to “Power saver off” or “Power saver on”, it will power on the inverter. If the commands from the two panels conflict, the inverter will operate according to the following priority:

Power saver on> Power saver off> Power off

Only when both panels are turned to the “Unit Off” position, will the inverter be powered off.

Figure 11

The Max length of the LCD remote control data cable is 60 feet (18 meters).

The LCD remote control panel will display the operation status of the inverter,

including:

- Input AC Voltage
- Output AC Voltage
- Battery Voltage
- Output Frequency
- Output Load
- Work Mode
- Alarm
- Fault
- Battery Capacity

A push button on the left of the panel can be used to turn off the LCD screen and save 0.1A current draw on the battery.



REMOTE LCD SCREEN

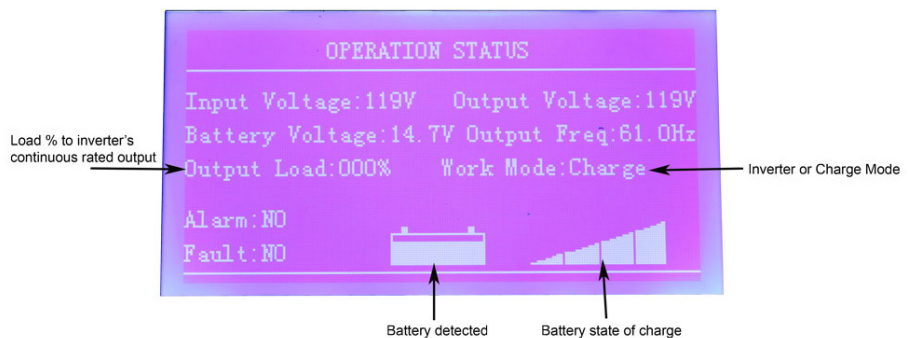

Never cut the Ethernet cable when the cable is attached to inverter and battery is connected to the inverter. Even if the inverter is turned off, it will damage the remote PCB inside if the cable is short circuited during cutting and not covered under warranty.

## 2.5.7 LED Indicator

The operation status of the inverter is shown by the LED's and the explanation on the LED sticker (Figure 12).

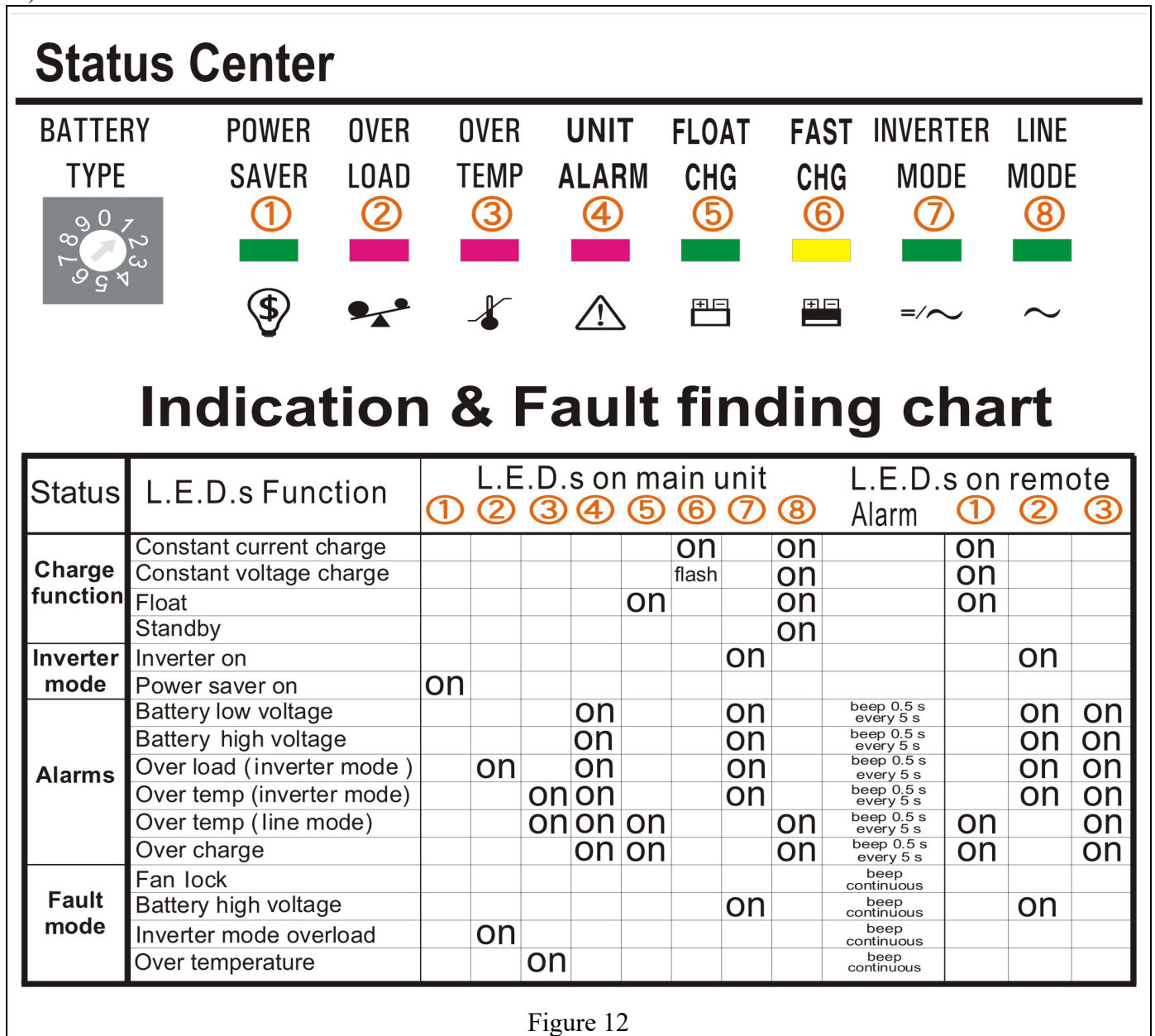

## 2.5.8 Audible Alarm

The inverter also gives audible alarms when the following situations occur.

<b>Battery Voltage Low</b>	Inverter green LED lit, and the buzzer beeps 0.5s every 5s.
<b>Battery Voltage High</b>	Inverter green LED lit, and the buzzer beeps 0.5s every 1s and Fault after 60s.
<b>Invert Mode Over-Load</b>	(1) $110% < \text{load} < 125% (\pm 10\%)$ , No audible alarm in 14 minutes, Beeps 0.5s every 1s in 15 <sup>th</sup> minute and Fault after 15 minutes; (2) $125% < \text{load} < 150% (\pm 10\%)$ , Beeps 0.5s every 1s and Fault after 60s; (3) $\text{Load} > 150% (\pm 10\%)$ , Beeps 0.5s every 1s and Fault after 20s;
<b>Over Temperature</b>	Heat sink temp. $\geq 105^{\circ}\text{C} (221^{\circ}\text{F})$ , Over temp red LED Lighting, beeps 0.5s every 1s;

## 2.5.9 FAN Operation

There is one variable speed controlled DC fan.

The operation of the DC fan on the DC terminal side is controlled by the following logic:

Condition	Enter Condition	Leave condition	Speed
<b>HEAT SINK TEMPERATURE</b>	$T \leq 60^{\circ}\text{C}(140^{\circ}\text{F})$	$T > 65^{\circ}\text{C}(149^{\circ}\text{F})$	OFF
	$65^{\circ}\text{C}(149^{\circ}\text{F}) \leq T < 85^{\circ}\text{C}(185^{\circ}\text{F})$	$T \leq 60^{\circ}\text{C}(140^{\circ}\text{F})$ or $T \geq 85^{\circ}\text{C}(185^{\circ}\text{F})$	50%
	$T > 85^{\circ}\text{C}(185^{\circ}\text{F})$	$T \leq 80^{\circ}\text{C}(176^{\circ}\text{F})$	100%
<b>CHARGER CURRENT</b>	$I \leq 15\%$	$I \geq 20\%$	OFF
	$20\% < I \leq 50\%\text{Max}$	$I \leq 15\%$ or $I > 50\%\text{Max}$	50%
	$I > 50\%\text{Max}$	$I \leq 40\%\text{Max}$	100%
<b>LOAD Percentage (INV MODE)</b>	Load $< 30\%$	Load $\geq 30\%$	OFF
	$30\% \leq \text{Load} < 50\%$	Load $\leq 20\%$ or Load $\geq 50\%$	50%
	Load $\geq 50\%$	Load $\leq 40\%$	100%

Allow at least 12" of clearance around the inverter for air flow. Make sure that the air can circulate freely around the unit.

Fan noise level  $< 60\text{db}$  at a distance of 1m

## 2.5.10 DIP Switches

On the DC end of inverter, there are five DIP switches which enable users to customize the performance of the device.

Switch #	Switch Function	Position: 0	Position: 1
SW1(Utility Priority)	Low Battery Trip Point	10.0VDC	10.5VDC
SW1(Battery Priority)		10.5VDC	11.5VDC
SW2	AC Input Range	100-135VAC	90-135VAC(40Hz+)
SW3	Power Save Override ON/OFF	Inverter Off	Power Saver On( 3 sec)
SW4	Frequency Switch	50Hz	60Hz
SW5	Battery/AC Priority	AC Priority	Battery Priority

### Low Battery Trip Point (SW1):

Deep discharge of the lead acid battery leads to high losses in capacity and early aging. In different applications a different low voltage disconnection level is preferred. For example, for solar applications, user may intend to have less DOD to prolong the battery life cycle. While for mobile applications users may intend to have more DOD to reduce battery capacity and on board weight.

For 12VDC models, when the inverter is in AC priority mode (SW5 at "0"), Low Battery Trip Point is selectable at 10.0/10.5VDC. It can be customized to 10.5/11.5VDC via SW5. This is to prevent batteries from over-discharging while there is only a small load applied on the inverter.

### AC Input Range (SW2):

There are different acceptable AC input ranges for different kinds of loads.

For some relatively sensitive electronic devices, a narrow input range of 100-135V is required to protect them.

While for some resistive loads which work in a wide voltage range, the input AC range can be customized to 90-135V, this helps to power loads with the most AC input power without frequent switches to the battery bank.

In order to make the inverter accept dirty power from a generator, when the SW2 is switched to position “1”, the inverter will bypass an AC input with a wider voltage and frequency (40Hz plus for 50Hz/60Hz).

Accordingly, the AC charger will also work in a wider voltage and freq range (43Hz plus for 50Hz/60Hz).

This will avoid frequent switches between battery and generator. But some sensitive loads will suffer from the low quality power.

The pros and cons should be considered. When using a generator see page 13 for generator size recommendation.

### **Power Save Override ON/OFF (SW3):**

Under the Battery Priority Mode (SW5 in position “1”), the inverter can be switched between two modes: Power Saver Mode (SW3 in position “1”) and Unit Off Charging Mode (SW3 in position “0”). The power Switch should be in “Power saver on” position all the time for using these functions.

In Power Saver Mode, the inverter is initially in standby mode and sends a pulse to detect the presence of a load every 3 seconds. Each pulse lasts for 250ms. The inverter will remain in standby mode until a load has been detected. Then it will wake up from standby mode and start to invert electricity from the battery bank to supply the load. As this function is under Battery Priority, the inverter will always prefer to invert electricity from battery first even if there is a qualified AC input present. Only when the battery voltage is lower than the low voltage alarm point, will the inverter switch to AC input power to charge the battery and supply the load at the same time.

This Power Saver Mode can be changed to Unit Off Charging mode via SW3 by switching it to “0” position (SW5 still in “1”).

In Unit Off Charging mode, the inverter will stay in standby mode without sensing loads. It won't output any power even if a load is turned on or a qualified AC input is present. The inverter will not perform any function and only stay idle in this mode, unless the battery voltage is low. Then it will start charging the battery. This feature is ideally suitable for applications where energy conservation is required. Charging will only be activated when required.

### **Frequency Switch (SW4):**

The output frequency of the inverter can be set at either 50Hz or 60Hz by SW4.

### **AC/Battery Priority (SW5):**

Our inverter is designed with AC priority by default. This means, when AC input is present, the battery will be charged first, and the inverter will transfer the input AC to power the load. Only when the AC input is stable for a continuous period of 15 days will the inverter start a battery inverting cycle to protect the battery. After 1 normal charging cycle AC throughput will be restored.

The AC Priority and Battery Priority switch is SW5. When you choose battery priority, the inverter will invert from battery despite the AC input. Only when the battery voltage reaches the low voltage alarm point(10.5Vdc for 12Vdc, 21Vdc for 24Vdc, 42Vdc for 48Vdc), will the inverter transfer to AC input, charge battery, and switch back to battery when the battery is fully charged. This function is mainly for wind/solar systems using utility power as back up.

**Note: In battery priority mode, when qualified AC inputs for the first time and the battery voltage is below 12.5Vdc (12.5Vdc for 12Vdc, 25Vdc for 24Vdc, 51Vdc for 48Vdc), the inverter will go into battery priority mode only after a cycle of bulk charging and absorb charging is finished. The inverter will not go into float charging mode.**

## 2.5.11 Auto Generator Start

The inverter can start up a generator when battery voltage goes low.

When the inverter goes to low battery alarm, it can send a signal to start a generator and turn the generator off after battery charging is finished.

The auto gen start feature will only work with generators which have automatic starting capability. The generator must have start and stop controls [an electric starter and electric choke (for gasoline units)], and the safety sensors to be able to start and stop automatically.

There is an open/close relay that will short circuit the positive and negative cables from a generator start control. The input DC voltage can vary, but the max current the relay can carry is 16Amp.

The Auto Generator Start terminal pins are not polarized.

In addition, these two pins can also be used as dry contacts to send out “Low Battery Voltage” signal to an external alarm device.

## 2.5.12 Battery Temperature Sensing

Applying the proper charge voltage is critical for achieving optimum battery performance and longevity.

The ideal charge voltage required by batteries changes with battery temperature.

The battery temperature sensor allows the charge controller to continuously adjust charge voltage based on actual battery temperature.

Temperature compensation of charge voltage assures that the battery receives the proper charge voltage as battery temperature varies.

The entire line is equipped with Battery Temperature Sensing for increased charging precision.

It sends precise information to the charger, which automatically adjusts voltage to help ensure full battery charge depending on the ambient temperature of your battery installation.

When the battery is over 40°C (104°F), it will reduce the charging voltage by 0.1Vdc with every degree of temperature rise.

We recommend that you install Battery Temperature Sensors on all banks to protect your batteries and to provide optimal charging of each bank.

The battery temperature sensor mounts on the side of a battery or any other location where the precise temperature of battery can be detected such as battery mounting racks.

The following table describes approximately how much the voltage may vary depending on the temperature of the batteries.

Inverter Condition	Temperature on BTS	Charger Operation
Charger Mode	$BTS \geq 50^{\circ}\text{C} (122^{\circ}\text{F})$	Automatically turns off charger
	$BTS \leq 40^{\circ}\text{C} (104^{\circ}\text{F})$	Automatically turns on charger
Inverter Mode	$40^{\circ}\text{C} (104^{\circ}\text{F}) \leq BTS \leq 50^{\circ}\text{C} (122^{\circ}\text{F})$	Increases low voltage shut down point by 0.5Vdc
	$BTS \geq 50^{\circ}\text{C} (122^{\circ}\text{F})$	Over Temp Fault

An optional Battery Temperature Sensor is available (Part #: PICGLFBATS). Includes 32.8'/10m cable.



Figure 13

**Important:** If the battery temperature is allowed to fall to extremely cold temperatures, the inverter with a BTS may not be able to properly recharge cold batteries due to maximum voltage limits of the inverter. Ensure the batteries are protected from extreme temperatures. For more detailed technical information, please contact us.

## 2.5.13 Other Features

### Battery voltage recovery start

If inverter powers down because of low battery voltage, the inverter will power up once the battery voltage recovers to operating voltage (with power switch still in “On” position).



### WARNING

Never leave the loads unattended, some loads (like a heater) may cause accidents in such cases. It is better to shut everything off after low voltage trip than to leave your load on and risk fire.

### Conformal Coating

This entire line of inverters has been processed with a conformal coating on the PCB, making it water, rust, and dust resistant.

While these units are designed to withstand corrosion from the salty air, they are not splash proof.

## 3 Installation

### 3.1 Unpacking and Inspection

Carefully remove the inverter from its shipping package and inspect all contents. Verify the following items are included:

- The PICOGLF inverter
- AC terminal block cover with two Phillips screws
- Two Flange nuts and 4 Phillips screws (installed on the DC terminals).
- PICOGLF Series Owner’s Manual

If items appear to be missing or damaged, contact our authorized dealer or us. If at all possible, keep your shipping box. It will help protect your inverter from damage if it ever needs to be returned for service. Save your proof-of-purchase as a record of your ownership; it will also be needed if the unit should require warranty work.

### 3.2 Installation Location, Tools & Materials

Follow all the local regulations to install the inverter.

Install the equipment in an INDOOR location that is dry, clean, cool, free from dust and with good ventilation. Working temperature: -10°C to 40°C (-14°F to 104°F)

Storage temperature: -40 to 70°C (-40°F to 158°F)

Relative Humidity: 0% to 95%, non-condensing

Cooling: Forced air

**CAUTION:** The inverter is heavy. Use proper lifting techniques during installation to prevent personal injury. All hardware and surfaces must support the weight of the inverter.



## **WARNING!**

The inverter should not be installed in an area that allows dust, fumes, insects or rodents to enter or block the inverter's ventilation openings.

This area also must be free from any risk of condensation, water or any other liquid that can enter or fall on the inverter.

While these units are designed to withstand corrosion from the salty air, they are not splash proof.

The inverter's life is uncertain if used in these types of environments, and inverter failures under these conditions are not covered under warranty.

**Applicable installation codes vary depending on the specific location and application of the installation. Some examples are:** • The U.S. National Electrical Code (NEC) • The Canadian Electrical Code (CEC) • Canadian Standards Association (CSA) and RV Industry Association (RVIA) for installation in RVs. Please follow the code that is in effect at the time of installation.

## **Installation Tools / Materials**

### **Tools**

You will need the following tools to install the Global LF series inverters and the battery temperature sensor.

- Wire stripper
- Crimping tools for fastening lugs and terminals on DC cables
- Phillips screwdriver: #2
- Slot screwdriver (1/4" wide blade max.)
- Needle-nose pliers
- Wrench for DC terminals: 9/16"

### **Materials**

You will need the following materials to complete your installation:

- correct size DC battery cables
- Terminals and/or crimp connectors for DC cables
- Copper wire for DC grounding: No. 8 AWG.
- Terminal or crimp connector for DC grounding cable (for 1/4" stud size)
- AC output and input wire.
- If the AC ground wire is stranded, each ground wire requires a ring terminal
- Six 1/4"-20 1.25" length steel screws or bolts to mount the inverters

## **3.3 DC Wiring**

It is recommended that the battery bank be kept as close as possible to the inverter. For applications up to 12 feet, use 4/0 AWG good quality cable.



Performance of any product can be improved by thicker cable and shorter runs, so if in doubt round up and keep the length as short as possible.

Battery cables must have crimped (or preferably, soldered and crimped) copper compression lugs unless aluminum mechanical lugs are used. Soldered connections alone are not acceptable. High quality, UL-listed battery cables are available. These cables are color-coded with pressure crimped, sealed ring terminals.

Battery terminal must be clean to reduce the resistance between the DC terminal and cable connection. A buildup of dirt or oxidation may eventually lead to the cable terminal overheating during periods of high current draw. Use a stiff wire brush and remove all dirt and corrosion from the battery terminals and cables.

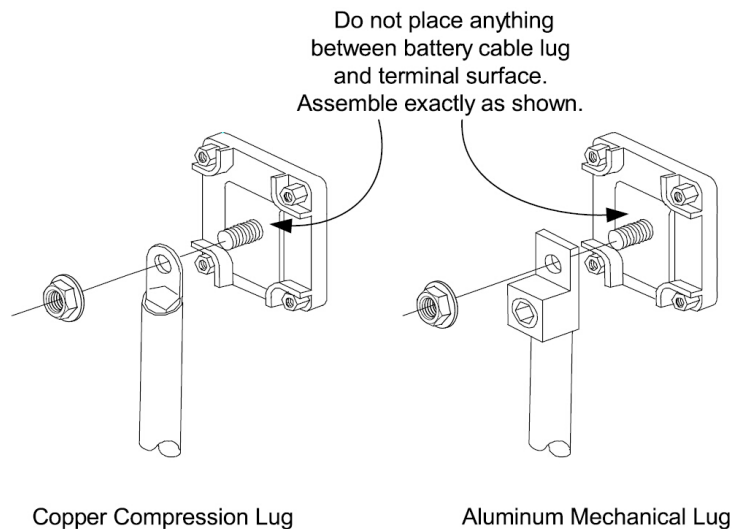



Figure 14

### Reducing RF interference

To reduce the effect of radiated interference, twist the DC cables. To further reduce RF interference, shield the cables with sheathing /copper foil / braiding.

### Taping battery cables together to reduce inductance

Do not keep the battery cables far apart. In case it is not convenient to twist the cables, keep them taped together to reduce their inductance. Reduced inductance of the battery cables helps to reduce induced voltages. This reduces ripple in the battery cables and improves performance and efficiency.



 <b>WARNING</b>	<p>The torque rating range for DC terminal is 12.5NM-20.5NM (9.25-15.19 pound-foot), and the suggested torque rating is 17NM (12.6 pound-foot). Over torquing may break the bolt.</p>
	<p><b>Equipment Damage</b>            The inverter is not reverse polarity protected. Reversing the battery polarity on the DC input connections will cause permanent damage to the inverter which is not covered under warranty. Always check polarity before making connections to the inverter.</p>
	<p>The inverter contains capacitors that may produce a spark when first connected to battery. Do not mount in a confined compartment with vented battery or gases.</p>
	<p>Ensure the inverter is off before disconnecting the battery cables, and that AC power is disconnected from the inverter's input.</p>

### 3.4 AC Wiring

AIMS Power recommends using 4 AWG wire to connect to the AC terminal block.

When in AC mode the AC input power will supply both the loads and AC charger, a thicker wire gauge for AC Input is required. Please consult a qualified electrician about the specific wire gauge required in terms of wire material and inverter power.

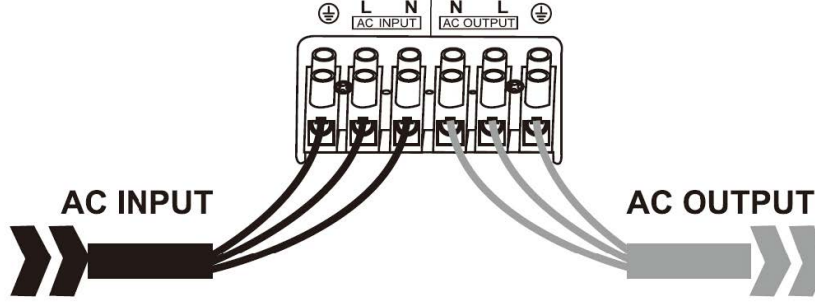
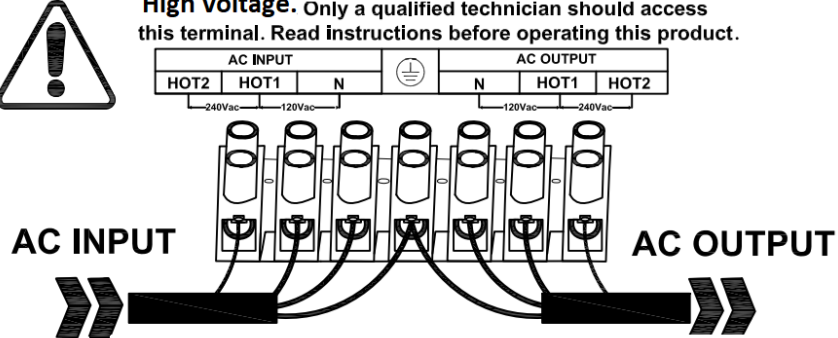
Call our tech support if you are not sure about how to wire any part of your inverter.

<p><b>Wiring Diagram</b></p> <p>120V single phase          Input: Hot line + Neutral + Ground          Output: Hot line + Neutral + Ground</p>	
<p><b>Wiring Diagram</b></p> <p>Inverter Model:          PICOGLF3K12050BY</p> <p>Input: If 240V          Hot 2 + Hot 1 + Neutral +Ground  <math>H2+N=120V</math> <math>H1+N=120V</math>  <math>H1+H2=240V</math>          Output: at 120/240V          Hot 1 +Neutral + Hot 2 +Ground  <math>H1-N=120V</math> <math>H2-N=120V</math> <math>H1-H2=240V</math>          OR          Input if 120V          H1 + neutral + ground  <math>H1-N=120V</math>          Output at 120V</p> <p>Inverter mode          Output:          Hot 1 + Neutral + Ground 120V  <math>H1-N=120V</math></p>	<p><b>High voltage. Only a qualified technician should access this terminal. Read instructions before operating this product.</b></p> 
 <p><b>WARNING</b></p>	<p><b>The output voltage of this unit must never be connected in its input AC terminal, overload or damage may result.</b></p> <p><b>Always switch on the inverter before plugging in any appliance.</b></p> <p><b>Damages caused by AC wiring mistakes are not covered under warranty.</b></p>

The AC terminal output is not ground fault protected.

Installation in recreational vehicles requires GFCI protection of certain branch circuits. Consult all applicable codes.

Tested GFCIs Compliance with UL standards requires that AIMS test and recommend specific GFCIs for use on the output of the inverter.

Table 1 lists models that have been tested and will function properly when connected to the AC output of the Inverters.

Table 1 Tested GFCI Models

Manufacturer/ Model Number
Hubbell / GFR5252WA
Leviton / 8599-GY
Pass & Seymour / 1594-W

### Preventing Paralleling of the AC Output

The AC output of the unit should never be connected to the utility power / generator.

Such a connection may result in parallel operation of the different power sources and AC power from the utility / generator will be fed back into the unit which will instantly damage the inverter and may also pose a fire and safety hazard.

## 3.5 Grounding

### 3.5.1 Grounding the Inverter Chassis

Connect an AWG 8 gauge or greater copper wire between the grounding terminal on the inverter and the earth grounding system or the vehicle chassis.

### 3.5.2 Automatic Neutral-to-Ground Connection

All single phase 120Vac inverters are equipped with automatic neutral-to-ground switching.

These inverters use an internal relay that automatically connects the AC neutral output to the vehicle/boat’s safety ground (“bonding” it) in Inverter Mode and disconnects it (“un-bonding” it) when they have connected to a qualified external AC source.

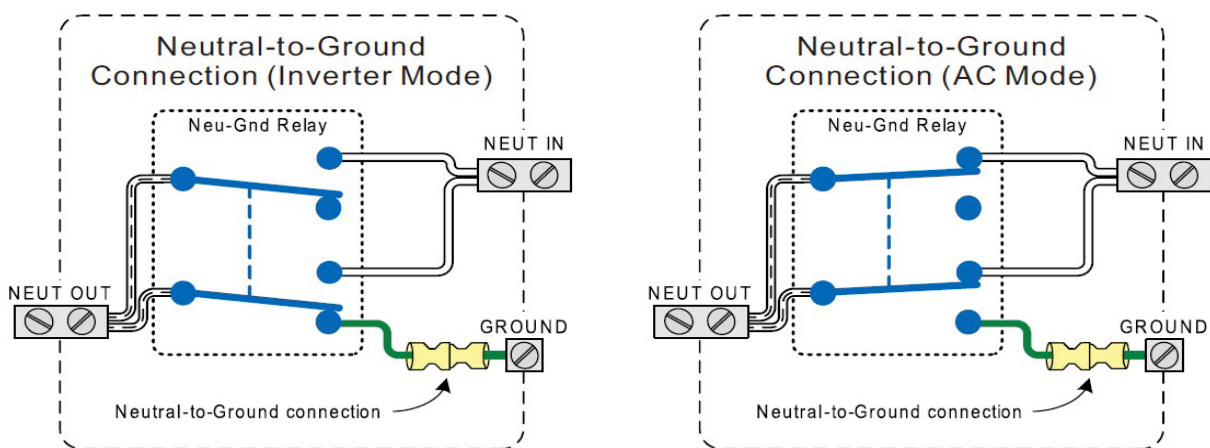

Figure 19

This design avoids two neutral-to-ground connections from existing at the same time, thereby preventing an electrical shock hazard between the vehicle/boat’s neutral and the external AC source’s neutral.

### **3.5.3 Disabling the Automatic Neutral-to-Ground Connection**

In some installations, this feature must be disabled.

To accommodate these situations, the automatic Neutral-to-Ground Connection system can be defeated, so it will not bond the neutral in any mode of operation.

If you are not sure whether you must disable this feature, please refer to your local code requirements.

There is a section of green wire with the insulated connector at the left side of the AC terminal block . This insulated connector connects the neutral and ground inside the inverter while inverting.

Pull the two ends of the insulated connector apart to separate the green wire ; this will prevent the neutral and ground from connecting inside this inverter.

If possible, use electrical tape to insulate the disconnected ends, move the two ends away from each other and push back out of the way. Typically when connecting to a house panel (after disconnecting city power from it) is when you would disconnect this connection as a house panel already has the neutral to ground bond . Typically in a standalone system or in a vehicle, you would want to keep this connection .

### 3.6 Mounting the Inverter

In order to mount the inverter securely, the surface and the mounting hardware must also be able to support at least twice the weight of the inverter. To meet regulatory safety requirements, the PICOGLF Series must be mounted:

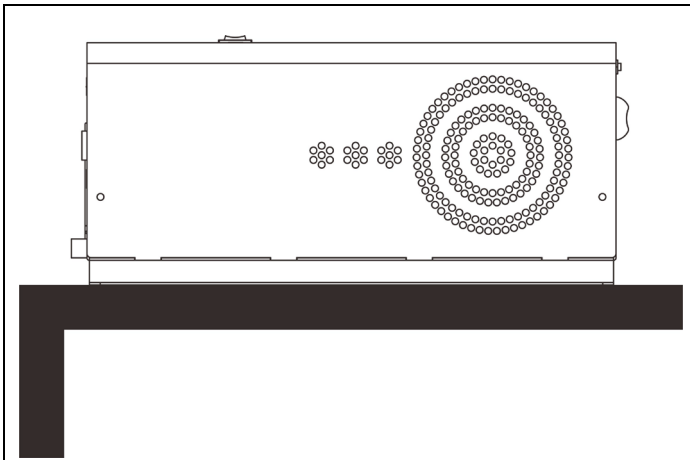

Figure 22

On a horizontal surface (shelf or table top) with top side up. Make sure surface can support the weight.

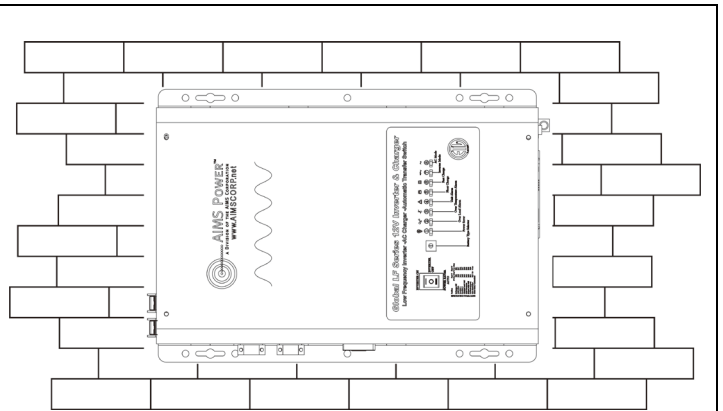

Figure 23

On a vertical surface (like a wall) with the DC terminals facing left and the fan axis horizontal.

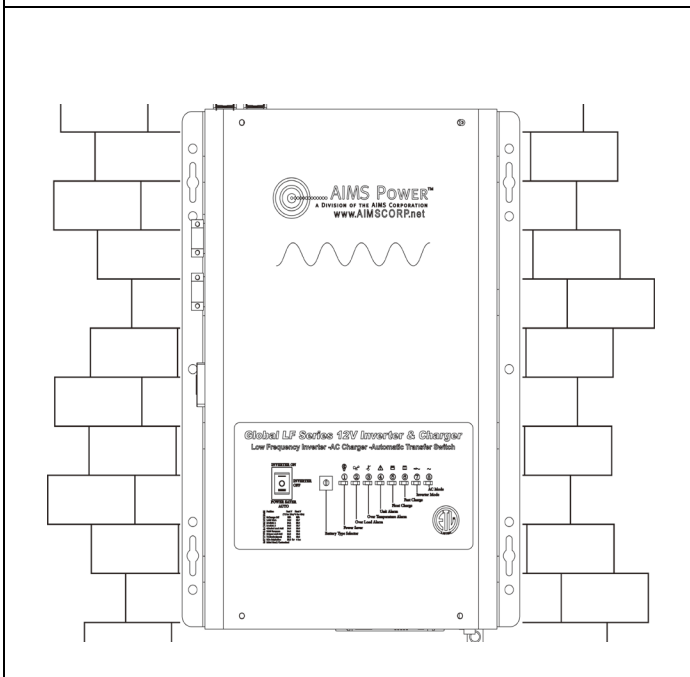

Figure 24

On a vertical surface (like a wall) with the DC terminals facing down and the fan axis vertical.

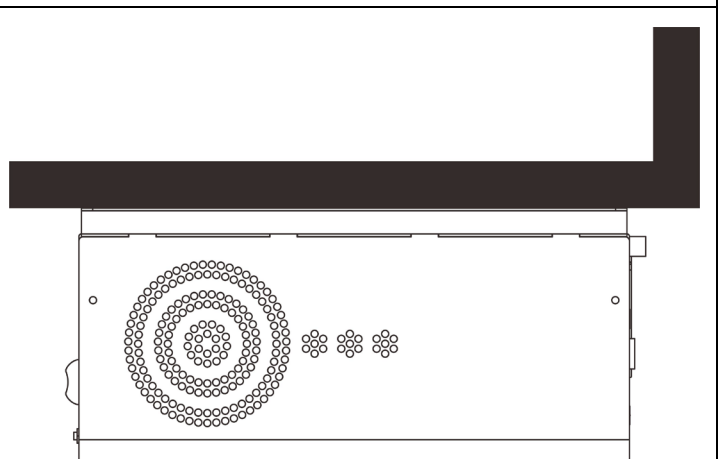

Figure 25

**DO NOT MOUNT UPSIDE DOWN (TOP SIDE FACING DOWN)**



**Warning!** The inverter surface may get as high as 80°C (176°F) during operation, do not touch. The unit should be installed so it is not likely to come into contact with people.

After determining the mounting position, refer to the physical dimensions as shown in the figures below or use the base of the inverter as a template to mark your mounting screw locations. After marking the mounting screw locations, mount the unit with appropriate mounting hardware.

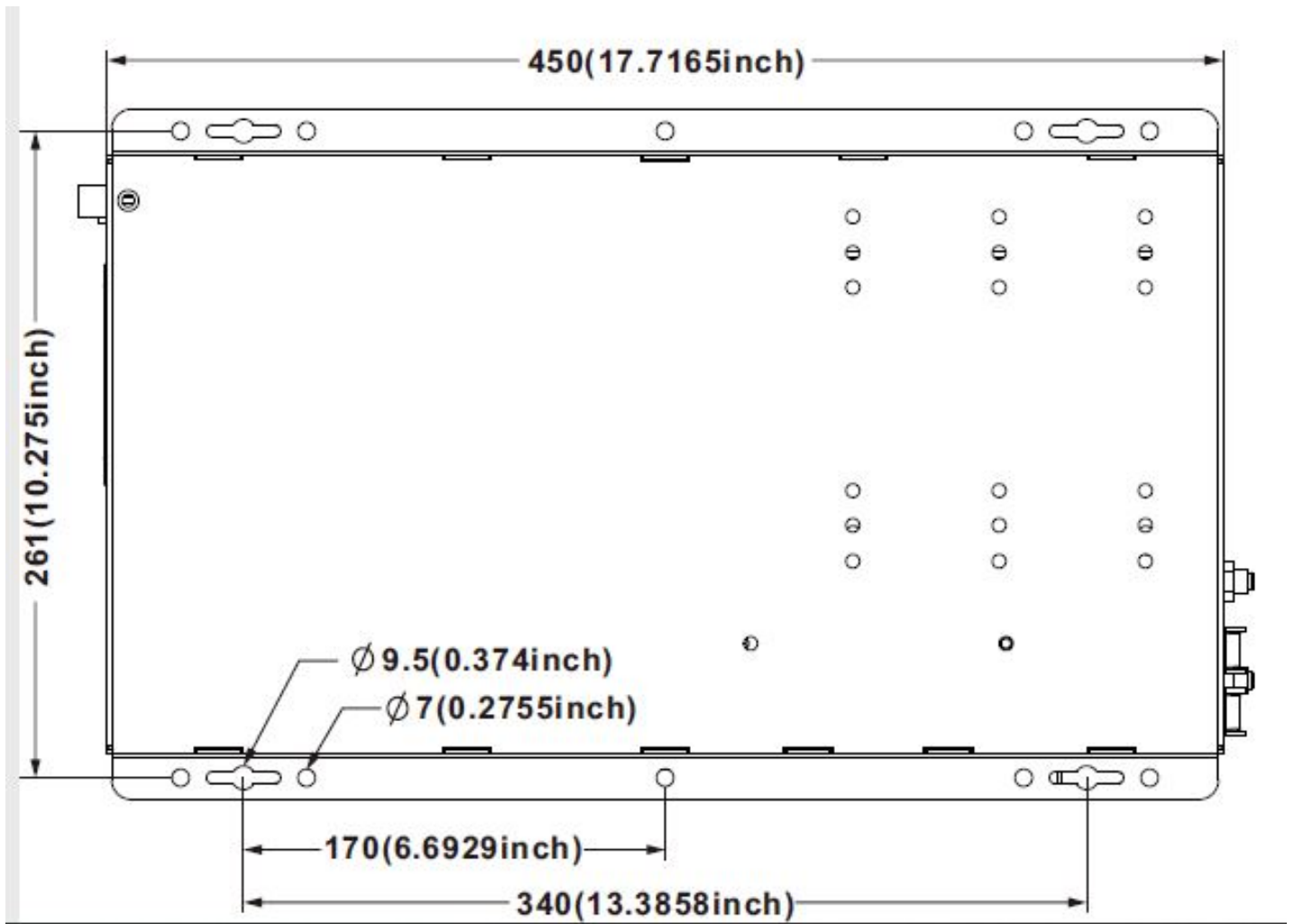
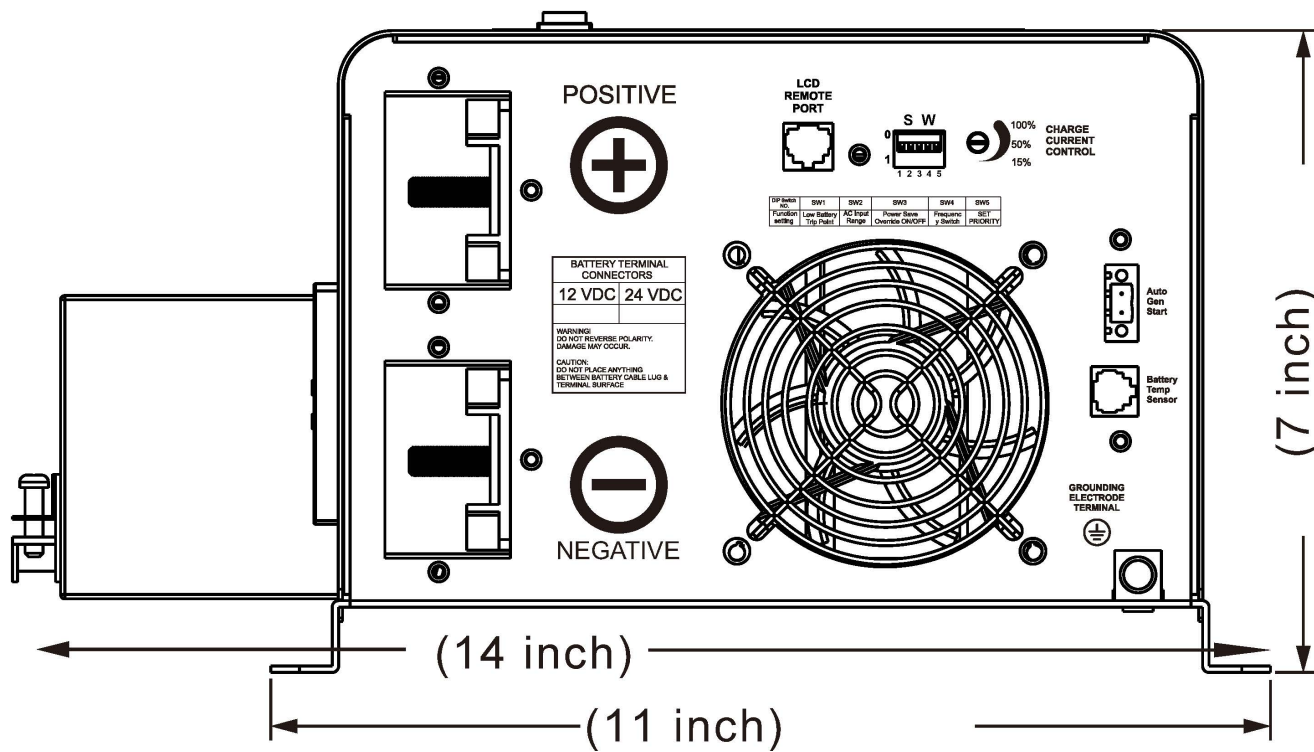

Figure 26



## 4 Troubleshooting Guide

Troubleshooting contains information about how to troubleshoot possible error conditions while using the Global LF Inverter & Charger.

The following chart is designed to help you quickly pinpoint the most common inverter failures.

### Indicator and Buzzer

Status	Item	Indicator on top cover							LED on Remote Switch			Buzzer
		SHORE POWER ON	INVERTER ON	FAST CHG	FLOAT CHG	OVER TEMP TRIP	OVER LOAD TRIP	POWER SAVER ON	BATT CHG	INVERTER	Alarm	
Line Mode	CC	√	×	√	×	×	×	×	√	×	×	×
	CV	√	×	√, blink	×	×	×	×	√	×	×	×
	Float	√	×	×	√	×	×	×	√	×	×	×
	Standby	√	×	×	×	×	×	×	×	×	×	×
Inverter Mode	Inverter On	×	√	×	×	×	×	×	×	√	×	×
	Power Saver	×	×	×	×	×	×	√	×	×	×	×
Inverter Mode	Low Battery	×	√	×	×	×	×	×	×	√	√	Beep 0.5s every 5s
	High Battery	×	√	×	×	×	×	×	×	√	√	Beep 0.5s every 1s
	Overload Invert Mode	×	√	×	×	×	√	×	×	√	√	Refer to “Audible



												alarm”
	<b>Over-Temp Invert Mode</b>	×	√	×	×	√	×	×	×	√	√	Beep 0.5s every 1s
	<b>Over-Temp Line Mode</b>	√	×	√	×	√	×	×	√	×	√	Beep 0.5s every 1s
	<b>Over Charge</b>	√	×	√	×	×	×	×	√	×	√	Beep 0.5s every 1s
<b>Fault</b>	<b>Fan Lock</b>	×	×	×	×	×	×	×	×	×	×	Beep continuous
	<b>Battery High</b>	×	√	×	×	×	×	×	×	√	×	Beep continuous
	<b>Overload Invert Mode</b>	×	×	×	×	×	√	×	×	×	×	Beep continuous
	<b>Output Short</b>	×	×	×	×	×	√	×	×	×	√	Beep continuous
	<b>Over-Temp</b>	×	×	×	×	√	×	×	×	×	×	Beep continuous
	<b>Over Charge</b>	×	×	√	×	×	×	×	×	√	×	Beep continuous
	<b>Back Feed Short</b>	×	×	×	×	×	×	×	×	×	×	Beep continuous

Symptom	Possible Cause	Recommended Solution
Inverter will not turn on during initial power up.	Batteries are not connected, loose battery-side connections.	Check the batteries and cable connections. Check DC fuse and breaker.
	Low battery voltage.	Charge the battery.
No AC output voltage and no indicator lights ON.	Inverter has been manually transitioned to OFF mode.	Press the switch to Power saver on or Power saver off position.
AC output voltage is low and the inverter turns loads OFF in a short time.	Low battery.	Check the condition of the batteries and recharge if possible.
Charger is inoperative and unit will not accept AC.	AC voltage has dropped out-of-tolerance	Check the AC voltage for proper voltage and frequency.
Charger is supplying a lower charge rate.	Charger controls are improperly set.	Refer to the section on adjusting the “Charger Rate”.
	Low AC input voltage.	Source qualified AC power.
	Loose battery or AC input connections.	Check all DC /AC connections.
Charger turns OFF while charging from a generator.	High AC input voltages from the generator.	Load the generator down with a heavy load. Turn the generator output voltage down.

Sensitive loads turn off temporarily when transferring between grid and inverting.	Inverter's low voltage trip voltage may be too low to sustain certain loads.	Choose narrow AC voltage in the DIP switch, or Install a UPS if possible.
Noise from Transformer/case*	Applying specific loads such as hair drier	Remove the loads

**\*The reason for the noise from transformer and/or case**

When in inverter mode sometimes the transformer and/or case of the inverter may vibrate and make noise. If the noise comes from transformer:

According to the characteristics of our inverter, there is one type of load which most likely may cause rattles of transformer.

That is a half wave load: A load that uses only half a cycle of the power. This tends to cause an imbalance of the magnetic field of the transformer, reducing its rated working freq from 20KHz to, say, maybe 15KHz (it varies according to different loads). In such a case the frequency of noise falls exactly into the range (200Hz-20KHz) that human ears can hear.

The most common load of such kind is a hair drier.

If the noise comes from the case:

Normally when loaded with inductive loads, the magnetic field generated by the transformer keeps attracting or releasing the steel case at a specific freq, this may also cause noise.

Reducing the load power or using an inverter with bigger capacity will normally solve this problem.

The noise will not do any harm to the inverter or the loads.

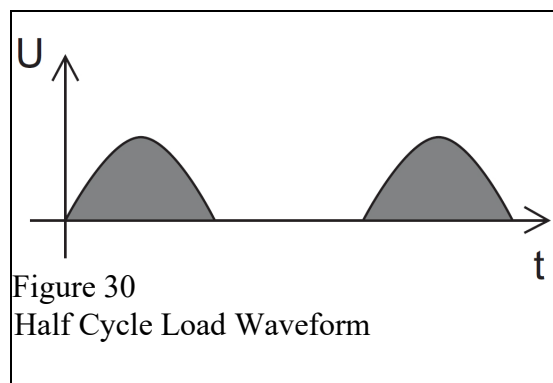

Figure 30  
Half Cycle Load Waveform

## 5 AIMS POWER LIMITED WARRANTY

This product is designed using the most modern digital technology and under very strict quality control and testing guide lines. If however you feel this product is not performing as it should, please contact us:

[techsupport@aimscorp.net](mailto:techsupport@aimscorp.net) or (775)359-6703.

We will do our best to resolve your concerns. If the product needs repair or replacement, make sure to keep your receipt/invoice, as that will need to be sent back along with the package and RA# prepaid to AIMS. You have a full 2 year from date of purchase warranty.

This warranty is valid world wide with the exception that freight and duty charges incurred outside the contiguous 48 United States will be prepaid by customer.

Except as provided above, AIMS makes no warranty of any kind, express or implied, including without limitation the implied warranties of merchantability and fitness for a particular purpose. In no event shall AIMS be liable for indirect, special or consequential damages. This warranty only applies to AIMS Power branded products. All other name brand products are warranted by and according to their respective manufacturer. Please do not attempt to return non-AIMS Power branded products to AIMS Power.

For additional products such as:

- Modified sine wave inverters
- Pure sine wave inverters
- Solar charge controllers
- Inverter chargers
- Custom cut cables
- Custom kits
- Batteries
- Solar panels

Please visit our web site: [www.aimscorp.net](http://www.aimscorp.net)

### **Product Registration Instructions**

Please visit our website at [www.AIMSCorp.net](http://www.AIMSCorp.net) and click on the product registration link at the top of the page.

This will validate your warranty with AIMS Power and ensure that you get fast, expedited customer service if you need to repair or exchange your product.



To find out where to buy any of our products, you may also e-mail: [sales@aimscorp.net](mailto:sales@aimscorp.net) or call (775)359-6703.

# Appendix 1 - PICOGLF Series Spec Sheet

|

## Appendix 2 - Circuit Schematics

### Circuitry scheme for models without automatic ground to neutral connection

#### Inverter Mode

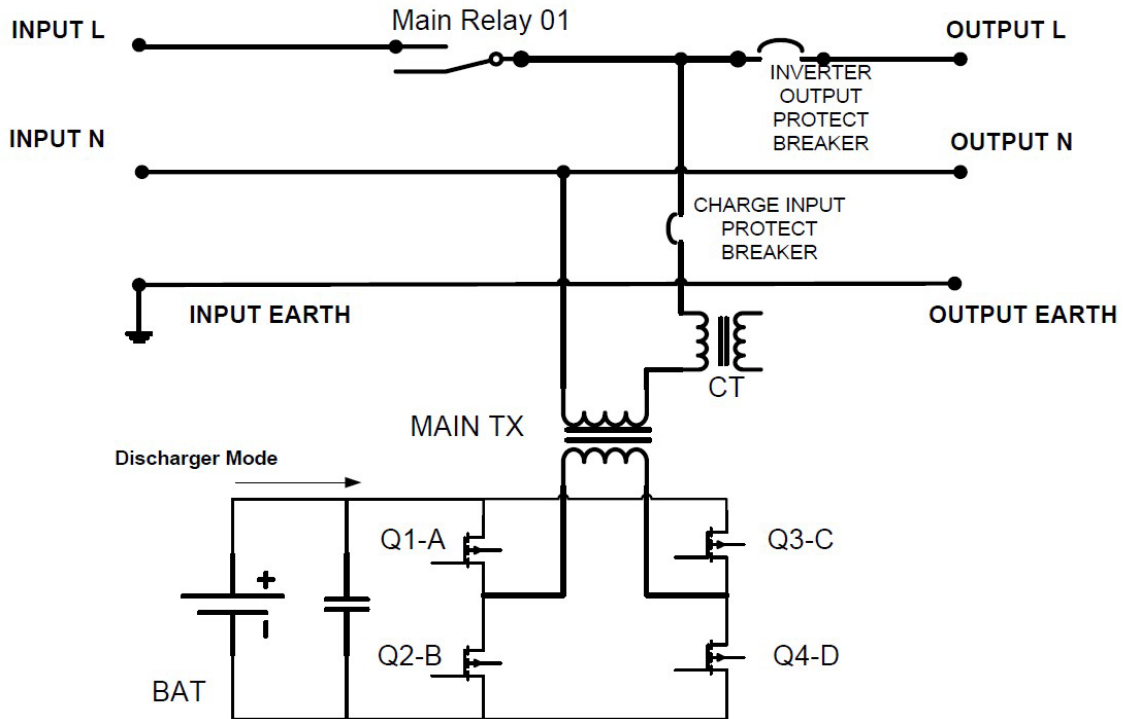

Figure 31

#### AC Mode

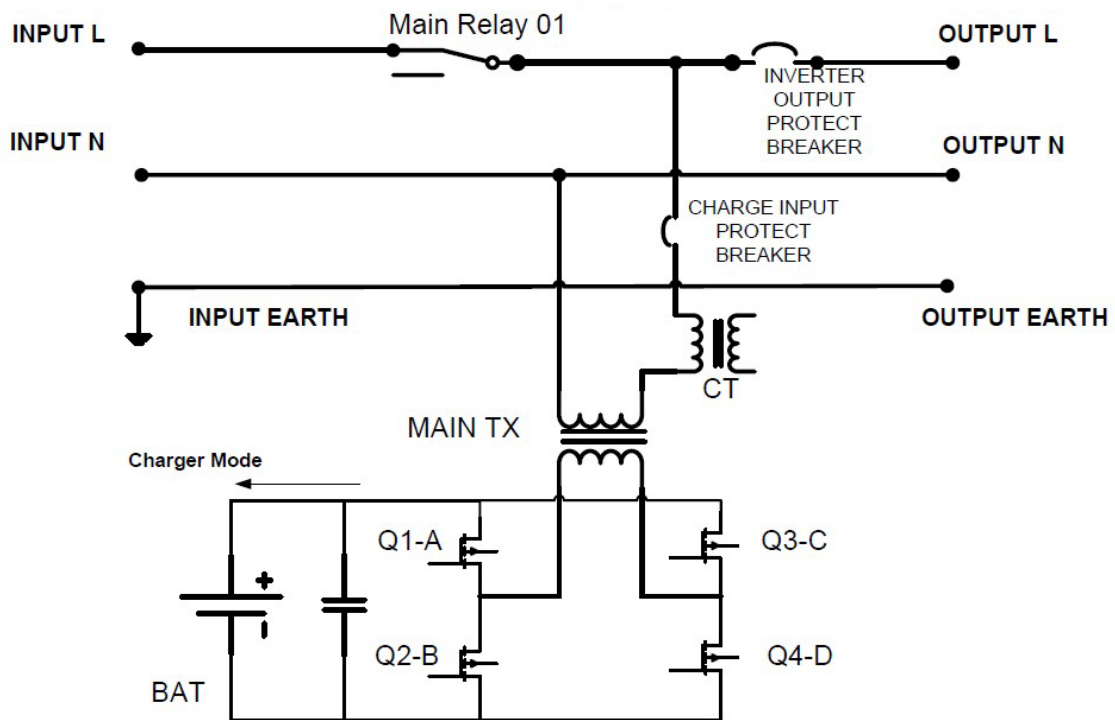

Figure 32

# Circuitry scheme for models with automatic ground to neutral connection

## Inverter Mode

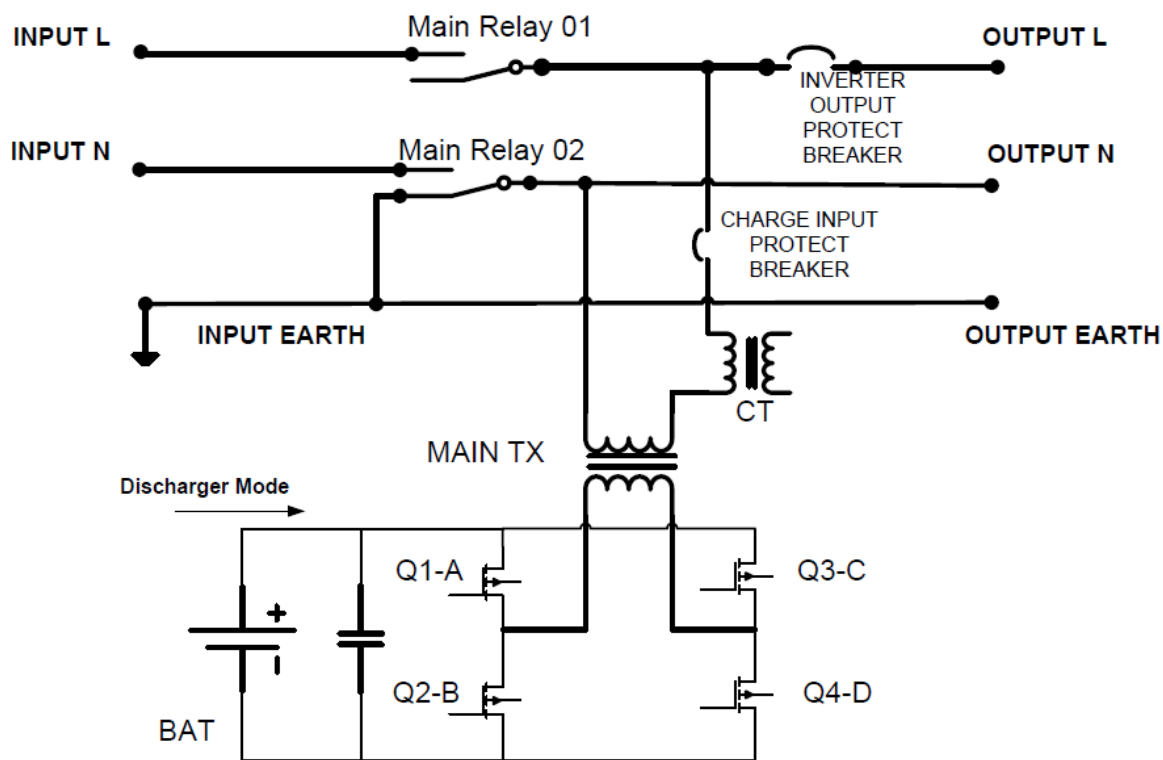

Figure 33

## AC Mode

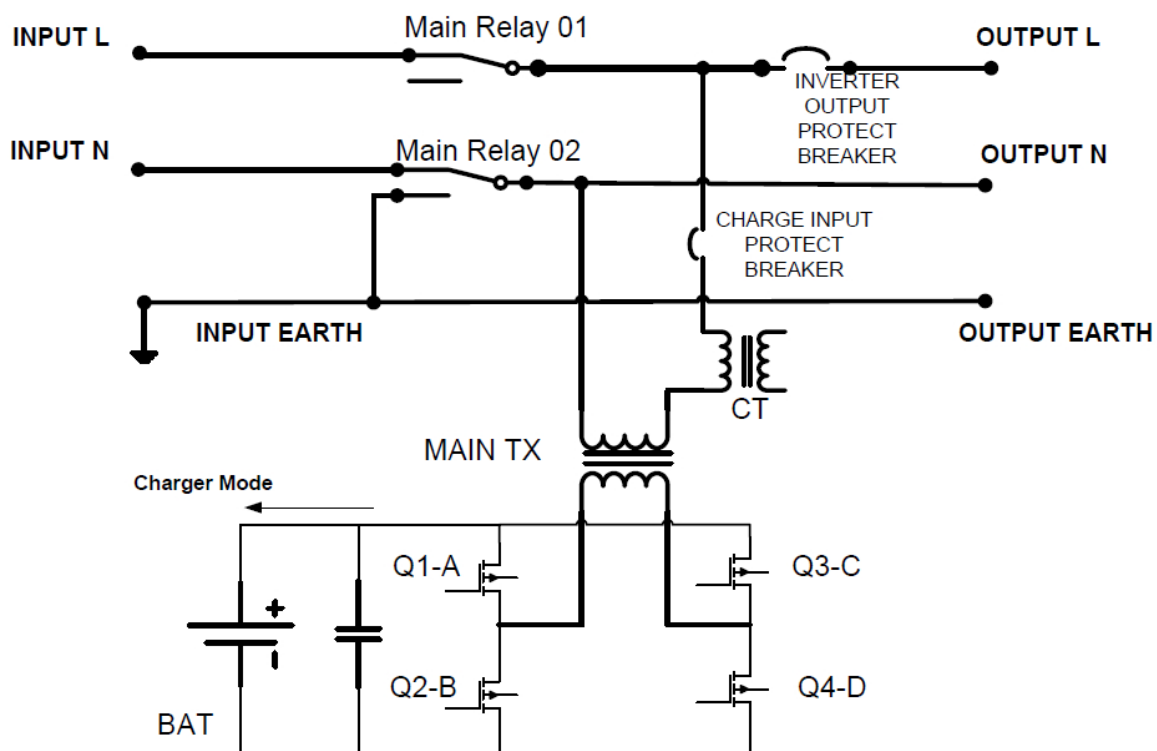

Figure 34

# Circuitry diagram for models with automatic ground to neutral connection

## Inverter Mode For PICOGLF3K12050BY

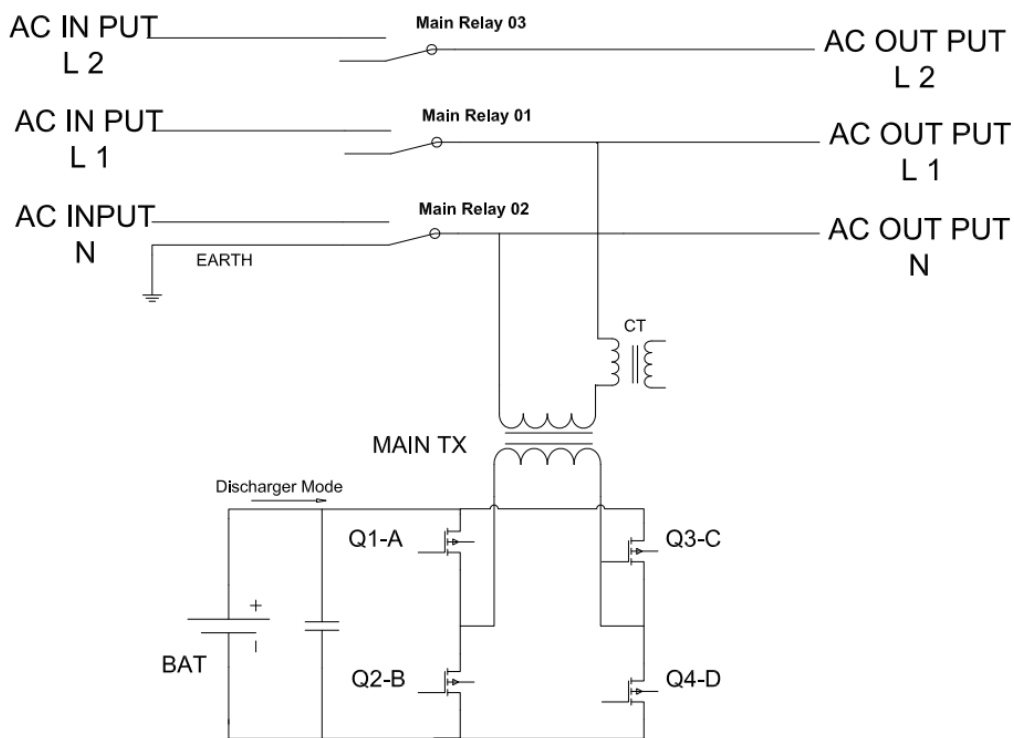

Figure 33-1

## AC Mode For PICOGLF3K12050BY

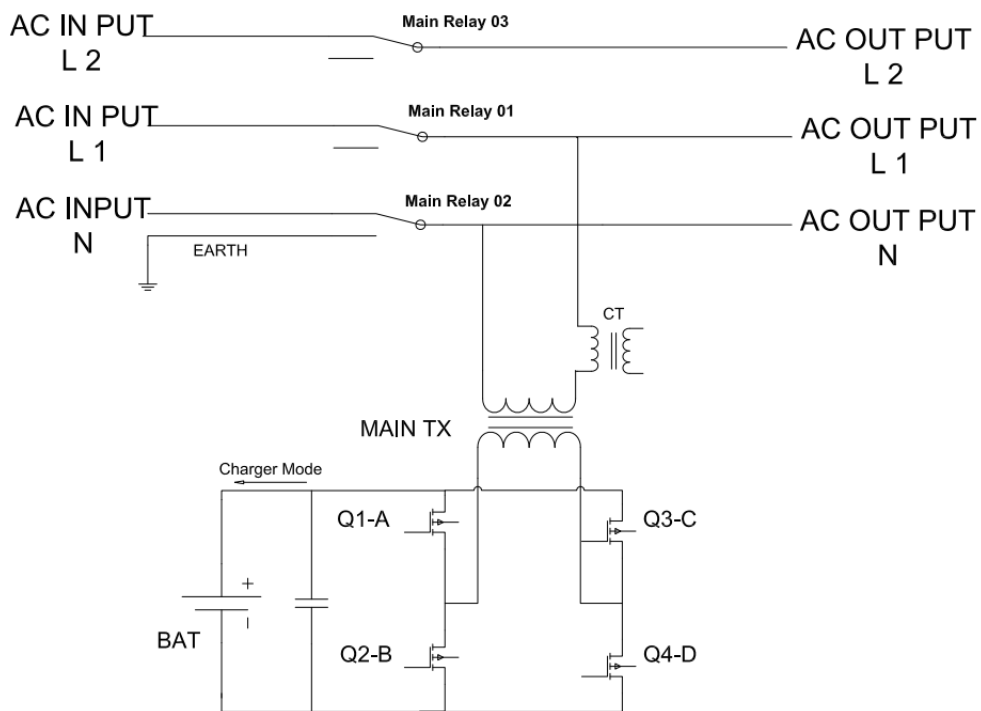
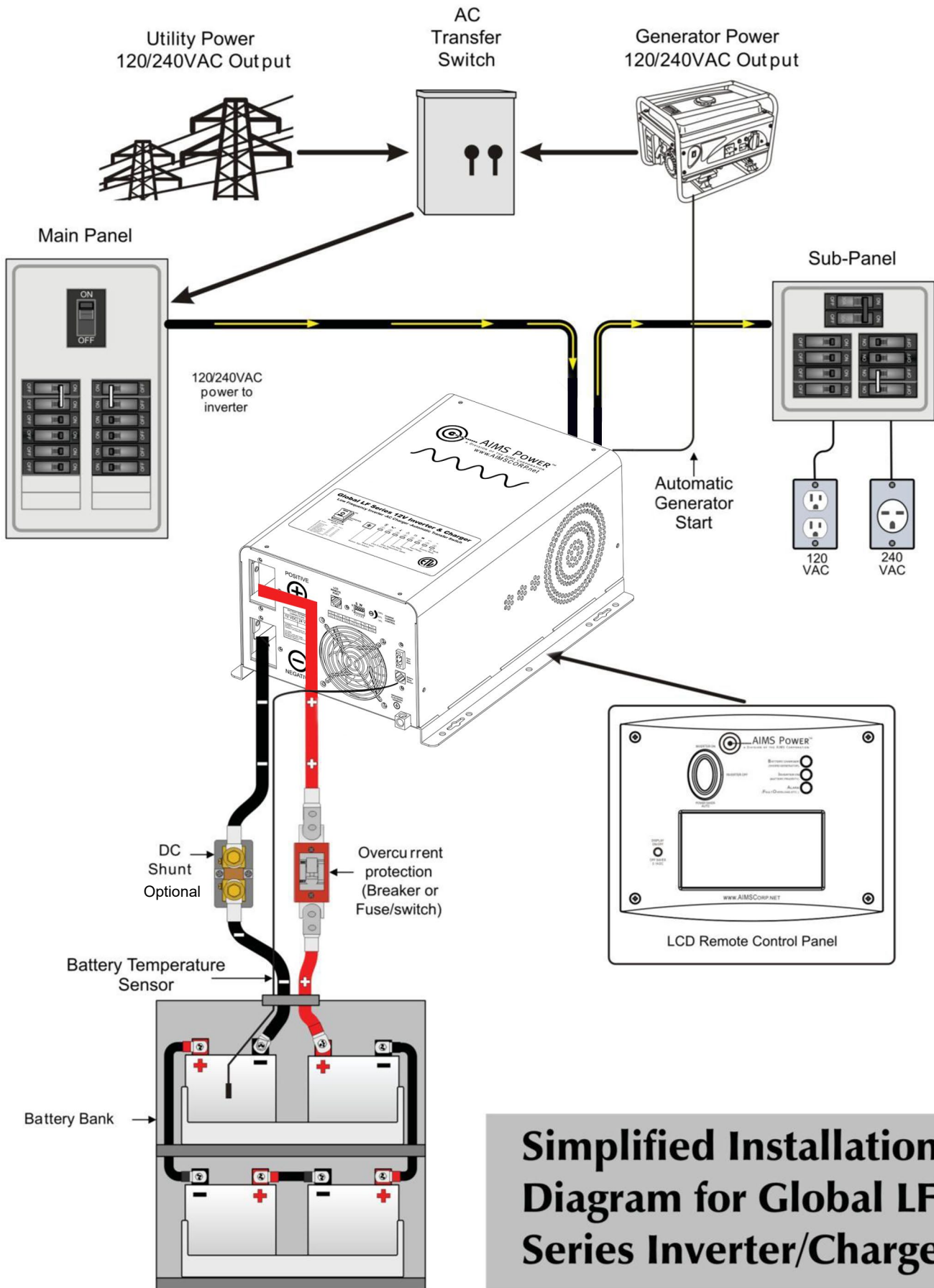

Figure 34-1



## Appendix 3 - Installation Diagram



**Simplified Installation  
Diagram for Global LF  
Series Inverter/Charger**

Figure 35

## Appendix 4 - Inverter Efficiency

The efficiency varies on different models, loads, environment and temperature.  
For more technical info of our inverters, please contact us: [techsupport@aimscorp.net](mailto:techsupport@aimscorp.net) or (775)359-6703.

✘Errors and omissions reserved. Specifications in this manual are subject to change without prior notice.



**AIMS Power, Inc.**  
**9550 GATEWAY DRIVE**  
**RENO, NV 89521**  
**TEL: (775) 359-6703**  
**FAX: (775) 359-6753**  
**WWW.AIMSCORP.NET**

**614-00040-01 / UPDATED IN 3/4/22)**

<b>INVERTER OUTPUT</b>	Continuous Output Power	3000 Watts / 3KW	
	Surge Rating (20 secs)	9000 Watts / 9KW	
	Starting Electric Motor (HP)	3 HP	
	Output Waveform	Pure Sine	
	Nominal Efficiency	>92% (Peak)	
	Line Mode Efficiency	>95%	
	Power Factor	.9 - 1	
	Nominal Output Voltage (rms)	120Vac	
	Output Voltage Regulation	± 10% RMS	
	Output Frequency	50/60 Hz ±0.3Hz	
	Short Circuit Protection	YES. Current Limit Function (fault after 1 sec)	
	Typical Transfer Time	10ms (MAX)	
	Max THD @ Full Linear Load	<20%	
	<b>DC INPUT</b>	Nominal Input Voltage	12 Vdc
Minimum Start Voltage		10Vdc	
Low Battery Alarm		10.5Vdc / 11.Vdc	
Low Battery Trip		10Vdc / 10.5Vdc	
High Voltage Alarm & Fault		16Vdc	
High DC Input Recovery		15.5Vdc	
Low Battery Voltage Recover		13Vdc	
Sleep Mode Threshold		>50 Watts (Power Saven On)	
<b>CHARGE</b>	Input Voltage Range	Narrow: 100-135Vac Wide: 90-135Vac	
	Input Frequency Range	Narrow: 47-55 ±0.3Hz @ 50Hz, 57-65 ±0.3Hz @ 60Hz	
	Output Voltage	Depends on battery type	
	Charger Breaker Rating (120 Vac)	30A	
	Max Charge Rate	100A	
	Over Charge Protection Shutdown	15.7V	
	Battery Type	<b>Fast Vdc</b>	<b>Float Vdc</b>
	Gel USA	14	13.7
	AGM 1	14.1	13.4
	AGM 2	14.6	13.7
	Sealed Lead Acid	14.4	13.6
	Gel Euro	14.4	13.8
	Open Lead Acid	14.8	13.3
	Lithium	14.4	
	De-sulphation	15.5 for 4 hours	
Battery Temp Sensor	YES. Part # PICGLFBATS		

<b>BYPASS &amp; PROTECTION</b>	Input Voltage Waveform	Pure sine from grid or generator
	Nominal Voltage	120Vac
	Low Voltage Trip	80V/100V $\pm$ 4%
	Low Voltage Re-engage	90V/100V $\pm$ 4%
	High Voltage Trip	140V $\pm$ 4%
	High Voltage Re-engage	135V $\pm$ 4%
	Max Input AC Voltage	150Vac
	Nominal Input Frequency	50Hz or 60Hz (auto detect)
	Low Freq Trip	Narrow: 47 $\pm$ 0.3Hz @ 50Hz, 57 $\pm$ 0.3Hz @ 60Hz Wide: 40 $\pm$ 0.3Hz for 50/60Hz
	Low Freq Re-engage	Narrow: 48 $\pm$ 0.3Hz @ 50Hz, 58 $\pm$ 0.3Hz @ 60Hz Wide: 45 $\pm$ 0.3Hz for 50/60Hz
	High Freq Trip	Narrow: 55 $\pm$ 0.3Hz @ 50Hz, 65 $\pm$ 0.3Hz @ 60Hz Wide: No limit for 50/60Hz
	High Freq Re-engage	Narrow: 54 $\pm$ 0.3Hz @ 50Hz, 64 $\pm$ 0.3Hz @ 60Hz Wide: No limit for 50/60Hz
	Output Short Circuit Protection	Circuit Breaker
	Bypass Breaker Rating (120 Vac)	50A
Bypass Breaker Rating (240 Vac)	50A	
GFCI Rating	20A	
<b>MECHANICAL</b>	Mounting	Predrilled holes for wall/ground
	Dimensions	16.25"L x 11"W x 7"H
	Weight	58 lb
	Shipping Dimensions	21"H x 14"W x 12"H
	Shipping Weight	67 lb
	Displays	Status LEDs/Optional LCD Remote
	Warranty	2 Year