



Find Your Energy Freedom™

# REGO

## Lithium Iron Phosphate Battery

12V | 400Ah

VERSION A0

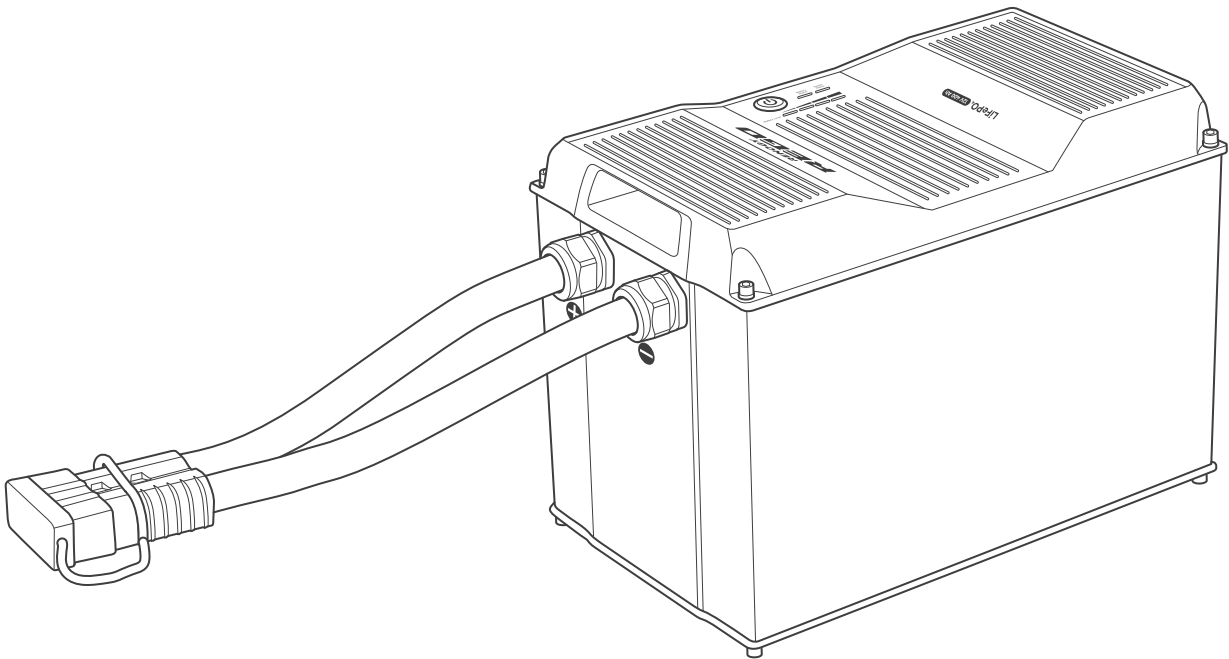

# USER MANUAL

## Applicability

The user manual applies to the following product:

- REGO 12V 400Ah Lithium Iron Phosphate Battery (RBT12400LFPL-SHBT)

## Disclaimer

- Renogy makes no warranty as to the accuracy, sufficiency, or suitability of information in the user manual because continuous product improvements are going to be made.
- Renogy assumes no responsibility or liability for losses or damages, whether direct, indirect, consequential, or incidental, which might arise out of the use of information in the user manual.
- Renogy is not responsible or liable for the failures, damages, or injuries resulting from repair attempted by unqualified personnel or improper installation and operation.
- The illustrations in the user manual are for demonstration purposes only. Details may appear slightly different depending on product revision and market region.
- Renogy reserves the right to change the information in the user manual without notice.

## Copyright

REGO 12V 400Ah Lithium Iron Phosphate Battery User Manual © 2022 Renogy. All rights reserved.

All information in the User Manual is subject to copyright and other intellectual property rights of Renogy and its licensors. The User Manual may not be modified, reproduced, or copied, in whole or in part, without the prior written permissions of Renogy and its licensors.

## Trademarks

The following are trademarks or registered trademarks of Renogy in the United States and other countries and regions:

|        |               |             |                        |
|--------|---------------|-------------|------------------------|
| RENOGY | <b>RENOGY</b> | RENOGY REGO | <b>RENOGY<br/>REGO</b> |
|--------|---------------|-------------|------------------------|

All other trademarks in the user manual are the property of their respective owners and their use herein does not imply sponsorship or endorsement of their products or services. The unauthorized use of any trademark displayed in the user manual or on the product is strictly prohibited.

## Date and Revision

June 2022, Revision A0

# Table of Contents

|                                       |    |
|---------------------------------------|----|
| Important Safety Information .....    | 05 |
| Symbols Used .....                    | 05 |
| General Safety Information .....      | 05 |
| Introduction.....                     | 07 |
| Introduction .....                    | 07 |
| Key Features .....                    | 07 |
| Package Contents .....                | 09 |
| Product Overview .....                | 10 |
| Wiring Diagram.....                   | 11 |
| Using Combiner Boxes .....            | 11 |
| Using Busbars .....                   | 11 |
| Installation .....                    | 12 |
| Inspection .....                      | 12 |
| Environment.....                      | 12 |
| Placement .....                       | 12 |
| Mounting .....                        | 13 |
| Power Connection .....                | 15 |
| Using Combiner Boxes .....            | 15 |
| Using Busbars .....                   | 18 |
| Communication.....                    | 20 |
| Inter-Device Communication.....       | 20 |
| Monitoring Device Communication ..... | 23 |
| Commission.....                       | 27 |
| Indicator Pattern .....               | 27 |
| Turning On .....                      | 27 |
| Checking Battery Level .....          | 29 |

|  |    |
|--|----|
| Checking Battery Status.....               | 30 |
| Checking Heater Status .....               | 31 |
| Changing Heater Settings .....             | 33 |
| Charging.....                              | 34 |
| Discharging .....                          | 35 |
| Turning Off .....                          | 35 |
| Maintenance .....                          | 37 |
| Inspection.....                            | 37 |
| Cleaning .....                             | 37 |
| Storage.....                               | 37 |
| Battery Management System .....            | 39 |
| Warning/Protection/Permanent Failure ..... | 39 |
| Charge Current Request .....               | 42 |
| Cell Voltage Balancing .....               | 42 |
| Troubleshooting .....                      | 43 |
| Emergency Responses .....                  | 52 |
| Fire .....                                 | 52 |
| Flooding .....                             | 52 |
| Smell .....                                | 52 |
| Technical Support.....                     | 53 |
| Technical Specifications .....             | 54 |
| Dimensions.....                            | 56 |

# Important Safety Information





Symbols Used

General Safety Information

The User Manual provides important installation, operation, and maintenance instructions for REGO 12V 400Ah Lithium Iron Phosphate Battery. Please read the User Manual carefully before installation and operation and save it for future reference. Failure to observe the instructions or precautions in the User Manual can result in electrical shock, serious injury, or death, or can damage the battery, potentially rendering it inoperable.

## Symbols Used

The following symbols are used throughout the User Manual to highlight important information:

|  |                |  |
|--|----------------|--|
|   | <b>WARNING</b> | Indicates a potentially dangerous condition which could result in injury or death.       |
|   | <b>CAUTION</b> | Indicates a critical procedure for safe and proper installation and operation.           |
|   | <b>NOTE</b>    | Indicates an important step or tip for optimal performance.                              |
|  | <b>INFO</b>    | Indicates that more information is available in other documents relating to the subject. |

## General Safety Information



### WARNING

- DO NOT puncture, drop, crush, penetrate, shake, strike, or step on the battery.
- DO NOT open, dismantle, repair, tamper with, or modify the battery.
- DO NOT touch the connector contacts of the battery.
- Please remove all connections and turn the battery off before maintenance or cleaning.
- Please install the battery in accordance with the regulations at the site of installation.
- DO NOT expose the battery to direct flame.
- Please keep the battery away from flammable or combustible materials.
- DO NOT expose the battery to harsh chemicals or vapors.
- Please keep the battery away from heating equipment.
- DO NOT touch the exposed electrolyte or powder if the battery is damaged.
- DO NOT use the battery with life support equipment or other medical equipment.
- Please keep the battery out of the reach of young children and animals.
- Please use insulated tools when working on or around the battery.
- DO NOT wear jewelry or other metal objects when working on or around the battery.
- Please wear proper protective equipment when working on or around the battery.

# Important Safety Information

Symbols Used

General Safety Information



## CAUTION

- Ensure adequate and secure mounting of the battery.
- DO NOT expose the battery to strong electrostatic fields, strong magnetic fields, or radiation.
- Please use suitable handling equipment for safe transportation of the battery.
- Ensure that no water sources are above or near the battery, including downspouts, sprinklers, or faucets.
- Ensure that snow does not accumulate around the battery.
- DO NOT lean on, stack anything on top of, or hang anything from the battery or from cables leading to the battery.

## Introduction

Meet the next era of energy storage system with Renogy 12V 400Ah REGO Lithium Iron Phosphate Battery. With a large capacity of more than 5KWh, the battery is designed to run loads for extended periods of time. Manufactured with top grade cells, the battery provides an exceptional lifespan of more than 3800 cycles (80% DOD), a continuous discharge current up to 350A for heavy loads, and a continuous charge current up to 300A for 1.5-hour fast charging. The integrated battery cables and Anderson connector significantly simplify the wiring, reduce the risk of short circuit, misconnection, and connection failure, and allow for quick connection and disconnection. The sophisticated battery management system (BMS) offers up to 60 types of warnings and protections, enables precise cell balancing, and stores up to 150 event records. The built-in heater operates automatically at low temperatures to keep the battery charging. The straightforward LED indicators visualize the battery level, battery status, and heater status. The on-board Bluetooth module ensures real-time monitoring on DC Home app and compatible monitoring devices. The RV-C protocol compatibility allows for complete system integration, featuring better charging experience, safer operation, and more customizable settings to extend the lifespan of the battery. The waterproof die cast aluminum housing and stringent road load tests ensure that the battery can deliver extreme performance even under the harshest conditions including wet environments and mechanical vibrations.

## Key Features

- **Large Capacity**

Runs loads for extended periods of time with a capacity of more than 5KWh.

- **Uncompromising Quality**

Provides an exceptional lifespan of more than 3800 cycles (80% DOD), a continuous discharge current up to 350A, and a continuous charge current up to 300A.

- **Easy Installation**

Makes wiring simple and safe with the integrated battery cables and Anderson connector.

- **Advanced BMS**

Offers comprehensive protection, precise balancing, and event logging capability with the state-of-the-art battery management system (BMS).

- **Built-In Heater**

Warms the battery up automatically at low temperatures for continuous charging with the built-in heater.

- **Visualized Status**

Visualizes the battery level, battery status, and heater status with the straightforward LED indicators.

- **Remote Monitoring**

Ensures real-time monitoring on DC Home app and compatible monitoring devices with the on-board Bluetooth module.

# Introduction

Introduction

Key Features

- **RV-C Compatible**

Allows for complete system integration for better charging experience, safer operation, and more customizable settings with the RV-C protocol compatibility.

- **Reliable Design**

Delivers extreme performance even under the harshest conditions with the waterproof die cast aluminum housing.

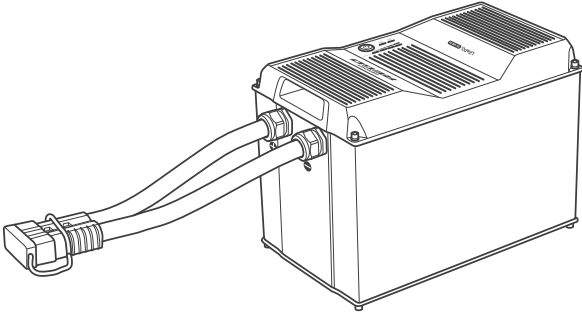
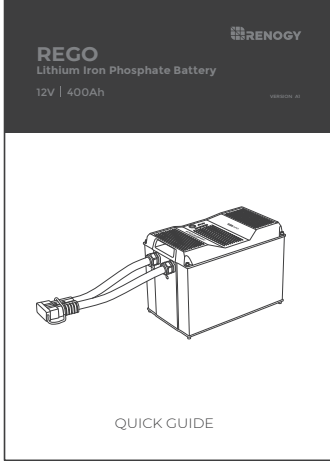

# Package Contents

| 12V 400Ah REGO Lithium Iron Phosphate Battery × 1                                 | Quick Guide × 1  |
|---|--|
|  |  |

# Product Overview

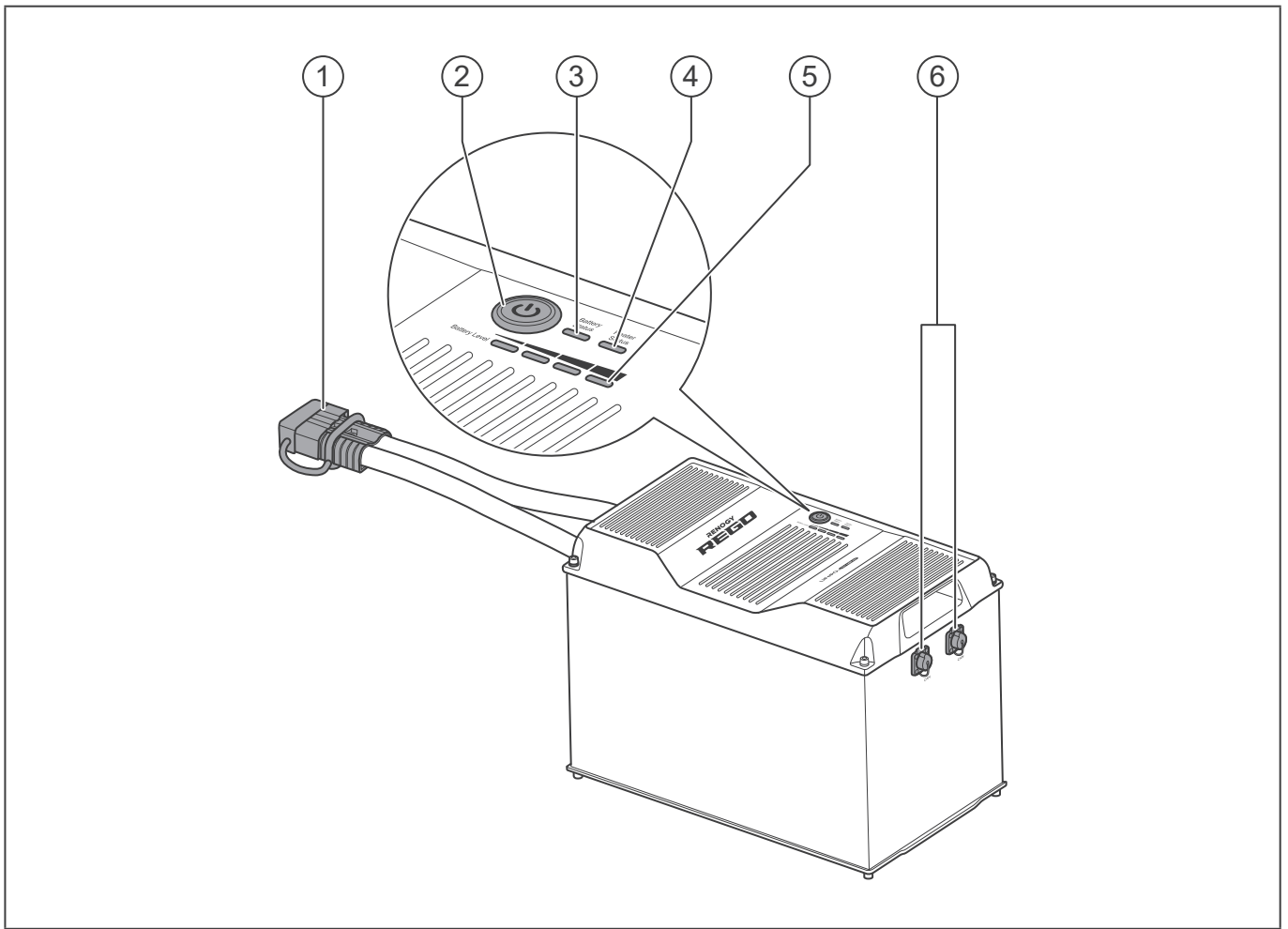

| No. | Part  | No. | Part                    |
|-----|---|-----|-------------------------|
| 1   | Gray Anderson 350 Connector (with Dust Cover) | 4   | Heater Status Indicator |
| 2   | Power Button                                  | 5   | Battery Level Indicator |
| 3   | Battery Status Indicator                      | 6   | CAN Communication Ports |

# Wiring Diagram

Using Combiner Boxes

Using Busbars

## Using Combiner Boxes

Single Battery

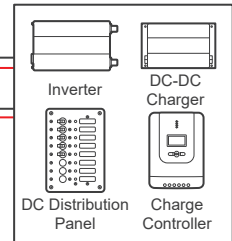
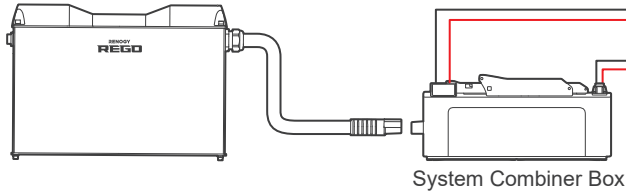

Multiple Batteries

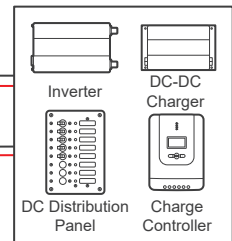
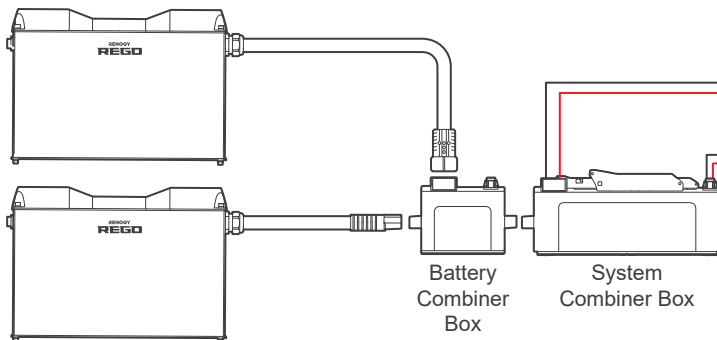

— Positive — Negative

## Using Busbars

Single Battery

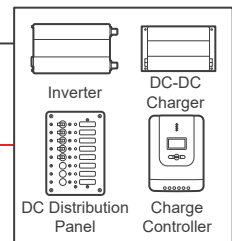
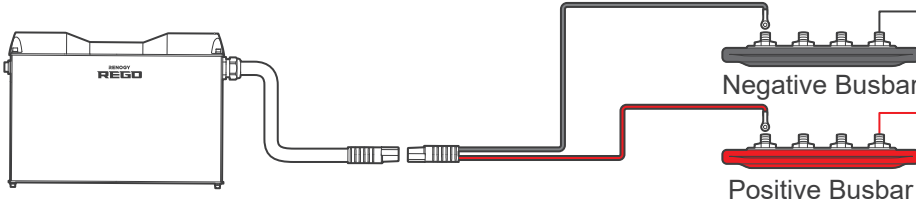

Multiple Batteries

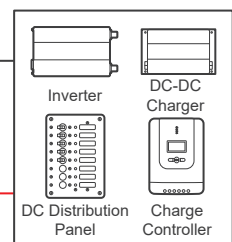
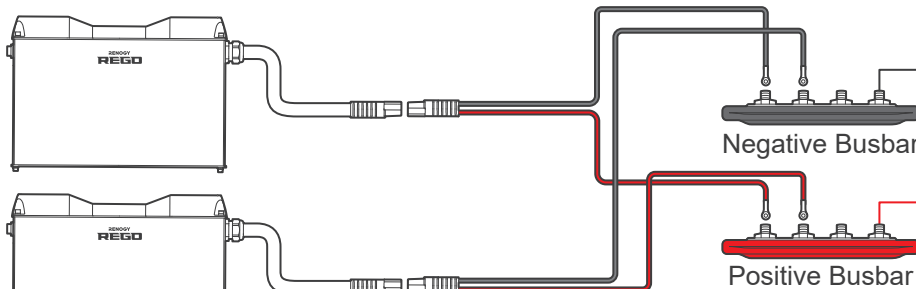

— Positive — Negative

# Installation

Inspection

Environment

Placement

Mounting

## Inspection

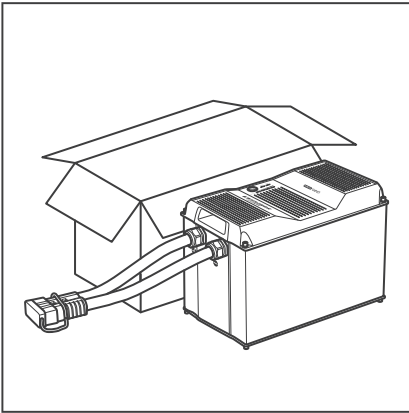

Inspect the battery for any visible damages including cracks, dents, deformation, and other visible abnormalities before installation. The connector contacts shall be dry, clean, and free of any dirt and corrosion.



### WARNING

- DO NOT use the battery if it appears damaged.

## Environment

Ensure that the installation environment is clean, cool, and well-ventilated. Keep the battery away from oil and dirt. The accumulation of these substances can cause current leakage, resulting in self-discharge and a possible short circuit. Avoid restricting airflow by tightly packing batteries together. Allow at least 0.5 inches (12.7 mm) of space between the batteries for efficient heat dissipation and minimal battery temperature variations. Safe operation requires environment temperatures between  $-4^{\circ}\text{F}$  ( $-20^{\circ}\text{C}$ ) and  $122^{\circ}\text{F}$  ( $50^{\circ}\text{C}$ ). The recommended operating environment temperature range is  $59^{\circ}\text{F}$  ( $15^{\circ}\text{C}$ ) and  $86^{\circ}\text{F}$  ( $30^{\circ}\text{C}$ ).

## Placement

Place the battery upright or horizontally on the long side.

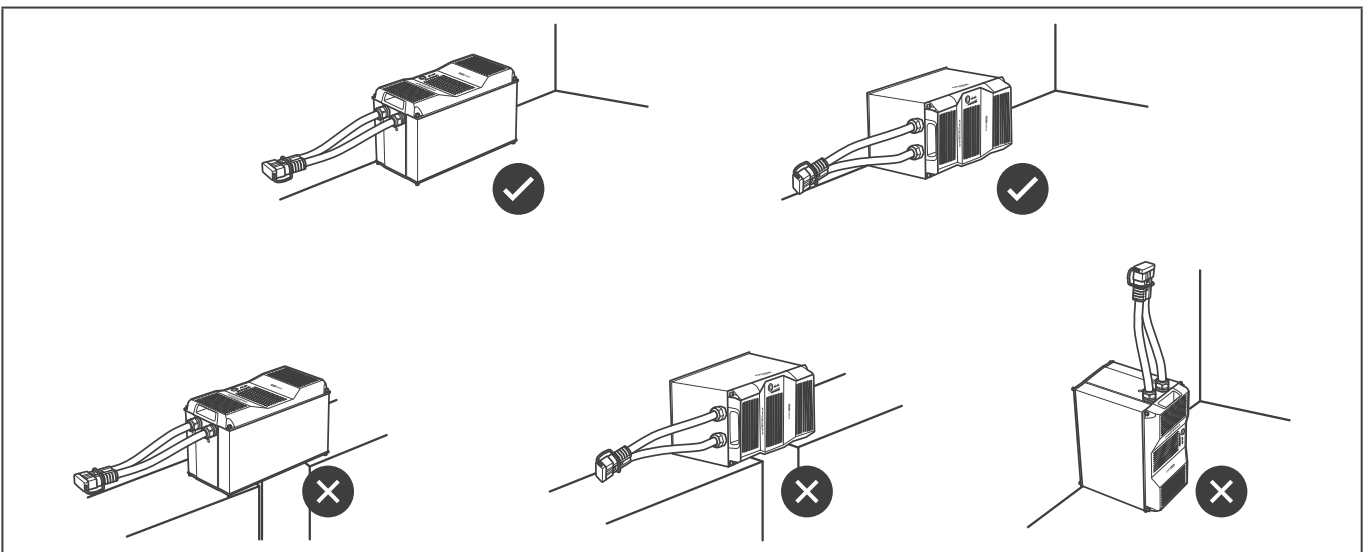

# Installation

Inspection

Environment

Placement

Mounting



## CAUTION

- DO NOT place the battery upside down or horizontally on the short side.
- Ensure that the battery is fully supported.

## Mounting

### Recommended Tool and Accessories

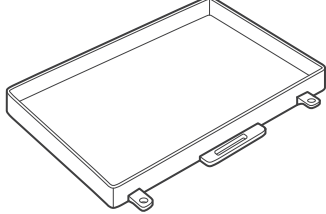
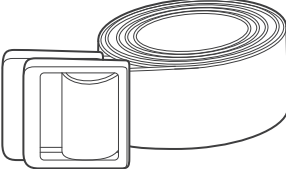
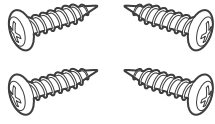
| Phillips Screwdriver  | Battery Tray  |
|---|---|
|    |     |
| Tie Down Strap  | Mounting Screws   |
|  |  |

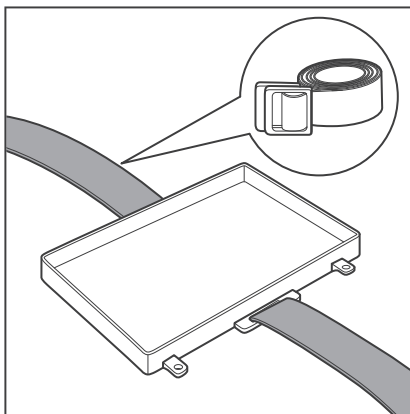

1. Thread the Tie Down Strap through the strap anchors on the Battery Tray.

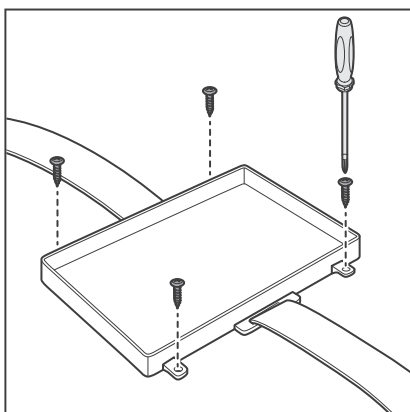

2. Secure the Battery Tray on a flat mounting surface with the Mounting Screws. Tighten the Mounting Screws with the Phillips Screwdriver.

# Installation

Inspection

Environment

Placement

Mounting

## **i** NOTE

- It is recommended to pre-drill holes on the mounting surface with a drill and a drill bit before mounting the Battery Tray.

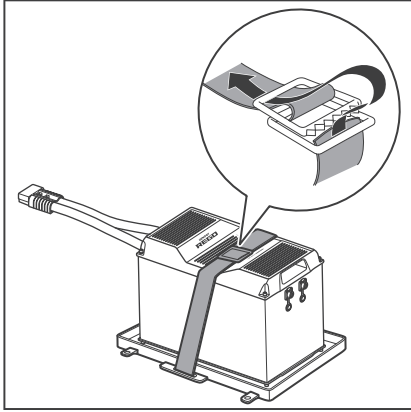

3. Place the battery into the Battery Tray. Buckle the Tie Down Strap over the battery.

## **i** NOTE

- Alternative mounting methods are allowed to meet the requirements of specific applications.

# Power Connection

Using Combiner Boxes

Using Busbars

The batteries can be connected in parallel and to the system with either combiner boxes or busbars. Parallel connection is intended to increase the battery bank capacity while keeping the battery bank voltage the same.

## WARNING

- DO NOT short the contacts of the Anderson Connector. Short circuits can damage the battery.
- DO NOT connect batteries in series. Series connection can damage the batteries.
- DO NOT mix battery brands, models, chemistries, nominal voltages, and rated capacities.

## CAUTION

- Please check the polarity before connecting the cables. Reverse polarity can damage the battery and connected devices.
- The Anderson Connectors are color coded. DO NOT mate the Anderson Connectors with different colors together.
- DO NOT connect more than 8 batteries in parallel.
- Please avoid large voltage difference between batteries connected in parallel.

## Using Combiner Boxes

Connecting the batteries in parallel and to the system using the Battery Combiner Box and the System Combiner Box significantly reduces the risk of short circuit, misconnection, or connection failure and allows for quick connection and disconnection.

### Required Accessories

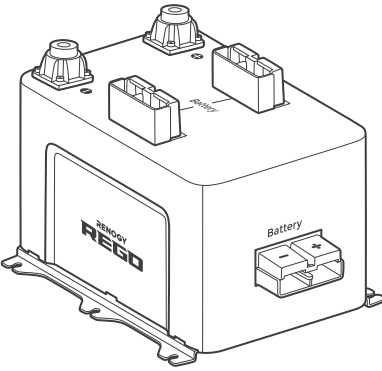
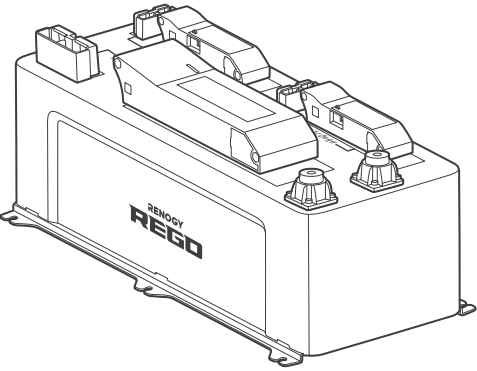
| REGO 3 Ports 400A Battery Combiner Box(es)  | REGO 4 Ports 400A System Combiner Box  |
|---|--|
|  A line drawing of a rectangular battery combiner box. It has three Anderson connectors on top and one on the front. The front connector is labeled 'Battery'. The box has 'REGO' and 'Battery' printed on it. |  A line drawing of a rectangular system combiner box. It has four Anderson connectors on top and one on the front. The box has 'REGO' printed on it. |

## INFO

- Please read the user manual of REGO 3 Ports 400A Battery Combiner Box and REGO 4 Ports 400A System Combiner Box at [renogy.com](http://renogy.com) before the connection.

# Power Connection

Using Combiner Boxes

Using Busbars

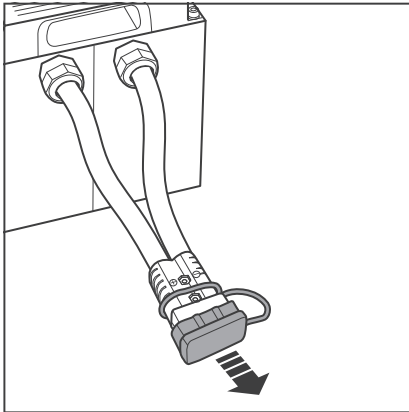

1. Remove the Dust Covers from the Anderson Connectors. If multiple batteries are to be connected in parallel, refer to [step 2](#) to [step 4](#). If only one battery is used, refer to [step 5](#).

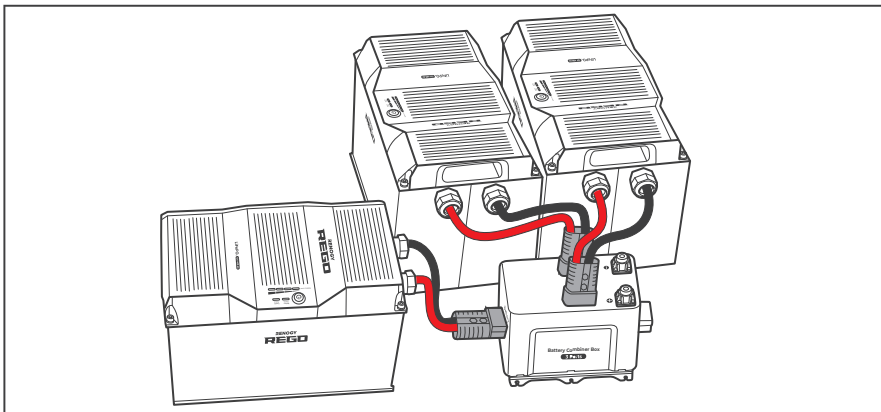

2. If multiple batteries are to be connected in parallel, plug the Anderson Connectors of the batteries to the Battery Combiner Box (sold separately).

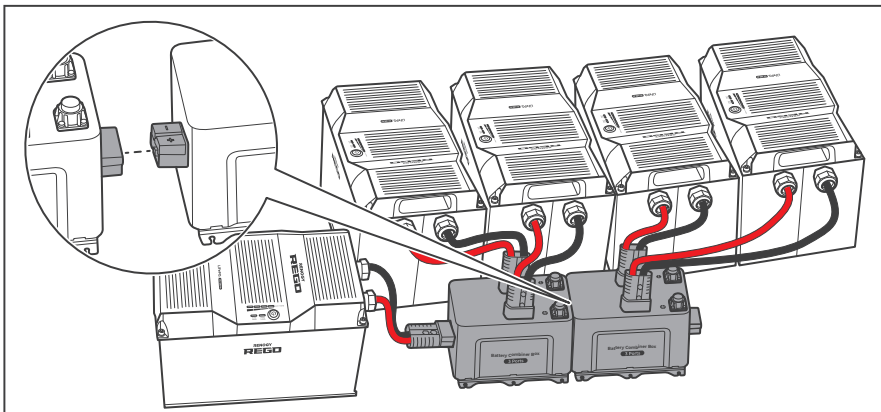

3. If necessary, connect multiple Battery Combiner Boxes together to accept more batteries in parallel.

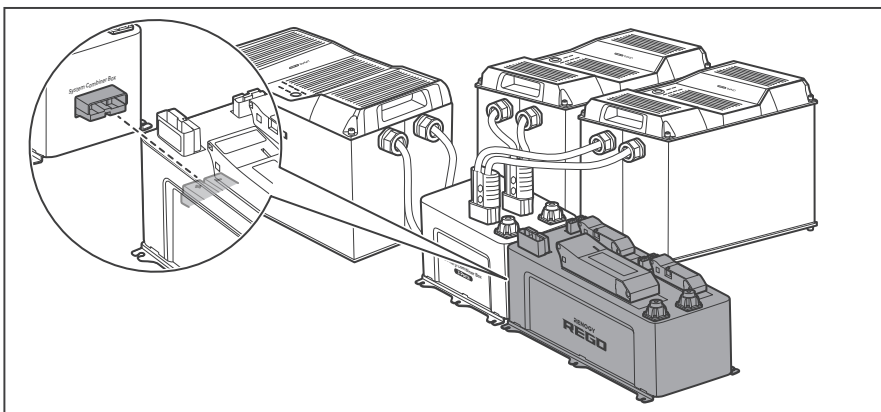

4. Connect the Battery Combiner Box and the System Combiner Box (sold separately) using the Anderson connectors on their sides.



# Power Connection

Using Combiner Boxes

Using Busbars

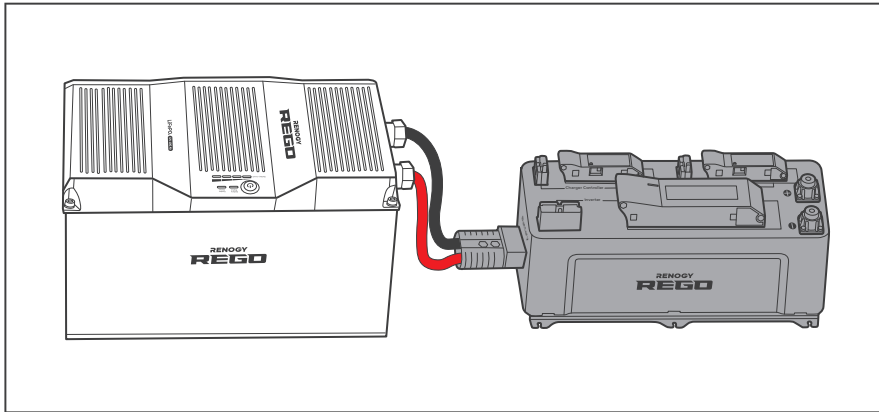

5. If only one battery is used, connect the battery directly to the Anderson connector on the side of the System Combiner Box.

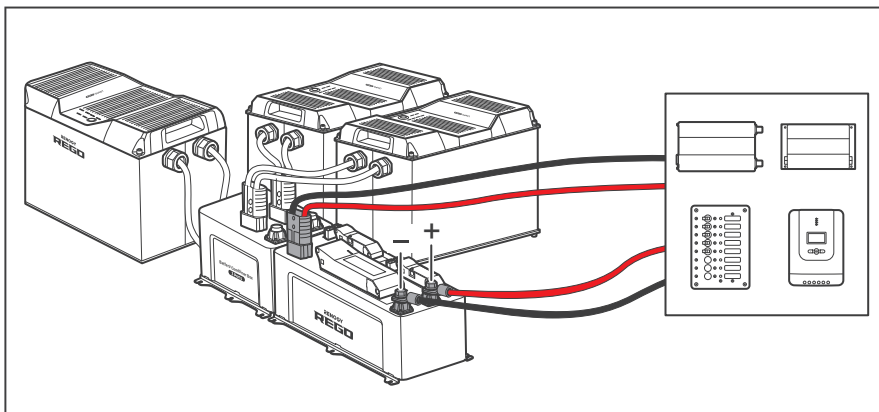

6. Connect the devices to the corresponding Anderson connectors or insert terminals on the top of the System Combiner Box.

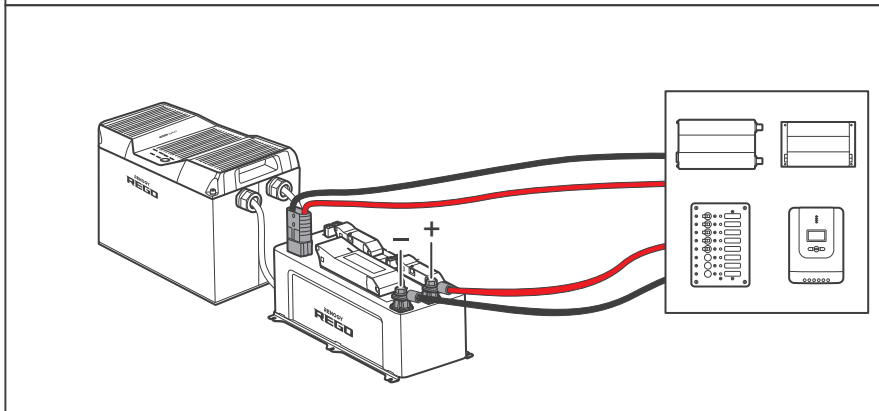

## WARNING

- Please size the device cables appropriately to handle the expected current. Refer to the user manuals of the connected devices for more instructions.
- If the devices are connected to the Anderson connectors of the System Combiner Box, please install appropriately sized NH fuses (sold separately) in the System Combiner Box to protect connected devices and circuit wires. Refer to the user manual of the REGO 4 Ports 400A System Combiner Box for more instructions.
- If the devices are connected to the insert terminals of the System Combiner Box, please install appropriately sized fuses or circuit breakers in the branch circuits to protect connected devices and circuit wires. Refer to the user manuals of the connected devices for more instructions.
- Please ensure that the Anderson Connectors are fully seated and/or the ring terminals are

# Power Connection

Using Combiner Boxes

Using Busbars

secured to the proper specification.

## Using Busbars

### Required Accessories

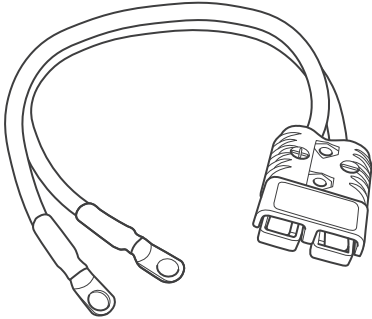
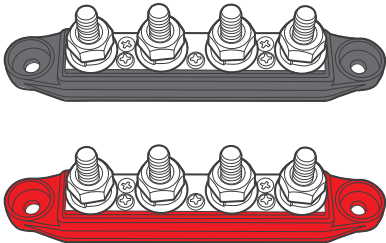
| Gray Anderson 350 Connector to Ring Terminal Adapter Cable(s)                     | Positive/Negative Busbars  |
|---|--|
|  |  |



### WARNING

- DO NOT short the positive and negative ring terminals of the Adapter Cable(s). Short circuits can damage the battery.

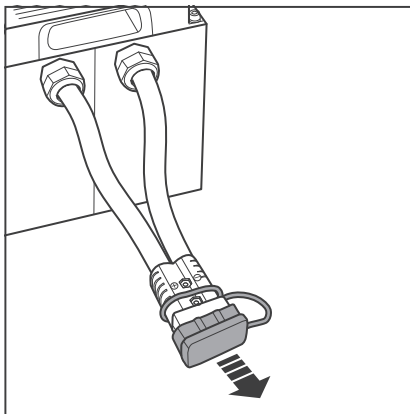

1. Remove the Dust Cover(s) from the Anderson Connector(s).

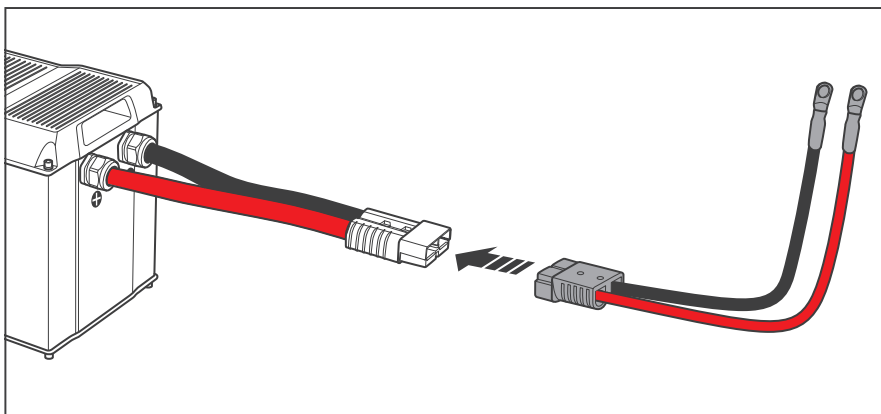

2. Connect the Anderson Connector(s) of the battery(ies) to the Adapter Cable(s) (sold separately).

# Power Connection

Using Combiner Boxes

Using Busbars

## WARNING

- Please size the Adapter Cable(s) appropriately to handle the expected current. Refer to Appendix for more instructions.

## CAUTION

- If multiple batteries are to be connected in parallel, please ensure equal length of the Adapter Cables to make the batteries operate equally together.

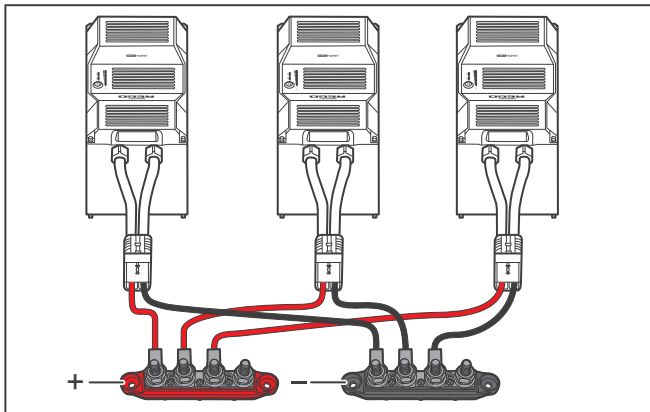

3. Connect the positive and negative ring terminals of the Adapter Cable(s) to the Positive and Negative Busbars (not included) respectively.

## WARNING

- Please size the Busbars appropriately to handle the expected current. Refer to Appendix for more instructions.

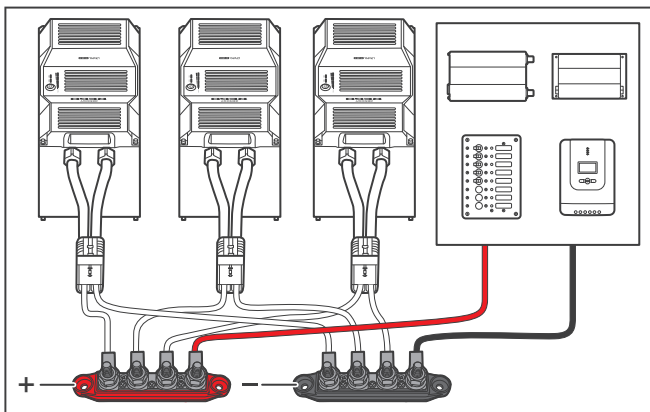

4. Connect the devices to the Positive and Negative Busbars.

## WARNING

- Please size the device cables appropriately to handle the expected current. Refer to the user manuals of the connected devices for more instructions.
- Please install appropriately sized fuses or circuit breakers in the branch circuits to protect connected devices and circuit wires. Refer to the user manuals of the connected devices for more instructions.
- Please ensure that the Anderson Connector(s) is fully seated and/or the ring terminals are secured to the proper specification.

# Communication

The communication connection is optional. It allows the battery to communicate with other REGO devices and monitoring devices, enabling safe operation, smart control, remote monitoring, and programmable settings.

## Inter-Device Communication

Depending on the installation condition, the communication connections between the battery and other REGO devices can be established with backbone or daisy chain topology. The inter-device communication allows the battery to dynamically adjust the charging profile for an optimal and safe charge.

### Backbone Topology

If an RV-C bus is pre-installed in the RV, follow the backbone topology for the inter-device communication connections.

### Required Accessories

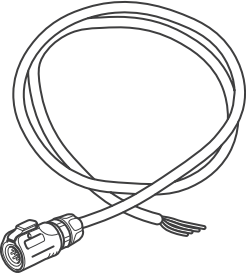
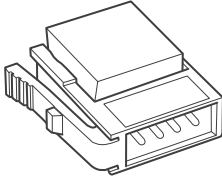
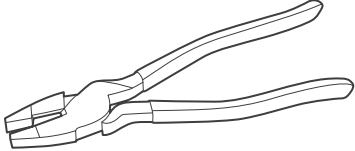
| LP16 Plug (7-Pin) to Bare Wires Drop Cables   | Drop Plugs  | Split Joint Pliers  |
|---|---|---|
|  |  |  |

### CAUTION

- The lengths of the Drop Cables shall not exceed 19.6 feet (6 m), and the total length shall not exceed 98.4 feet (30 m).

### NOTE

- Please check the network wiring diagram provided by the RV manufacturer before connection.

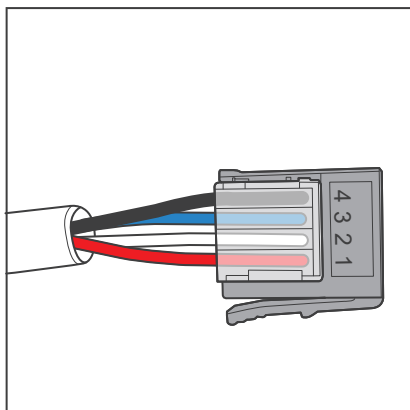

1. Insert the bare wires of the Drop Cables (sold separately) all the way into the wire ports of the Drop Plugs (not included) following the Drop Plug pinout. The red PS+ wires go to pin 1, the white CAN\_H wires go to pin 2, the blue CAN\_L wires go to pin 3, and the black PS- wires go to pin 4.

# Communication

## **i** NOTE

- Different drop sockets are used on the RV-C bus by different RV manufacturers. Please select the Drop Plugs that match the drop sockets for the inter-device communication connections. If unsure about the Drop Plug selection, please check with the RV manufacturer. This User Manual takes the Mini-Clamp II plug (4-pin) as an example.
- Different Drop Plugs follow different pinouts. Please crimp the Drop Plugs on the Drop Cables following the correct pinout. If unsure about the Drop Plug pinout, please check with the RV manufacturer. This User Manual takes the pinout of the Mini-Clamp II plug (4-Pin) as an example.

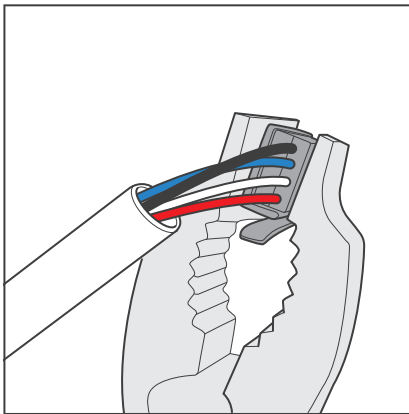

2. Squeeze the crimp areas of the Drop Plugs with the Split Joint Pliers.

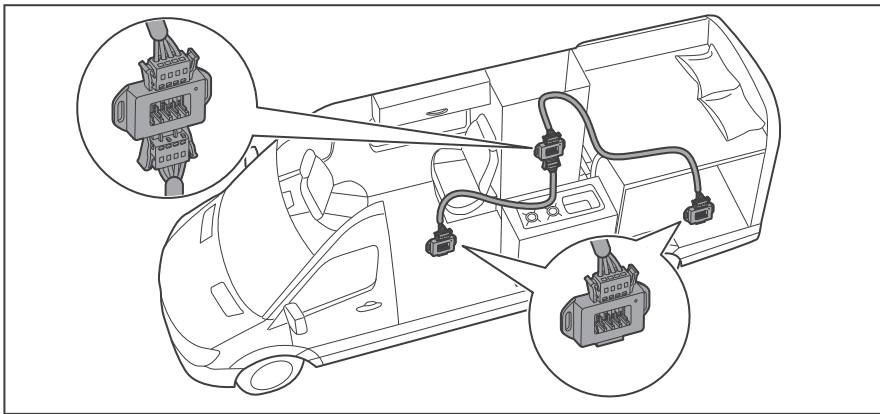

3. Locate the drop tap (not included) on the RV-C bus that is the closest to the battery installation location. The drop taps are usually located above the entry door, in the bathroom, or under the bed in the RV.

## **!** CAUTION

- Please ensure that the drop taps at both ends of the RV-C bus are properly terminated with built-in 120Ω resistors.

## **i** NOTE

- Different drop taps are used on the RV-C bus by different RV manufacturers. This User Manual takes the 4-socket drop tap as an example.
- If unable to locate the drop taps, please contact the RV manufacturer for help.

# Communication

Inter-Device Communication

Monitoring Device Communication

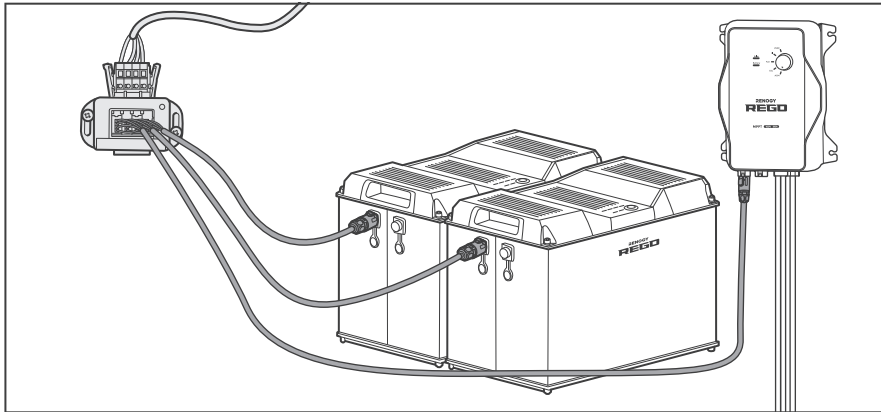

4. Connect either of the CAN Communication Ports of the battery and other REGO devices to the drop sockets on the drop tap with the Drop Cables.

## Daisy Chain topology

If the RV-C bus is not available, follow the daisy chain topology for the inter-device communication connections.

### Recommended Accessories

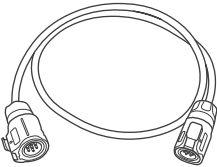
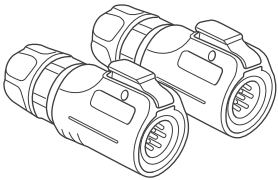
| LP16 Plug (7-Pin) Communication Cable(s)  | LP16 Terminator Plugs (7-Pin)  |
|---|--|
|  |  |

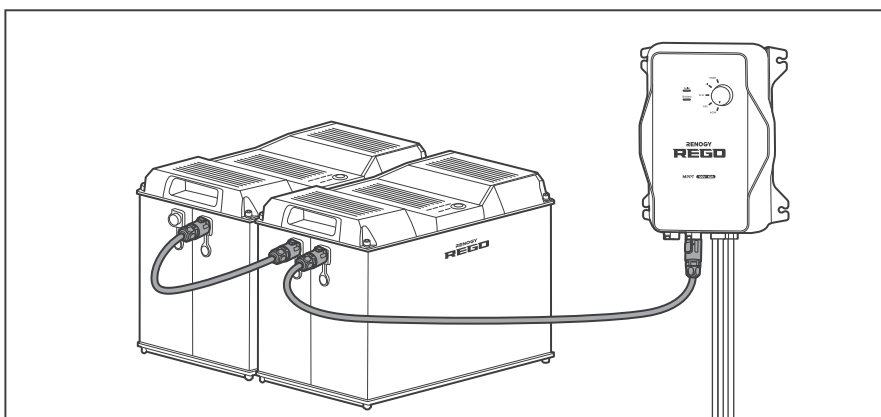

1. Connect REGO devices in series through either of the CAN Communication Ports with the Communication Cable(s) (sold separately).

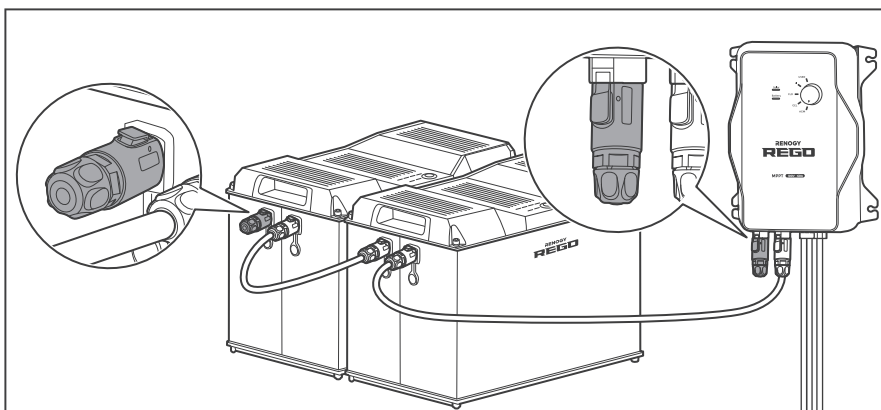

2. Plug the Terminator Plugs (sold separately) into the free CAN Communication Ports on the first and last REGO devices.

## Monitoring Device Communication

Depending on the application, the short-range or long-range communication connections can be established between the battery and the monitoring devices. The monitoring device communication allows for the monitoring and programming of the battery or even the complete system.

### **i** NOTE

- Please scan the QR code on the [last page](#) of the User Manual to download the DC Home app.
- Please make sure that the battery is turned on before the connection. Refer to the [Turning On](#) section for more instructions.

### Short-Range Monitoring

If only short-range monitoring is required, connect the battery to the DC Home app directly through Bluetooth.

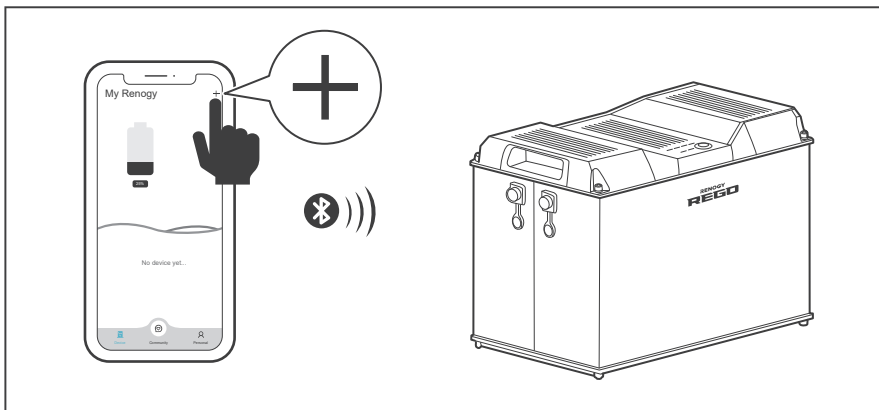

1. Open the DC Home app. Turn on the Bluetooth on the phone or tablet. Tap “+” on the top right corner to search for the battery. Wait for a few minutes until the battery is found.

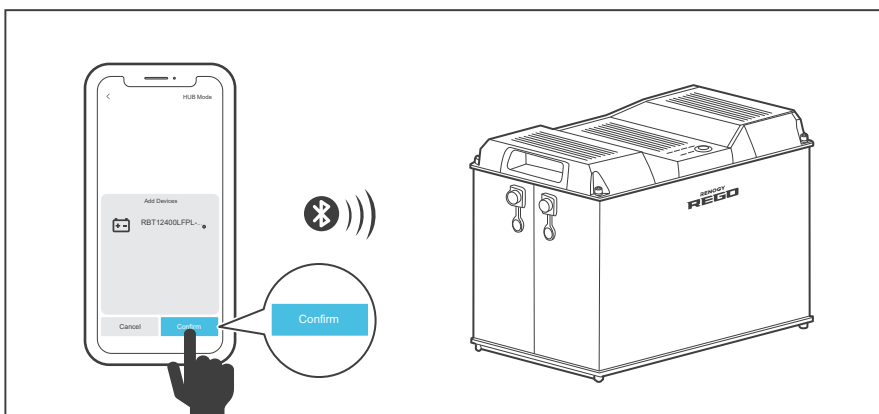

2. Tap “Confirm” on the pop-up menu to add the battery to the device list. Monitor the battery on the device page.

### **i** NOTE

- Please keep the phone or tablet within 10 feet (3 m) of the battery.

# Communication

## Long-Range Monitoring

If long-range communication and programming are required, connect the battery to Renogy ONE through Bluetooth or hard wire, and Renogy ONE to the DC Home app through WiFi.

### Required Tool and Accessories

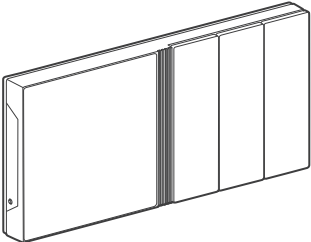
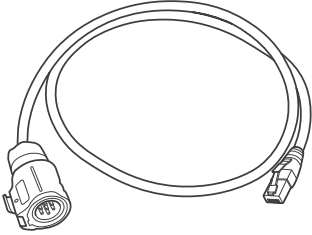
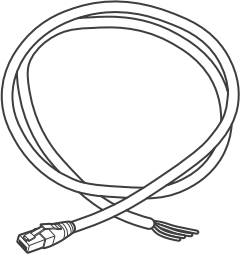
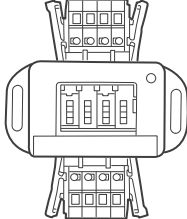
|  |  |
|--|--|
| Renogy ONE   | LP16 Plug (7-Pin) to RJ45 Communication Adapter Cable                                |
|   |    |
| RJ45 Plug to Bare Wires Drop Cable   | Common Drop Tap  |
|  |  |

### NOTE

- Please make sure Renogy ONE is powered on before the connection.

### INFO

- Please read the user manual of Renogy ONE at [renogy.com](http://renogy.com) before the connection.

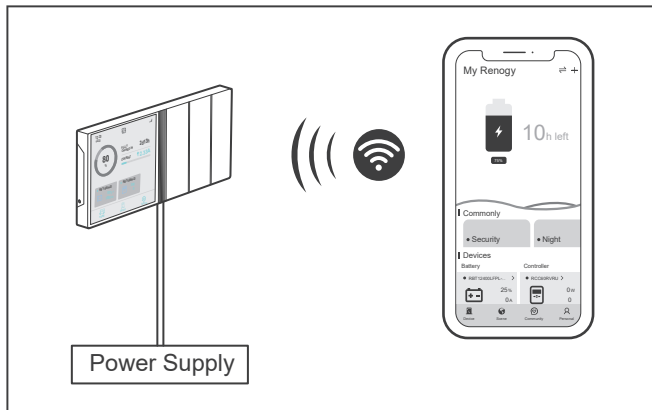

1. Pair Renogy ONE (sold separately) with the DC Home app through WiFi. If the inter-device communication is not established, refer to [step 2](#). If the inter-device communication is established with the backbone topology, refer to [step 3](#) to [step 4](#). If the inter-device communication is established with the daisy chain topology, refer to [step 5](#) to [step 6](#).



# Communication

Inter-Device Communication

Monitoring Device Communication

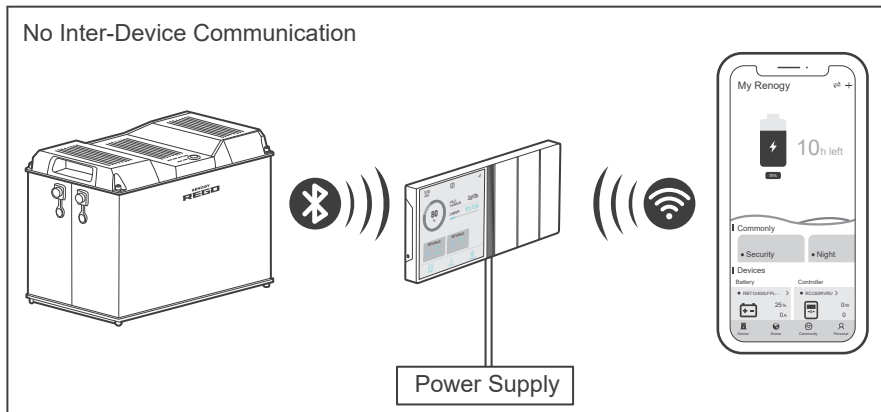

2. If the inter-device communication is not established, connect the battery to Renogy ONE through Bluetooth. Monitor the battery on Renogy ONE or the DC Home app.

## NOTE

- Please keep Renogy ONE within 10 feet (3 m) of the battery.

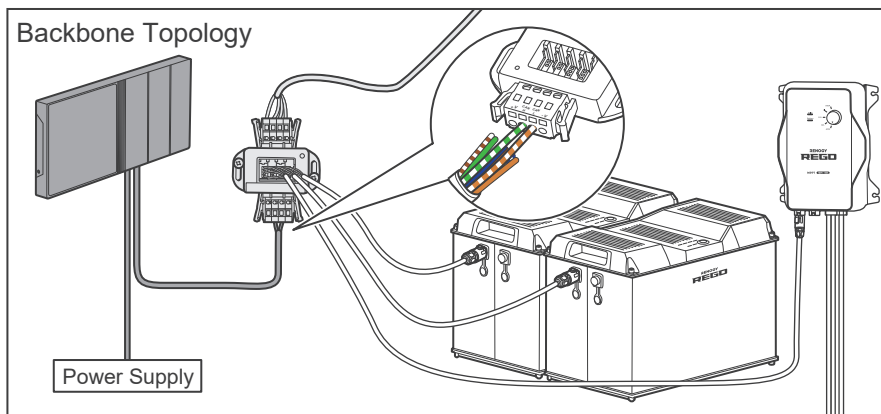

3. If the inter-device communication is established with the backbone topology, replace the terminated drop tap at either end of the RV-C bus with the Common Drop Tap (not included). Secure the bare wires of the Drop Cable (not included) onto the terminal block plug of the Common Drop Tap following the terminal block plug pinout. Plug the Drop Cable to the RJ45 port of Renogy ONE.

## NOTE

- Different terminal block plugs are used on different Common Drop Taps and follow different pinouts. Please connect the Drop Cable to the terminal block plug of the Common Drop Tap following the correct pinout. If unsure about the terminal block plug pinout, please check with the RV manufacturer. This User Manual takes the pinout of the MCS MIDI Classic terminal block plug (4-Pin) as an example.
- Please refer to the [Backbone Topology](#) section for more instructions.

# Communication

Inter-Device Communication

Monitoring Device Communication

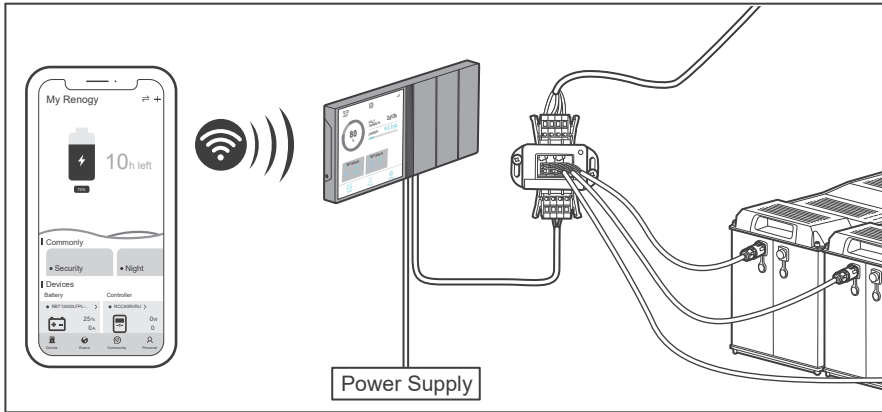

4. Monitor and program the complete system on Renogy ONE or the DC Home app.

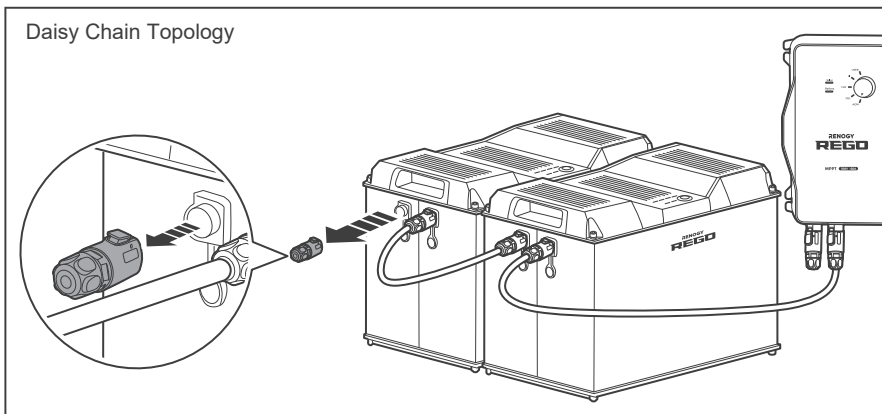

5. If the inter-device communication is established with the daisy chain topology, remove the Terminator Plug from the REGO device at either end of the daisy chain.

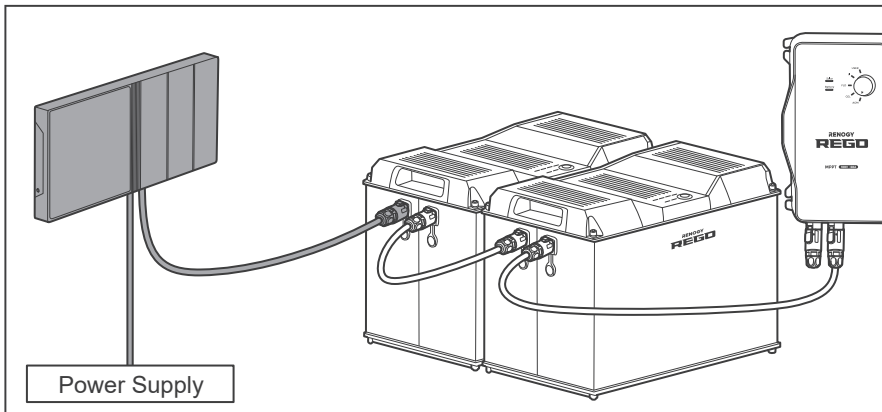

6. Connect Renogy ONE to the free CAN Communication Port on the REGO device with the Communication Adapter Cable (sold separately). Monitor and program the complete system on Renogy ONE or the DC Home app.

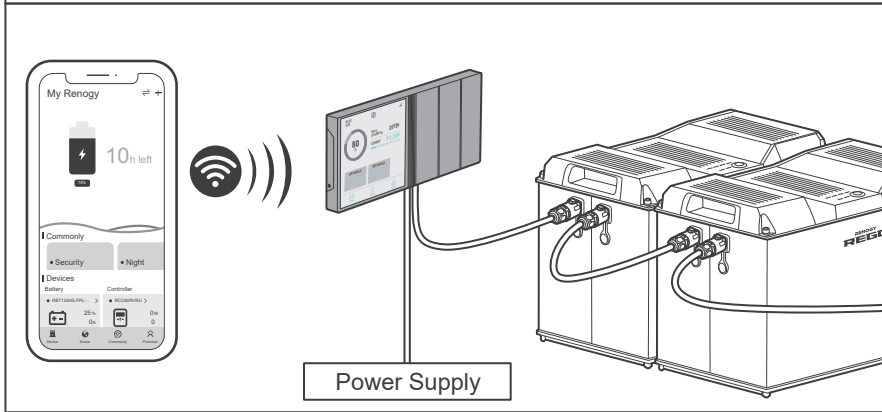

# Commission

Indicator Pattern

Turning On

Checking Battery Level

Checking Battery Status

Checking Heater Status

Changing Heater Settings

Charging

Discharging

Turning Off

## Indicator Pattern

| Indicator Pattern | 1 Second  | 1 Second  |
|-------------------|---|---|
| Solid             | [Solid Blue Bar]  | [Solid Blue Bar]  |
| Slow Flash        | [Blue Bar] [White Bar]  | [Blue Bar] [White Bar]  |
| Fast Flash        | [Blue Bar] [White Bar] [Blue Bar] [White Bar]   | [Blue Bar] [White Bar] [Blue Bar] [White Bar]   |
| Double Flash      | [Blue Bar] [White Bar] [Blue Bar] [White Bar]   | [Blue Bar] [White Bar] [Blue Bar] [White Bar]   |
| Strobe            | [Blue Bar] [White Bar] [Blue Bar] [White Bar] [Blue Bar] [White Bar] [Blue Bar] [White Bar] | [Blue Bar] [White Bar] [Blue Bar] [White Bar] [Blue Bar] [White Bar] [Blue Bar] [White Bar] |

## Turning On

The battery is off when it leaves the factory. Please turn the battery on after connecting it to the system for the first time.

### ! CAUTION

- DO NOT turn the battery on until completing and securing the power connection. Connecting a turned on battery to the system can trigger the short circuit or overcurrent protection of the battery.

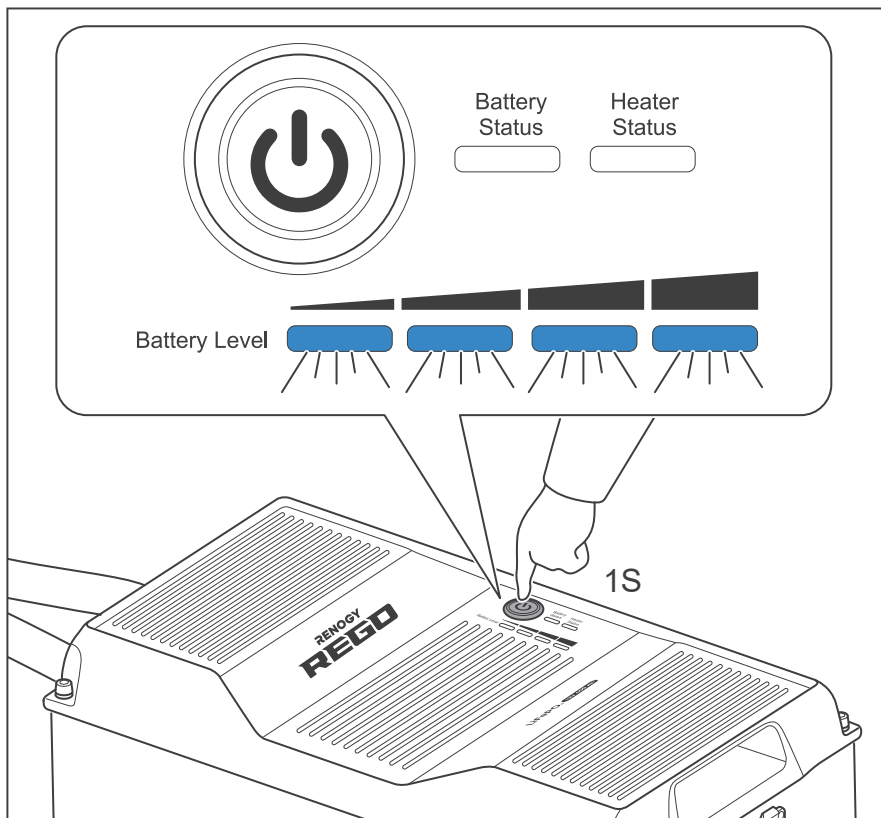

1. Long press the Power Button for 1 second or charge the battery to turn the battery on. The Battery Level Indicators fast flash blue simultaneously to indicate that the battery is turning on.

# Commission

Indicator  
Pattern

Turning  
On

Checking  
Battery Level

Checking  
Battery Status

Checking  
Heater Status

Changing  
Heater Settings

Charging

Discharging

Turning  
Off

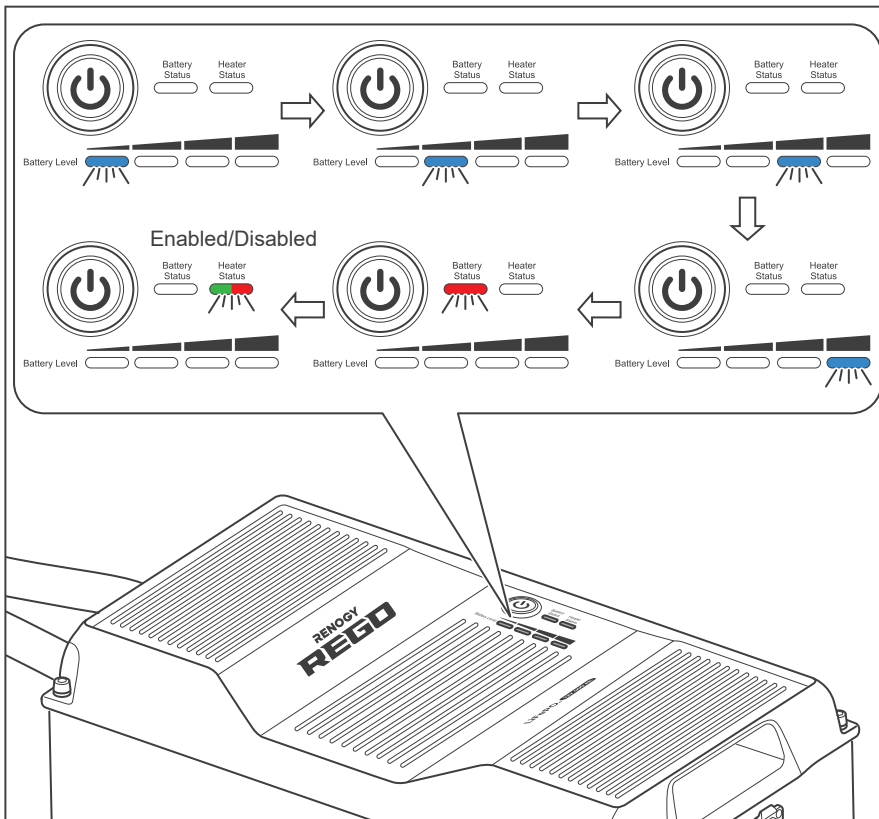

2. The Battery Level Indicators, Battery Status Indicator, and Heater Status Indicator flash in sequence once to indicate that the battery has been turned on. The color of the flashing Heater Status Indicator indicates the current heater setting.

## **i** NOTE

- Please refer to the [Changing Heater Setting](#) section for more information about the heater settings.

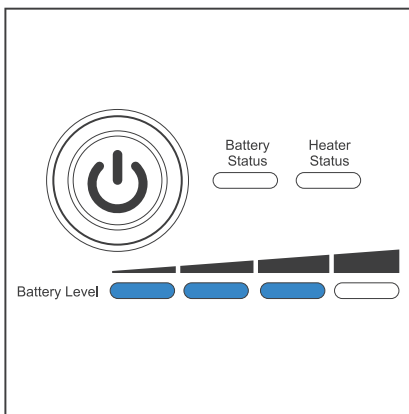

3. The Battery Level Indicators light up blue to indicate the current battery level.

## **!** CAUTION

- If the battery is unable to be turned on, please refer to the [Troubleshooting](#) section for troubleshooting instructions.

## **i** NOTE

- To turn on batteries connected in parallel simultaneously, please long press the Power Button on any battery for 1 second or charge the battery bank.

# Commission

Indicator  
Pattern

Turning  
On

Checking  
Battery Level

Checking  
Battery Status

Checking  
Heater Status

Changing  
Heater Settings

Charging

Discharging

Turning  
Off

## Checking Battery Level

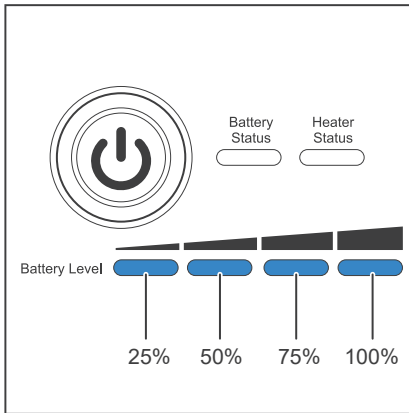

1. The four Battery Level Indicators respectively indicate 25%, 50%, 75%, and 100% battery level.

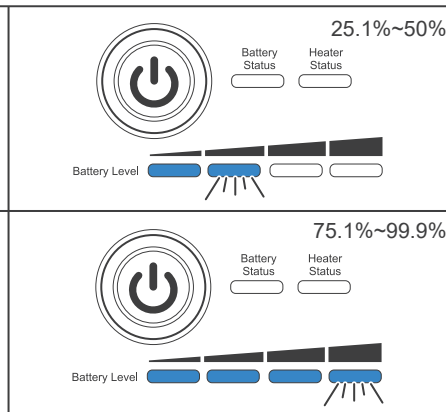
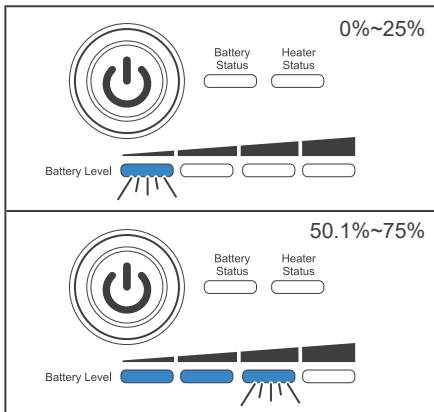

2. As the battery charges, the Battery Level Indicators light up blue one by one, and the rightmost Battery Level Indicator fast flashes blue to indicate the current battery level.

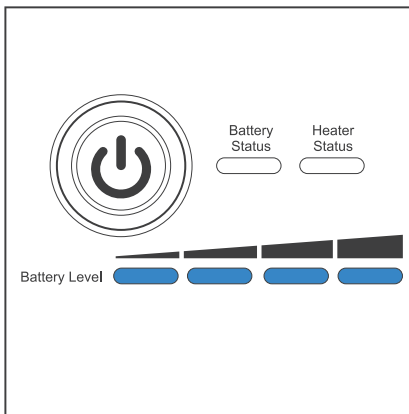

3. Once the battery is fully charged, all the Battery Level Indicators light up blue and remain solid.

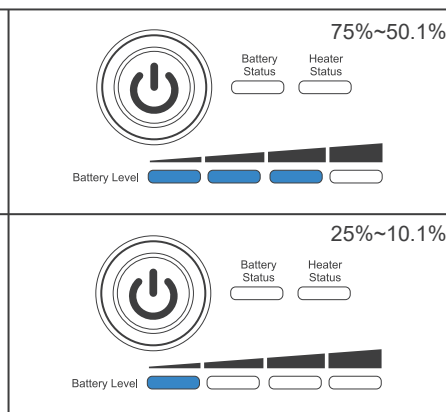
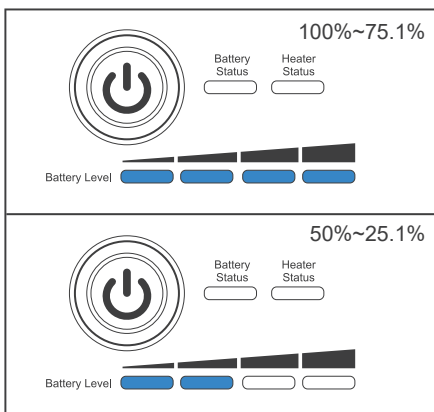

4. As the battery discharges, the Battery Level Indicators go out one by one.

# Commission

Indicator  
Pattern

Turning  
On

Checking  
Battery Level

Checking  
Battery Status

Checking  
Heater Status

Changing  
Heater Settings

Charging

Discharging

Turning  
Off

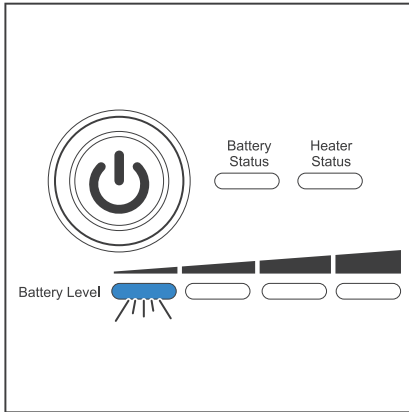

5. The last Battery Level Indicator slow flashes blue when the battery level drops below 10%.

## **i** NOTE

- The Battery Level Indicators go out when the battery is in the heater setting mode or permanent failure mode. Please refer to the [Changing Heater Setting](#) and [Checking Battery Status](#) sections for more information.

## Checking Battery Status

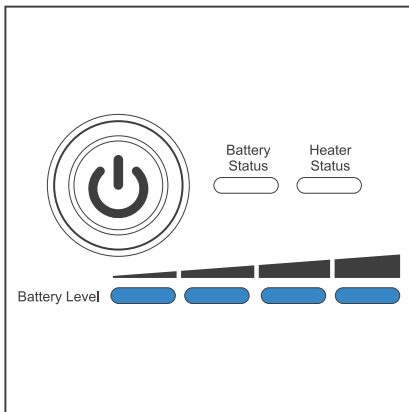

1. The Battery Status Indicator remains off when the battery is operating properly.

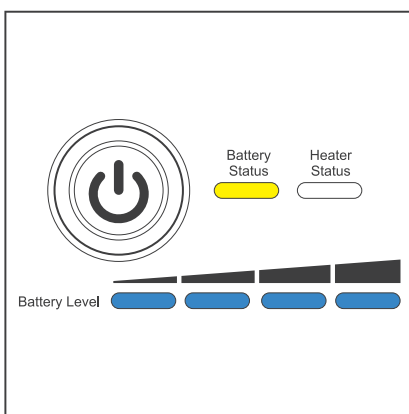

2. The Battery Status Indicator lights up/flashes yellow when the battery is in the warning mode.

# Commission

Indicator  
Pattern

Turning  
On

Checking  
Battery Level

Checking  
Battery Status

Checking  
Heater Status

Changing  
Heater Settings

Charging

Discharging

Turning  
Off

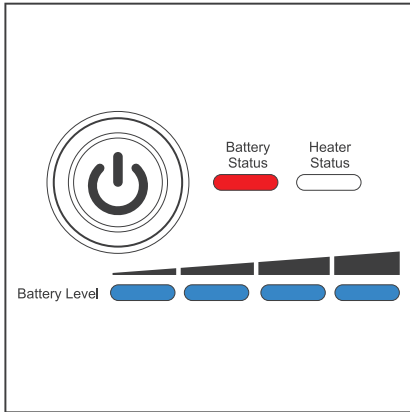

3. The Battery Status Indicator lights up/flashes red when the battery is in the protection mode.

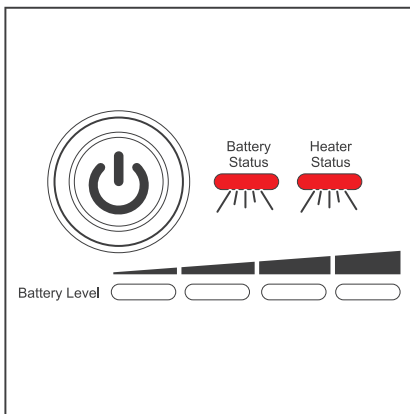

4. The Battery Status Indicator and Heater Status Indicator flash red simultaneously when the battery is in the permanent failure mode.

## **i** NOTE

- Please refer to the [Troubleshooting](#) section for the lighting/flashing pattern of the Battery Status Indicator and Heater Status Indicator and troubleshooting instructions under different warnings, protections, and permanent failures.
- The warnings do not affect the normal operation of the battery, but it is recommended to pay closer attention to the battery to prevent triggering the protections and/or permanent failures.

## Checking Heater Status

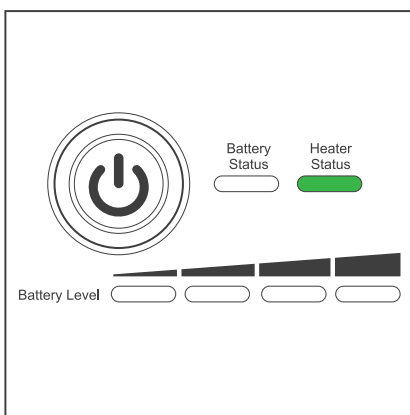

1. When the battery temperature drops below 41°F (5°C), and the charge current is stable and greater than 15A, the heater starts operating automatically, and the Heater Status Indicator lights up green.

# Commission

Indicator  
Pattern

Turning  
On

Checking  
Battery Level

Checking  
Battery Status

Checking  
Heater Status

Changing  
Heater Settings

Charging

Discharging

Turning  
Off

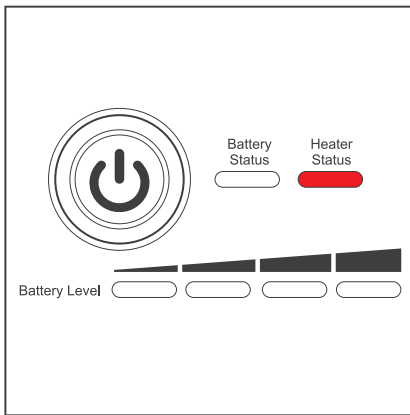

2. When the battery temperature drops below 41°F (5°C), but the charge current is unstable or less than 15A, or the heater malfunctions, the heater is unable to operate properly, and the Heater Status Indicator lights up red.

## **i** NOTE

- Please refer to the [Troubleshooting](#) section for troubleshooting instructions.

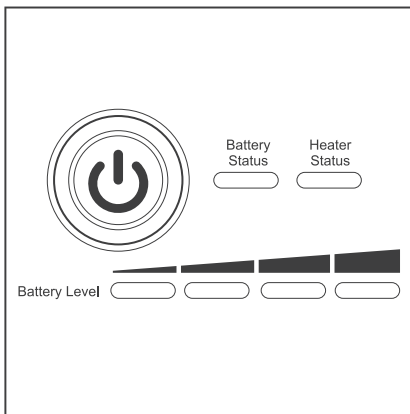

3. When the battery temperature rises above 50°F (10°C), or the charge current ceases, the heater stops operating automatically and the Heater Status Indicator goes out.

## **i** NOTE

- The heater does not operate if the battery temperature drops below -4°F (-20°C).
- For batteries connected in parallel, each battery requires a stable charge current greater than 15A for the proper operation of the heater.



## Changing Heater Settings

The battery leaves the factory with the heater enabled. The heater can be enabled or disabled with the Power Button.

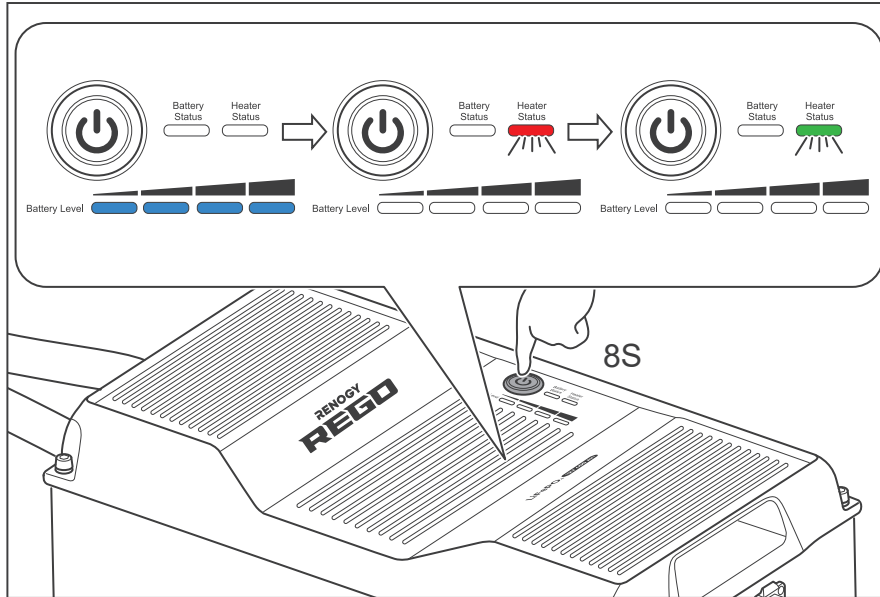

1. Long press the Power Button for 8 seconds to enter the heater setting mode. The Heater Status Indicator flashes red and green once.

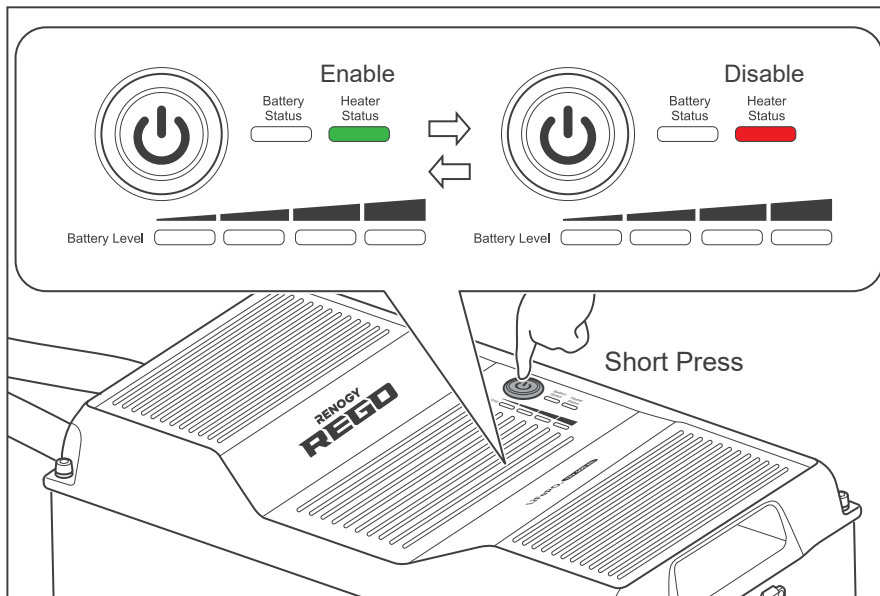

2. Short press the Power Button to enable or disable the heater. The Heater Status Indicator turns green to indicate that the heater is enabled or turns red to indicate that the heater is disabled.

# Commission

Indicator  
Pattern

Turning  
On

Checking  
Battery Level

Checking  
Battery Status

Checking  
Heater Status

Changing  
Heater Settings

Charging

Discharging

Turning  
Off

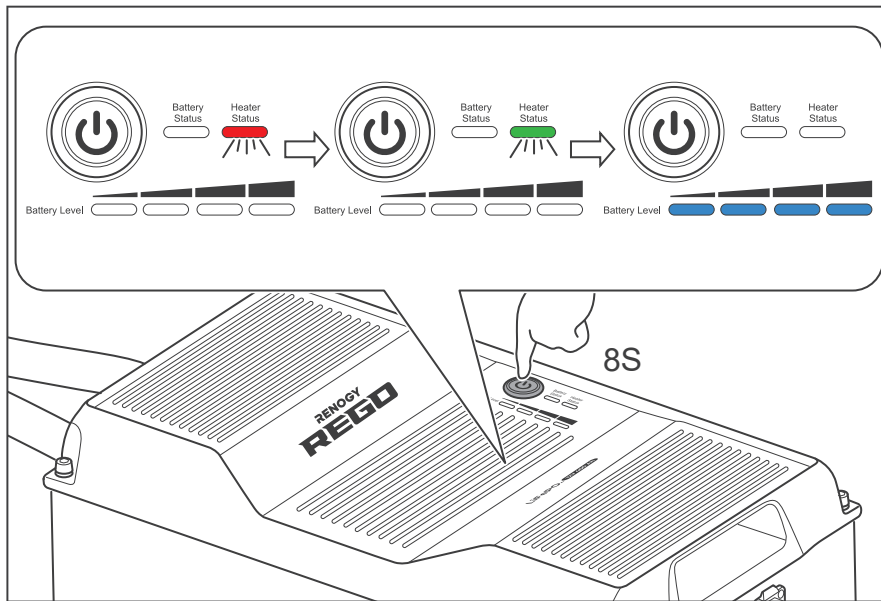

3. Long press the Power Button for 8 seconds to exit the heater setting mode and save the current setting. The Heater Status Indicator flashes red and green once.

## **i** NOTE

- The battery automatically exits the heater setting mode and saves the current setting 10 minutes after entering the heater setting mode if it is not done manually.
- To enable or disable the heaters of batteries connected in parallel simultaneously, please establish the inter-battery communication connection and enable or disable the heater of any battery with the Power Button. If the inter-battery communication connection is not established, please enable or disable the heater of each battery individually. The heater setting **MUST** be uniform across the batteries.
- The heater is unable to operate properly at low temperatures with PWM charge controllers or low current chargers. It is recommended to disable the heater to prevent it from turning on and off repeatedly and draining the battery.

## Charging

During the standard charging process, the battery is first charged at a constant current of 80A until the battery voltage reaches 14.4V. Then, the battery is charged at a constant voltage of 14.4V while tapering the charge current. The standard charging process is considered complete when the charge current is less than 20A for 10 seconds. However, leaving the battery on float can help balance the cells and does not damage the battery. The standard charging process normally takes 5.5 hours.

## **!** WARNING

- **DO NOT** charge the battery at high temperatures above 131°F (55°C) or low temperatures above -4°F (-20°C). If the heater is disabled or unable to operate properly, charging the battery at low temperatures below 32°F (0°C) is **NOT** recommended.



## CAUTION

- DO NOT overcharge the battery.
- DO NOT exceed the maximum continuous charge current of the battery.
- Please charge the battery with the chargers (not included) that are compatible with the lithium iron phosphate battery and the charge voltage set at 14.4V.
- DO NOT charge the battery immediately after a long heavy run.
- Please charge the battery immediately when the battery level drops below 10% to prevent overdischarge.



## NOTE

- Please fully charge the battery prior to first use.

## Discharging



## WARNING

- DO NOT discharge the battery at high temperatures above 140°F (60°C) or low temperatures above -4°F (-20°C).



## CAUTION

- DO NOT overdischarge the battery.
- DO NOT exceed the maximum continuous discharge current of the battery.
- DO NOT connect high power loads to the battery when it is running low.

During the standard discharging process, the battery is first discharged at a constant current of 80A until the lowest cell voltage reaches 2.5V. Then, the battery enters protection mode and cuts off all the loads to prevent the battery from overdischarge.



## NOTE

- Partial discharges reduce battery stress and prolong battery cycle life. It is recommended to keep the depth of discharge below 80%.
- It is recommended to use the battery with loads featuring low voltage disconnect.

## Turning Off

Prior to long periods of storage, please disconnect the battery from the system and turn it off. With the low self-discharge rate when turned off, the battery can hold the charge for a long period of time.

# Commission

Indicator  
Pattern

Turning  
On

Checking  
Battery Level

Checking  
Battery Status

Checking  
Heater Status

Changing  
Heater Settings

Charging

Discharging

Turning  
Off

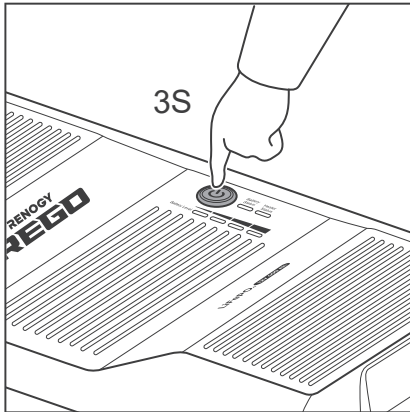

1. Long press the Power Button for 3 seconds.

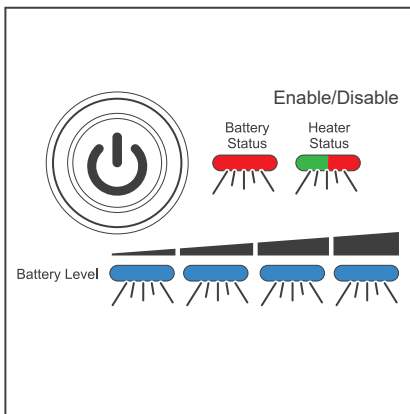

2. The Battery Level Indicators, Battery Status Indicator, and Heater Status Indicator fast flash simultaneously to indicate that the battery is turning off. The color of the flashing Heater Status Indicator indicates the current heater setting.

## **i** NOTE

- Please refer to the [Changing Heater Setting](#) section for more information about the heater settings.

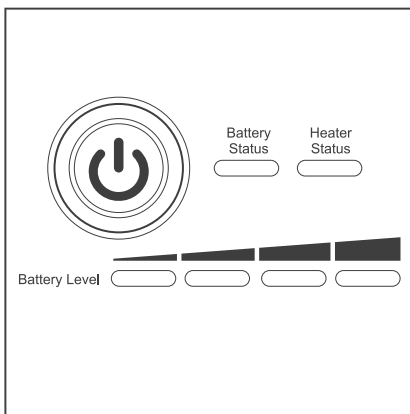

3. All the indicators go out to indicate that the battery has been turned off.

## **i** NOTE

- The battery is unable to be turned off if the Battery Level Indicators, Battery Status Indicator, and Heater Status Indicator keep fast flashing. Please check if the battery has been disconnected from the system.
- To turn off batteries connected in parallel simultaneously, please establish the communication connection and long press the Power Button on any battery for 3 seconds. If the communication connection is not established, please disconnect batteries connected in parallel and turn off each battery individually.

## Inspection

Please perform regular inspections following the steps below.

- Examine the external appearance of the battery. The housing and connector contacts of the battery shall be clean, dry, and free of corrosion.
- Check the battery cables and connections. Replace any damaged cables and tighten any loose connections.



### NOTE

- In some applications, corrosion can form around the contacts internal to the Anderson Connector. The corrosion can cause loosening of spring retention force and increase of mated contact resistance, leading to premature failure of the connection. Please apply dielectric grease onto each connector contact at regular intervals. Dielectric grease can repel moisture and protect the connector contact against corrosion.

## Cleaning

Please clean battery at regular intervals following the steps below.

- Disconnect the battery from the system.
- Turn the battery off with the Power Button.
- Clear the leaves and debris from the battery.
- Clean the battery with a soft, lint-free cloth. The cloth can be dampened with water or mild soap and water if the battery is extremely dirty.
- Dry the battery with a soft, lint-free cloth.
- Keep the area around the battery clean.
- Turn the battery back on with the Power Button.
- Reconnect the battery to the system.

## Storage

Please follow the tips below to ensure that the battery emerges from storage in a good condition.

- Charge the battery to 30%-50%.
- Disconnect the battery from the system.
- Turn the battery off with the Power Button.
- Store the battery in a well-ventilated, dry, clean area with temperatures between -4°F (-20°C) and 113°F (45°C).
- Handle the battery carefully to avoid sharp impacts or extreme pressure on the battery housing.
- Charge the battery at least once every 3 months to prevent it from overdischarge.
- Fully charge the battery when it is taken out of storage.

# Maintenance

Inspection

Cleaning

Storage



## CAUTION

- DO NOT expose the battery to extreme temperatures above 140°F (60°C).
- DO NOT expose the battery to heat sources.
- DO NOT expose the battery to direct sunlight, moisture, or precipitation.

# Battery Management System

Warning/Protection/Permanent Failure

Charge Current Request

Cell Voltage Balancing

## Warning/Protection/Permanent Failure

| Battery Status                                  | Trigger  |  |            |               |                  |                            |                        |                       | Release  |   | Comment  |
|---|--|--|------------|---------------|------------------|----------------------------|------------------------|-----------------------|--|---|----------|
|   | Threshold  | Sampling Time                          | Delay Time | Charge MOSFET | Discharge MOSFET | Communication Power Supply | Bluetooth Power Supply | BMS Power Supply      | Threshold  | Sampling Time                           |          |
| Cell Overvoltage Warning                        | Highest Cell Voltage > 3.6V                              | 3 Seconds                              | 0 Second   | Connect       | Connect          | On                         | On                     | On                    | Highest Cell Voltage < 3.45V/<br>Discharge Current ≥ 3A          | 1 Second                                |          |
| Cell Overvoltage Protection                     | Highest Cell Voltage > 3.7V                              | 5 Seconds                              | 3 Seconds  | Disconnect    | Connect          | On                         | On                     | On                    | Highest Cell Voltage < 3.45V/<br>Discharge Current ≥ 3A          | 1 Second                                |          |
| Cell Overvoltage Permanent Failure              | Highest Cell Voltage > 4.0V                              | 10 Seconds                             | 3 Seconds  | Disconnect    | Disconnect       | Off (Delay 5 Minutes)      | Off (Delay 5 Minutes)  | Off (Delay 5 Minutes) | Unrecoverable  | /                                       |          |
| Cell Undervoltage Warning                       | Lowest Cell Voltage < 3.0V                               | 3 Seconds                              | 0 Second   | Connect       | Connect          | On                         | On                     | On                    | Lowest Cell Voltage > 3.1V/<br>Charge Current ≥ 1A               | 1 Second                                |          |
| Cell Undervoltage Protection                    | Lowest Cell Voltage < 2.5V                               | 5 Seconds                              | 3 Seconds  | Connect       | Disconnect       | Off (Delay 5 Minutes)      | Off (Delay 5 Minutes)  | Off (Delay 5 Minutes) | Lowest Cell Voltage > 3.1V/<br>Charge Current ≥ 1A for 4 Minutes | 1 Second                                |          |
| Cell Undervoltage Permanent Failure             | Lowest Cell Voltage < 2.0V                               | 10 Seconds                             | 3 Seconds  | Disconnect    | Disconnect       | Off (Delay 5 Minutes)      | Off (Delay 5 Minutes)  | Off (Delay 5 Minutes) | Unrecoverable  | /                                       |          |
| Battery Overvoltage Warning                     | Battery Voltage > 14.4V                                  | 3 Seconds                              | 0 Second   | Connect       | Connect          | On                         | On                     | On                    | Battery Voltage < 13.8V/<br>Discharge Current ≥ 3A               | 1 Second                                |          |
| Battery Overvoltage Protection                  | Battery Voltage > 14.8V                                  | 5 Seconds                              | 3 Seconds  | Disconnect    | Connect          | On                         | On                     | On                    | Battery Voltage < 13.8V/<br>Discharge Current ≥ 3A               | 1 Second                                |          |
| Battery Undervoltage Warning                    | Battery Voltage < 12V                                    | 3 Seconds                              | 0 Second   | Connect       | Connect          | On                         | On                     | On                    | Battery Voltage > 12.4V/<br>Charge Current ≥ 1A                  | 1 Second                                |          |
| Battery Undervoltage Protection                 | Battery Voltage < 10V                                    | 5 Seconds                              | 3 Seconds  | Connect       | Disconnect       | Off (Delay 5 Minutes)      | Off (Delay 5 Minutes)  | Off (Delay 5 Minutes) | Battery Voltage > 12.4V/<br>Charge Current ≥ 1A for 4 Minutes    | 1 Second                                |          |
| Cell Charge High Temperature Warning            | Highest Cell Temperature > 50°C (122°F)                  | 3 Seconds                              | 0 Second   | Connect       | Connect          | On                         | On                     | On                    | Highest Cell Temperature < 45°C (113°F)                          | 1 Second                                |          |
| Cell Charge High Temperature Protection         | Highest Cell Temperature > 55°C (131°F)                  | 5 Seconds                              | 3 Seconds  | Disconnect    | Connect          | On                         | On                     | On                    | Highest Cell Temperature < 50°C (122°F)                          | 1 Second                                |          |
| Cell Discharge/Idle High Temperature Warning    | Highest Cell Temperature > 55°C (131°F)                  | 3 Seconds                              | 0 Second   | Connect       | Connect          | On                         | On                     | On                    | Highest Cell Temperature < 50°C (122°F)                          | 1 Second                                |          |
| Cell Discharge/Idle High Temperature Protection | Highest Cell Temperature > 60°C (140°F)                  | 5 Seconds                              | 3 Seconds  | Connect       | Disconnect       | On                         | On                     | On                    | Highest Cell Temperature < 55°C (131°F)                          | 1 Second                                |          |
| Cell High Temperature Permanent Failure         | Highest Cell Temperature > 70°C (158°F)                  | 10 Seconds                             | 3 Seconds  | Disconnect    | Disconnect       | Off (Delay 5 Minutes)      | Off (Delay 5 Minutes)  | Off (Delay 5 Minutes) | Unrecoverable  | /                                       |          |
| Cell Charge Low Temperature Warning             | Lowest Cell Temperature < 3°C (37.4°F)                   | 3 Seconds                              | 0 Second   | Connect       | Connect          | On                         | On                     | On                    | Lowest Cell Temperature > 6°C (42.8°F)                           | 1 Second                                |          |
| Cell Charge Low Temperature Protection          | Charge Current < 23.6A                                   | Lowest Cell Temperature < -20°C (-4°F) | 5 Seconds  | 3 Seconds     | Disconnect       | Connect                    | On                     | On                    | On   | Lowest Cell Temperature > -17°C (1.4°F) | 1 Second |
|   | Charge Current ≥ 23.6A                                   |  |            |               |                  |                            |                        |                       |  |   |          |
| Cell Discharge/Idle Low Temperature Warning     | Lowest Cell Temperature < -17°C (1.4°F)                  | 3 Seconds                              | 0 Second   | Connect       | Connect          | On                         | On                     | On                    | Lowest Cell Temperature > -14°C (6.8°F)                          | 1 Second                                |          |
| Cell Discharge/Idle Low Temperature Protection  | Lowest Cell Temperature < -20°C (-4°F)                   | 5 Seconds                              | 3 Seconds  | Connect       | Disconnect       | On                         | On                     | On                    | Lowest Cell Temperature > -17°C (1.4°F)                          | 1 Second                                |          |
| Environment High Temperature Warning            | Battery Interior Environment Temperature > 75°C (167°F)  | 3 Seconds                              | 0 Second   | Connect       | Connect          | On                         | On                     | On                    | Battery Interior Environment Temperature < 65°C (149°F)          | 1 Second                                |          |
| Environment High Temperature Protection         | Battery Interior Environment Temperature > 80°C (176°F)  | 5 Seconds                              | 3 Seconds  | Disconnect    | Disconnect       | Off (Delay 1 Minute)       | Off (Delay 1 Minute)   | Off (Delay 1 Minute)  | Battery Interior Environment Temperature < 65°C (149°F)          | 1 Second                                |          |
| Environment Low Temperature Warning             | Battery Interior Environment Temperature < -30°C (-22°F) | 3 Seconds                              | 0 Second   | Connect       | Connect          | On                         | On                     | On                    | Battery Interior Environment Temperature > -25°C (-13°F)         | 1 Second                                |          |
| Environment Low Temperature Protection          | Battery Interior Environment Temperature < -35°C (-31°F) | 5 Seconds                              | 3 Seconds  | Disconnect    | Disconnect       | Off (Delay 1 Minute)       | Off (Delay 1 Minute)   | Off (Delay 1 Minute)  | Battery Interior Environment Temperature > -25°C (-13°F)         | 1 Second                                |          |
| Cell Imbalance Warning                          | Cell Voltage Difference > 600mV                          | 3 Seconds                              | 0 Second   | Connect       | Connect          | On                         | On                     | On                    | Cell Voltage Difference < 200mV                                  | 1 Second                                |          |
| Cell Imbalance Protection                       | Cell Voltage Difference > 1000mV                         | 5 Seconds                              | 3 Seconds  | Disconnect    | Disconnect       | On                         | On                     | On                    | Cell Voltage Difference < 200mV                                  | 1 Second                                |          |



# Battery Management System

Warning/Protection/Permanent Failure

Charge Current Request

Cell Voltage Balancing

| Battery Status                             | Trigger   |                                |                  |            |               |                  |                            |                        |                       | Release   |                  | Comment  |  |
|--|---|--------------------------------|------------------|------------|---------------|------------------|----------------------------|------------------------|-----------------------|---|------------------|--|--|
|  | Threshold   |                                | Sampling Time    | Delay Time | Charge MOSFET | Discharge MOSFET | Communication Power Supply | Bluetooth Power Supply | BMS Power Supply      | Threshold   | Sampling Time    |  |  |
| Charge Overcurrent Warning                 | Cell Temperature $\leq 15^{\circ}\text{C}$ (59°F)                               | Charge Current $> 220\text{A}$ | 3 Seconds        | 0 Second   | Connect       | Connect          | On                         | On                     | On                    | Charge Current $< 200\text{A}$  | 1 Second         |  |  |
|  | $15^{\circ}\text{C}$ (59°F) $<$ Cell Temperature $< 50^{\circ}\text{C}$ (131°F) | Charge Current $> 330\text{A}$ |                  |            |               |                  |                            |                        |                       | Charge Current $< 300\text{A}$  |                  |  |  |
|  | Cell Temperature $\geq 55^{\circ}\text{C}$ (131°F)                              | Charge Current $> 220\text{A}$ |                  |            |               |                  |                            |                        |                       | Charge Current $< 200\text{A}$  |                  |  |  |
| Charge Overcurrent Primary Protection      | Cell Temperature $\leq 15^{\circ}\text{C}$ (59°F)                               | Charge Current $> 230\text{A}$ | 15 Seconds       | 3 Seconds  | Disconnect    | Connect          | On                         | On                     | On                    | Charge Current $< 200\text{A}/$<br>Discharge Current $\geq 3\text{A}$ | 1 Second         | The battery automatically attempts to recover 1 minute after the protection. The interval between each attempt is 1 minute. If the battery fails 3 consecutive attempts, the protection can only be released with a discharge current greater than 3A. |  |
|  | $15^{\circ}\text{C}$ (59°F) $<$ Cell Temperature $< 50^{\circ}\text{C}$ (131°F) | Charge Current $> 345\text{A}$ |                  |            |               |                  |                            |                        |                       | Charge Current $< 300\text{A}/$<br>Discharge Current $\geq 3\text{A}$ |                  |  |  |
|  | Cell Temperature $\geq 55^{\circ}\text{C}$ (131°F)                              | Charge Current $> 230\text{A}$ |                  |            |               |                  |                            |                        |                       | Charge Current $< 200\text{A}/$<br>Discharge Current $\geq 3\text{A}$ |                  |  |  |
| Charge Overcurrent Secondary Protection    | Cell Temperature $\leq 15^{\circ}\text{C}$ (59°F)                               | Charge Current $> 236\text{A}$ | 5 Seconds        | 3 Seconds  | Disconnect    | Connect          | On                         | On                     | On                    | Charge Current $< 200\text{A}/$<br>Discharge Current $\geq 3\text{A}$ | 1 Second         |  |  |
|  | $15^{\circ}\text{C}$ (59°F) $<$ Cell Temperature $< 50^{\circ}\text{C}$ (131°F) | Charge Current $> 354\text{A}$ |                  |            |               |                  |                            |                        |                       | Charge Current $< 300\text{A}/$<br>Discharge Current $\geq 3\text{A}$ |                  |  |  |
|  | Cell Temperature $\geq 55^{\circ}\text{C}$ (131°F)                              | Charge Current $> 236\text{A}$ |                  |            |               |                  |                            |                        |                       | Charge Current $< 200\text{A}/$<br>Discharge Current $\geq 3\text{A}$ |                  |  |  |
| Discharge Overcurrent Warning              | Discharge Current $> 385\text{A}$   |                                | 3 Seconds        | 0 Second   | Connect       | Connect          | On                         | On                     | On                    | Discharge Current $< 350\text{A}$                                     | 1 Second         |  |  |
| Discharge Overcurrent Primary Protection   | Discharge Current $> 402.5\text{A}$   |                                | 15 Seconds       | 3 Seconds  | Connect       | Disconnect       | On                         | On                     | On                    | Discharge Current $< 350\text{A}/$<br>Charge Current $\geq 1\text{A}$ | 1 Second         | The battery automatically attempts to recover 1 minute after the protection.   |  |
| Discharge Overcurrent Secondary Protection | Discharge Current $> 413\text{A}$   |                                | 5 Seconds        | 3 Seconds  | Connect       | Disconnect       | On                         | On                     | On                    | Discharge Current $< 350\text{A}/$<br>Charge Current $\geq 1\text{A}$ | 1 Second         | The interval between each attempt is 1 minute. If the battery fails 3 consecutive attempts, the protection can only be released with a charge current greater than 1A.   |  |
| Discharge Overcurrent Hardware Protection  | Discharge Current $> 700\text{A}$   |                                | 100 Microseconds | 0 Second   | Disconnect    | Disconnect       | On                         | On                     | On                    | Discharge Current $< 350\text{A}/$<br>Charge Current $\geq 1\text{A}$ | 100 Microseconds |  |  |
| Low SOH Warning                            | SOH $< 55\%$  |                                | 3 Seconds        | 0 Second   | Connect       | Connect          | On                         | On                     | On                    | SOH $> 56\%$  | 1 Second         |  |  |
| Low SOH Permanent Failure                  | SOH $< 50\%$  |                                | 5 Seconds        | 3 Seconds  | Disconnect    | Disconnect       | Off (Delay 5 Minutes)      | Off (Delay 5 Minutes)  | Off (Delay 5 Minutes) | Unrecoverable   | /                |  |  |
| Low SOC Warning                            | SOC $\leq 2\%$  |                                | 3 Seconds        | 0 Second   | Connect       | Connect          | On                         | On                     | On                    | SOC $> 4\%$ /<br>Charge Current $\geq 1\text{A}$                      | 1 Second         |  |  |
| CAN Communication Error Warning            | Unable to Receive CAN Messages for 1 Minute                                     |                                | 1 Minute         | 0 Second   | Connect       | Connect          | On                         | On                     | On                    | Receives CAN Messages   | 0 Second         |  |  |
| Short Circuit Protection                   | Short Circuit Current $> 800\text{A}$   |                                | 1 Millisecond    | 0 Second   | Connect       | Disconnect       | On                         | On                     | On                    | Remove Short Circuit/<br>Charge Current $\geq 1\text{A}$              | 1 Second         | The battery automatically attempts to recover 1 minute after the protection. The interval between each attempt is 1 minute. If the battery fails 3 consecutive attempts, the protection can only be released with a charge current greater than 1A.    |  |
| Reverse Polarity Protection                | Connection Polarity Reverse   |                                | 0 Second         | 0 Second   | Disconnect    | Disconnect       | Off (Delay 5 Minutes)      | Off (Delay 5 Minutes)  | Off (Delay 5 Minutes) | Connection Polarity Correct   | 0 Second         |  |  |
| Pre-Charge Failure Protection              | Voltage Difference Across Pre-Charge MOSFETE $> 4\text{V}$                      |                                | 0 Second         | 0 Second   | Disconnect    | Disconnect       | On                         | On                     | On                    | Voltage Difference Across Pre-Charge MOSFETE $< 1\text{V}$            | 0 Second         | The battery automatically attempts to recover 1 minute after the protection. The interval between each attempt is 1 minute. If the battery fails 3 consecutive attempts, the protection can only be released with a restart.                           |  |
| Battery Source Address Conflict Warning    | Source Address Conflict between Devices   |                                | 0 Second         | 0 Second   | Connect       | Connect          | On                         | On                     | On                    | Finds Unclaimed Source Address  | 0 Second         |  |  |
| AFE Communication Error Protection         | Unable to Receive AFE Messages for 10 Seconds                                   |                                | 10 Seconds       | 3 Seconds  | Disconnect    | Disconnect       | Off (Delay 5 Minutes)      | Off (Delay 5 Minutes)  | Off (Delay 5 Minutes) | Receives AFE Messages   | 0 Second         |  |  |
| Memory Communication Error Warning         | Communication Between EEPROM and Flash Memory Fails 3 Times                     |                                | 0 Second         | 0 Second   | Connect       | Connect          | On                         | On                     | On                    | Communication Between EEPROM and Flash Memory Succeeds                | 0 Second         |  |  |



# Battery Management System

Warning/Protection/Permanent Failure

Charge Current Request

Cell Voltage Balancing

| Battery Status                                 | Trigger   |               |   |               |                  |                            |                        |                       | Release   |               | Comment  |
|--|---|---------------|---|---------------|------------------|----------------------------|------------------------|-----------------------|---|---------------|--|
|  | Threshold   | Sampling Time | Delay Time                                | Charge MOSFET | Discharge MOSFET | Communication Power Supply | Bluetooth Power Supply | BMS Power Supply      | Threshold   | Sampling Time |  |
| MOSFET High Temperature Warning                | MOSFET Temperature > 85°C (185°F)   | 3 Seconds     | 0 Second                                  | Connect       | Connect          | On                         | On                     | On                    | MOSFET Temperature < 80°C (176°F)                         | 1 Second      |  |
| MOSFET High Temperature Protection             | MOSFET Temperature > 105°C (221°F)  | 5 Seconds     | 3 Seconds                                 | Disconnect    | Disconnect       | Off (Delay 5 Minutes)      | Off (Delay 5 Minutes)  | Off (Delay 5 Minutes) | MOSFET Temperature < 90°C (194°F)                         | 1 Second      |  |
| Balancing Circuit High Temperature Warning     | Balancing Circuit > 85°C (185°F)  | 3 Seconds     | 0 Second                                  | Connect       | Connect          | On                         | On                     | On                    | Balancing Circuit < 80°C (176°F)                          | 1 Second      |  |
| Balancing Circuit High Temperature Protection  | Balancing Circuit > 105°C (221°F)   | 5 Seconds     | 3 Seconds                                 | Disconnect    | Disconnect       | Off (Delay 5 Minutes)      | Off (Delay 5 Minutes)  | Off (Delay 5 Minutes) | Balancing Circuit < 85°C (185°F)                          | 1 Second      |  |
| Temperature Sampling Error Protection          | Unable to Detect Temperature Sampling Signal  | 3 Seconds     | 3 Seconds                                 | Disconnect    | Disconnect       | Off (Delay 5 Minutes)      | Off (Delay 5 Minutes)  | Off (Delay 5 Minutes) | Detects Temperature Sampling Signal                       | 0 Second      |  |
| Charge MOSFET Permanent Failure                | Charge Current ≥ 3A When Disconnecting Charge MOSFET is Required/<br>Unable To Connect Charge MOSFET When Required          | 0 Second      | 3 Seconds                                 | Disconnect    | Disconnect       | Off (Delay 1 Minute)       | Off (Delay 1 Minute)   | Off (Delay 1 Minute)  | Unrecoverable   | /             |  |
| Discharge MOSFET Permanent Failure             | Discharge Current ≥ 3A When Disconnecting Discharge MOSFET is Required/<br>Unable To Connect Discharge MOSFET When Required | 0 Second      | 3 Seconds                                 | Disconnect    | Disconnect       | Off (Delay 1 Minute)       | Off (Delay 1 Minute)   | Off (Delay 1 Minute)  | Unrecoverable   | /             |  |
| Voltage Sampling Error Protection              | Difference Between Voltages Sampled by MCU and AFE > 1V   | 3 Seconds     | 3 Seconds                                 | Disconnect    | Disconnect       | Off (Delay 5 Minutes)      | Off (Delay 5 Minutes)  | Off (Delay 5 Minutes) | Difference Between Voltages Sampled by MCU and AFE < 0.5V | 1 Second      |  |
| Communication Power Supply Malfunction Warning | Communication Power Supply Voltage ≤ 10V/<br>Communication Power Supply Voltage ≥ 14.8V                                     | 5 Seconds     | 0 Second                                  | Connect       | Connect          | Off (Delay 5 Seconds)      | On                     | On                    | 10V < Communication Power Supply Voltage < 14.8V          | 1 Second      |  |
| RTC Error Warning                              | Unable to Receive RTC Messages for 10 Seconds   | 10 Seconds    | 0 Second                                  | Connect       | Connect          | On                         | On                     | On                    | Receives RTC Messages                                     | 0 Second      |  |
| Heater High Temperature Warning                | Heater Temperature > 75°C (167°F)   | 3 Seconds     | 0 Second                                  | Connect       | Connect          | On                         | On                     | On                    | Heater Temperature < 50°C (122°F)                         | 1 Second      |  |
| Heater High Temperature Protection             | Heater Temperature > 85°C (185°F)   | 5 Seconds     | 3 Seconds                                 | Disconnect    | Disconnect       | On                         | On                     | On                    | Heater Temperature < 70°C (158°F)                         | 1 Second      |  |
| Heater High Temperature Hardware Protection    | Heater Temperature > 90°C (194°F)   | 10 Seconds    | 3 Seconds                                 | Disconnect    | Disconnect       | Off (Delay 1 Minute)       | Off (Delay 1 Minute)   | Off (Delay 1 Minute)  | Heater Temperature < 65°C (149°F)                         | Restart       | The heater fuse blows when the protection is triggered. The heater is unable to operate anymore even the protection is released. |
| Heater Malfunction Warning                     | Unable to Heat Battery Up When Heater is On   | 5 Seconds     | 0 Second                                  | Connect       | Connect          | On                         | On                     | On                    | Heats Battery Up When Heater is On                        | 0 Second      |  |
| Fuse Permanent Failure                         | Voltage Difference Across > 5V  | 3 Seconds     | 3 Seconds                                 | Disconnect    | Disconnect       | Off (Delay 5 Minutes)      | Off (Delay 5 Minutes)  | Off (Delay 5 Minutes) | Unrecoverable   | /             |  |
| AFE Overvoltage Protection                     | AFE Sampled Cell Voltage > 3.9V   | 0 Second      | 0 Second                                  | Disconnect    | Disconnect       | On                         | On                     | On                    | AFE Sampled Cell Voltage < 3.9V                           | Restart       |  |
| AFE Undervoltage Protection                    | AFE Sampled Cell Voltage < 2V   | 0 Second      | 0 Second                                  | Disconnect    | Disconnect       | Off (Delay 1 Minute)       | Off (Delay 1 Minute)   | Off (Delay 1 Minute)  | AFE Sampled Cell Voltage > 2V                             | Restart       |  |
| BMS Power Supply Malfunction Protection        | BMS Power Supply Voltage ≤ 13.2V/<br>BMS Power Supply Voltage ≥ 10.8V   | 5 Seconds     | 3 Seconds<br>(BMS Power Supply Undamaged) | Disconnect    | Disconnect       | Off (Delay 5 Minutes)      | Off (Delay 5 Minutes)  | Off (Delay 5 Minutes) | 10.8V < BMS Power Supply Voltage < 13.2V                  | 5 Seconds     |  |
| AFE High Temperature Protection                | AFE Sampled Cell Temperature > 65°C (149°F)   | 0 Second      | 3 Seconds                                 | Disconnect    | Disconnect       | On                         | On                     | On                    | AFE Sampled Cell Temperature < 60°C (140°F)               | 1 Second      |  |
| AFE Low Temperature Protection                 | AFE Sampled Cell Temperature < -25°C (-13°F)  | 0 Second      | 3 Seconds                                 | Disconnect    | Disconnect       | On                         | On                     | On                    | AFE Sampled Cell Temperature > -20°C (-4°F)               | 1 Second      |  |

# Battery Management System

Warning/Protection/Permanent Failure

Charge Current Request

Cell Voltage Balancing

## Charge Current Request

With the communication connections established between the battery and chargers, the battery management system can automatically request appropriate charge current from the chargers based on the cell voltage and temperature to prolong battery cycle life.

| Cell Temperature<br>Highest Cell Voltage    | Desired Charge Current |                                |                              |                               |                                |                                   |                                  |                                  |                                    |                     |
|---|------------------------|--------------------------------|------------------------------|-------------------------------|--------------------------------|-----------------------------------|----------------------------------|----------------------------------|------------------------------------|---------------------|
|   | <-19°C<br>(-2.2°F)     | -19°C ~ 0°C<br>(-2.2°F ~ 32°F) | 0°C ~ 1°C<br>(32°F ~ 33.8°F) | 1°C ~ 15°C<br>(33.8°F ~ 59°F) | 15°C ~ 16°C<br>(59°F ~ 60.8°F) | 16°C ~ 49°C<br>(60.8°F ~ 120.2°F) | 49°C ~ 50°C<br>(120.2°F ~ 122°F) | 50°C ~ 53°C<br>(122°F ~ 127.4°F) | 53°C ~ 54°C<br>(127.4°F ~ 129.2°F) | > 54°C<br>(129.2°F) |
| Cell Undervoltage<br>Permanent Failure      | 0A                     | 0A                             | 0A                           | 0A                            | 0A                             | 0A                                | 0A                               | 0A                               | 0A                                 | 0A                  |
| Cell Undervoltage<br>Permanent Failure~2.5V | 0A                     | 5A                             | 5A → 40A                     | 40A                           | 40A                            | 40A                               | 40A                              | 40A                              | 40A → 20A                          | 0A                  |
| 2.5V~3.5V                                   | 0A                     | 5A                             | 5A → 200A                    | 200A                          | 200A → 300A                    | 300A                              | 300A → 100A                      | 100A                             | 100A → 20A                         | 0A                  |
| 3.5V~3.54V                                  | 0A                     | 5A                             | ↓                            | ↓                             | ↓                              | ↓                                 | ↓                                | ↓                                | ↓                                  | 0A                  |
| 3.54V~Full                                  | 0A                     | 5A                             | 5A                           | 5A                            | 15A                            | 15                                | 15                               | 15                               | 15                                 | 0A                  |
| Full  | 0A                     | 0A                             | 0A                           | 0A                            | 0A                             | 0A                                | 0A                               | 0A                               | 0A                                 | 0A                  |



### NOTE

- After a full charge, the battery stops requesting charge current until the battery level drops below 95%.

## Cell Voltage Balancing

The battery management system is equipped with a passive balancing circuit to balance the cell voltages. Each series connected cell is connected to a bypass resistor and a switch. During the charging process, the battery management system turns on the switch for the cell whose voltage is significantly higher than other cells and shunts the charge current through its bypass resistor until the voltage difference between cells gets small enough. To avoid excessive energy loss, the cell voltage balancing is only performed during the charging process.

# Troubleshooting

| Phenomenon               |  | Possible Causes               | Solutions  |
|--------------------------|--|-------------------------------|--|
| Battery Status Indicator | Heater Status Indicator                            |                               |  |
| Solid Yellow             |  | Charge Overcurrent Warning    | <ul style="list-style-type: none"> <li>Reduce the charge current immediately.</li> </ul>   |
|                          |  | Discharge Overcurrent Warning | <ul style="list-style-type: none"> <li>Reduce the discharge current immediately.</li> </ul>  |
| Slow Flash Yellow        | Lights up / Flashes According to the Heater Status | Cell Overvoltage Warning      | <ul style="list-style-type: none"> <li>Ensure that the chargers are compatible with the lithium iron phosphate battery.</li> <li>Ensure that the battery type is set to lithium iron phosphate and the charge voltage is set to 14.4V on the chargers. Slightly reduce the charge voltage or connect voltage sensors to the chargers to compensate for the voltage drops across the charging cables if necessary.</li> <li>The charging can be continued if the chargers are compatible with the lithium iron phosphate battery and the battery type and charge voltage are set properly on the chargers.</li> </ul> |
|                          |  | Battery Overvoltage Warning   | <ul style="list-style-type: none"> <li>Ensure that the chargers are compatible with the lithium iron phosphate battery.</li> <li>Ensure that the battery type is set to lithium iron phosphate and the charge voltage is set to 14.4V on the chargers. Slightly reduce the charge voltage or connect voltage sensors to the chargers to compensate for the voltage drops across the charging cables if necessary.</li> <li>The charging can be continued if the chargers are compatible with the lithium iron phosphate battery and the battery type and charge voltage are set properly on the chargers.</li> </ul> |
|                          |  | Cell Undervoltage Warning     | <ul style="list-style-type: none"> <li>Charge the battery immediately.</li> </ul>  |
|                          |  | Battery Undervoltage Warning  | <ul style="list-style-type: none"> <li>Charge the battery immediately.</li> </ul>  |
|                          |  | Low SOC Warning               | <ul style="list-style-type: none"> <li>Charge the battery immediately.</li> </ul>  |

# Troubleshooting

| Phenomenon               |  | Possible Causes                                | Solutions   |
|--------------------------|--|--|---|
| Battery Status Indicator | Heater Status Indicator                            |  |   |
| Slow Flash<br>Yellow     | Lights up / Flashes According to the Heater Status | Cell Voltage Imbalance Warning                 | <ul style="list-style-type: none"> <li>• Disconnect the battery from the system.</li> <li>• Leave the battery resetting for 24 hours.</li> <li>• <a href="#">Contact us</a> for help if the warning persists</li> </ul>                         |
| Fast Flash<br>Yellow     |  | CAN Communication Error Warning                | <ul style="list-style-type: none"> <li>• Ensure that the inter-device communication connections are solid.</li> <li>• Restart the battery if no inter-device communication connection is established.</li> </ul>                                |
|                          |  | Battery Source Address Conflict Warning        | <ul style="list-style-type: none"> <li>• Restart the battery.</li> <li>• <a href="#">Contact us</a> for help if the warning persists.</li> </ul>  |
|                          |  | Memory Communication Error Warning             | <ul style="list-style-type: none"> <li>• Restart the battery.</li> <li>• The memory connection might have been loose if the warning persists. <a href="#">Contact us</a> for help.</li> </ul>   |
|                          |  | RTC Error Warning                              | <ul style="list-style-type: none"> <li>• Restart the battery.</li> <li>• The RTC connection might have been loose if the warning persists. <a href="#">Contact us</a> for help.</li> </ul>  |
|                          |  | Communication Power Supply Malfunction Warning | <ul style="list-style-type: none"> <li>• Restart the battery.</li> <li>• The communication power supply might have been damaged if the warning persists. <a href="#">Contact us</a> for help.</li> </ul>  |
| Strobe Yellow            |  | Cell Charge High Temperature Warning           | <ul style="list-style-type: none"> <li>• Increase the airflow for efficient heat dissipation.</li> <li>• Insulate the battery from hot weather if necessary.</li> <li>• Reduce the charge current to avoid internal heat buildup.</li> </ul>    |
|                          |  | Cell Discharge/ Idle High Temperature Warning  | <ul style="list-style-type: none"> <li>• Increase the airflow for efficient heat dissipation.</li> <li>• Insulate the battery from hot weather if necessary.</li> <li>• Reduce the discharge current to avoid internal heat buildup.</li> </ul> |

# Troubleshooting

| Phenomenon               |  | Possible Causes                              | Solutions   |
|--------------------------|--|--|---|
| Battery Status Indicator | Heater Status Indicator                            |  |   |
| Strobe Yellow            | Lights up / Flashes According to the Heater Status | Cell Charge Low Temperature Warning          | <ul style="list-style-type: none"> <li>• Insulate the battery from cold weather.</li> <li>• Ensure that the heater is enabled and operating properly.</li> </ul>  |
|                          |  | Cell Discharge/ Idle Low Temperature Warning | <ul style="list-style-type: none"> <li>• Insulate the battery from cold weather.</li> <li>• Warm up the battery with external heat sources.</li> </ul>  |
|                          |  | Environment High Temperature Warning         | <ul style="list-style-type: none"> <li>• Increase the airflow for efficient heat dissipation.</li> <li>• Insulate the battery from hot weather if necessary.</li> <li>• Reduce the charge/discharge current to avoid internal heat buildup if the battery is charging/discharging.</li> </ul> |
|                          |  | Environment Low Temperature Warning          | <ul style="list-style-type: none"> <li>• Insulate the battery from cold weather.</li> <li>• Warm up the battery with the heater or external heat sources.</li> </ul>  |
|                          |  | MOSFET High Temperature Warning              | <ul style="list-style-type: none"> <li>• Increase the airflow for efficient heat dissipation.</li> <li>• Insulate the battery from hot weather if necessary.</li> <li>• Reduce the charge/discharge current to avoid internal heat buildup.</li> </ul>  |
|                          |  | Balancing Circuit High Temperature Warning   | <ul style="list-style-type: none"> <li>• Increase the airflow for efficient heat dissipation.</li> <li>• Insulate the battery from hot weather if necessary.</li> <li>• Reduce the charge/discharge current to avoid internal heat buildup.</li> </ul>  |
|                          |  | Heater High Temperature Warning              | <ul style="list-style-type: none"> <li>• Restart the battery.</li> <li>• The heater MOSFET might have been damaged if the warning persists. <a href="#">Contact us</a> for help.</li> </ul>   |

# Troubleshooting

| Phenomenon  |  | Possible Causes  | Solutions   |  |
|---|--|--|---|--|
| Battery Status Indicator                            | Heater Status Indicator                            |  |   |  |
| Double Flash Yellow                                 | Lights up / Flashes According to the Heater Status | Low SOH Warning  | <ul style="list-style-type: none"> <li>Restart the battery.</li> <li>The battery is near the end of life if the warning persists. Replace the battery if necessary.</li> </ul>                                    |  |
|   |  | Battery Voltage Imbalance Warning  | <ul style="list-style-type: none"> <li>Disassemble the battery bank.</li> <li>Charge the batteries individually to bring the voltages to the same level.</li> <li>Reconnect the batteries in parallel.</li> </ul> |  |
| Charge Primary/ Secondary Overcurrent Protection    |  | <ul style="list-style-type: none"> <li>Reduce the charge current immediately.</li> <li>Discharge or restart the battery if the protection is not released automatically after 1 minute.</li> </ul>         |   |  |
| Discharge Primary/ Secondary Overcurrent Protection |  | <ul style="list-style-type: none"> <li>Reduce the discharge current immediately.</li> <li>Charge or restart the battery if the protection is not released automatically after 1 minute.</li> </ul>         |   |  |
| Short Circuit Protection                            |  | <ul style="list-style-type: none"> <li>Locate and repair the short circuits immediately.</li> <li>Charge or restart the battery if the protection is not released automatically after 1 minute.</li> </ul> |   |  |
| Reverse Polarity Protection                         |  | <ul style="list-style-type: none"> <li>Check and correct the connection polarity.</li> </ul>   |   |  |
| Pre-Charge Failure Protection                       |  | <ul style="list-style-type: none"> <li>Reduce initial DC load.</li> <li>Restart the battery if the protection is not released automatically after 1 minute.</li> </ul>                                     |   |  |
| Solid Red   |  |  |   |  |

# Troubleshooting

| Phenomenon               |  | Possible Causes                   | Solutions   |
|--------------------------|--|-----------------------------------|---|
| Battery Status Indicator | Heater Status Indicator                            |                                   |   |
| Slow Flash Red           | Lights up / Flashes According to the Heater Status | Cell Overvoltage Protection       | <ul style="list-style-type: none"> <li>• Ensure that the chargers are compatible with the lithium iron phosphate battery.</li> <li>• Ensure that the battery type is set to lithium iron phosphate and the charge voltage is set to 14.4V on the chargers. Slightly reduce the charge voltage or connect voltage sensors to the chargers to compensate for the voltage drops across the charging cables if necessary.</li> <li>• The cell overvoltage protection might be triggered near the end of the charging process due to cell voltage divergence. No risk of damage is present if the chargers are compatible with the lithium iron phosphate battery and the battery type and charge voltage are set properly on the chargers.</li> </ul> |
|                          |  | Battery Overvoltage Protection    | <ul style="list-style-type: none"> <li>• Ensure that the chargers are compatible with the lithium iron phosphate battery.</li> <li>• Ensure that the battery type is set to lithium iron phosphate and the charge voltage is set to 14.4V on the chargers. Slightly reduce the charge voltage or connect voltage sensors to the chargers to compensate for the voltage drops across the charging cables if necessary.</li> </ul>  |
|                          |  | Cell Undervoltage Protection      | <ul style="list-style-type: none"> <li>• Charge the battery immediately.</li> </ul>   |
|                          |  | Battery Undervoltage Protection   | <ul style="list-style-type: none"> <li>• Charge the battery immediately.</li> </ul>   |
|                          |  | Cell Voltage Imbalance Protection | <ul style="list-style-type: none"> <li>• Disconnect the battery from the system.</li> <li>• Leave the battery resting for 24 hours.</li> <li>• <a href="#">Contact us</a> for help if the protection persists</li> </ul>  |



# Troubleshooting

| Phenomenon               |  | Possible Causes                                  | Solutions  |
|--------------------------|--|--|--|
| Battery Status Indicator | Heater Status Indicator                            |  |  |
| Slow Flash Red           | Lights up / Flashes According to the Heater Status | AFE Overvoltage Protection                       | <ul style="list-style-type: none"> <li>Ensure that the chargers are compatible with the lithium iron phosphate battery.</li> <li>Ensure that the battery type is set to lithium iron phosphate and the charge voltage is set to 14.4V on the chargers. Slightly reduce the charge voltage or connect voltage sensors to the chargers to compensate for the voltage drops across the charging cables if necessary.</li> </ul> |
|                          |  | AFE Undervoltage Protection                      | <ul style="list-style-type: none"> <li>Charge the battery immediately.</li> </ul>  |
|                          |  | Voltage Sampling Error Protection                | <ul style="list-style-type: none"> <li>Restart the battery.</li> <li>The voltage sensor connection might have been loose if the protection persists. <a href="#">Contact us</a> for help.</li> </ul>   |
| Fast Flash Red           |  | AFE Communication Error Protection               | <ul style="list-style-type: none"> <li>Restart the battery.</li> <li>The AFE connection might have been loose if the protection persists. <a href="#">Contact us</a> for help.</li> </ul>  |
|                          |  | BMS Power Supply Malfunction Protection          | <ul style="list-style-type: none"> <li>Restart the battery.</li> <li>The BMS power supply might have been damaged if the warning persists. <a href="#">Contact us</a> for help.</li> </ul>   |
| Strobe Red               |  | Cell Charge High Temperature Protection          | <ul style="list-style-type: none"> <li>Increase the airflow for efficient heat dissipation.</li> <li>Insulate the battery from hot weather if necessary.</li> </ul>  |
|                          |  | Cell Discharge/ Idle High Temperature Protection | <ul style="list-style-type: none"> <li>Increase the airflow for efficient heat dissipation.</li> <li>Insulate the battery from hot weather if necessary.</li> </ul>  |
|                          |  | Cell Charge Low Temperature Protection           | <ul style="list-style-type: none"> <li>Insulate the battery from cold weather.</li> <li>Ensure that the heater is enabled and operating properly.</li> </ul>   |
|                          |  | Cell Discharge/ Idle Low Temperature Protection  | <ul style="list-style-type: none"> <li>Insulate the battery from cold weather.</li> <li>Warm up the battery with external heat sources.</li> </ul>   |



# Troubleshooting

| Phenomenon               |  | Possible Causes                               | Solutions  |
|--------------------------|--|---|--|
| Battery Status Indicator | Heater Status Indicator                            |   |  |
| Strobe Red               | Lights up / Flashes According to the Heater Status | Environment High Temperature Protection       | <ul style="list-style-type: none"> <li>• Increase the airflow for efficient heat dissipation.</li> <li>• Insulate the battery from hot weather if necessary.</li> </ul>                                      |
|                          |  | Environment Low Temperature Protection        | <ul style="list-style-type: none"> <li>• Insulate the battery from cold weather.</li> <li>• Warm up the battery with the heater or external heat sources.</li> </ul>   |
|                          |  | MOSFET High Temperature Protection            | <ul style="list-style-type: none"> <li>• Increase the airflow for efficient heat dissipation.</li> <li>• Insulate the battery from hot weather if necessary.</li> </ul>                                      |
|                          |  | Balancing Circuit High Temperature Protection | <ul style="list-style-type: none"> <li>• Increase the airflow for efficient heat dissipation.</li> <li>• Insulate the battery from hot weather if necessary.</li> </ul>                                      |
|                          |  | Heater High Temperature Protection            | <ul style="list-style-type: none"> <li>• Restart the battery.</li> <li>• The heater MOSFET might have been damaged if the protection persists. <a href="#">Contact us</a> for help.</li> </ul>               |
|                          |  | Heater High Temperature Hardware Protection   | <ul style="list-style-type: none"> <li>• Restart the battery.</li> <li>• The heater fuse has blown and the heater is no longer operable. But the battery can continue charging and discharging.</li> </ul>   |
|                          |  | AFE High Temperature Protection               | <ul style="list-style-type: none"> <li>• Increase the airflow for efficient heat dissipation.</li> <li>• Insulate the battery from hot weather if necessary.</li> </ul>                                      |
|                          |  | AFE Low Temperature Protection                | <ul style="list-style-type: none"> <li>• Insulate the battery from cold weather.</li> <li>• Warm up the battery with the heater or external heat sources.</li> </ul>   |
|                          |  | Temperature Sampling Error Protection         | <ul style="list-style-type: none"> <li>• Restart the battery.</li> <li>• The temperature sensor connection might have been loose if the protection persists. <a href="#">Contact us</a> for help.</li> </ul> |

# Troubleshooting

| Phenomenon               |                         | Possible Causes                         | Solutions   |
|--------------------------|-------------------------|---|---|
| Battery Status Indicator | Heater Status Indicator |   |   |
| Slow Flash Red           | Slow Flash Red          | Fuse Permanent Failure                  | <ul style="list-style-type: none"> <li>Restart the battery.</li> <li>The fuse has blown due to inrush currents if the permanent failure persists. <a href="#">Contact us</a> for help.</li> </ul>                   |
| Fast Flash Red           | Fast Flash Red          | Charge MOSFET Permanent Failure         | <ul style="list-style-type: none"> <li>Restart the battery.</li> <li>The charge MOSFET has been damaged due to voltage spikes if the permanent failure persists. <a href="#">Contact us</a> for help.</li> </ul>    |
|                          |                         | Discharge MOSFET Permanent Failure      | <ul style="list-style-type: none"> <li>Restart the battery.</li> <li>The discharge MOSFET has been damaged due to voltage spikes if the permanent failure persists. <a href="#">Contact us</a> for help.</li> </ul> |
| Strobe Red               | Strobe Red              | Cell Overvoltage Permanent Failure      | <ul style="list-style-type: none"> <li>Restart the battery.</li> <li>The battery has been severely overcharged and is no longer usable if the permanent failure persists. Replace the battery.</li> </ul>           |
|                          |                         | Cell Undervoltage Permanent Failure     | <ul style="list-style-type: none"> <li>Restart the battery.</li> <li>The battery has been severely overdischarged and is no longer usable if the permanent failure persists. Replace the battery.</li> </ul>        |
|                          |                         | Cell High Temperature Permanent Failure | <ul style="list-style-type: none"> <li>Restart the battery.</li> <li>The battery has been severely overheated and is no longer usable if the permanent failure persists. Replace the battery.</li> </ul>            |
| Double Flash Red         | Double Flash Red        | Low SOH Permanent Failure               | <ul style="list-style-type: none"> <li>Restart the battery.</li> <li>The battery reaches the end of life if the permanent failure persists. Replace the battery.</li> </ul>   |

# Troubleshooting

| Phenomenon   |                         | Possible Causes                           | Solutions  |
|--|-------------------------|---|--|
| Battery Status Indicator                                       | Heater Status Indicator |   |  |
| Lights up/<br>Flashes<br>According to<br>the Battery<br>Status | Solid Red               | Heater<br>Malfunction<br>Warning          | <ul style="list-style-type: none"> <li>Restart the battery.</li> <li>The heater might have fell off due to vibration if the warning persists. <a href="#">Contact us</a> for help.</li> </ul>  |
|  |                         | Heater Turns<br>on and off<br>Repeatedly  | <ul style="list-style-type: none"> <li>Ensure that the chargers are able to deliver a charge current greater than 15A to each battery in the battery bank. The heater is unable to operate properly with low current chargers.</li> <li>Ensure that the chargers are able to deliver a stable charge current. The heater is unable to operate properly with PWM charge controllers.</li> </ul> |
| Unable to Turn on Battery                                      |                         | Cell Undervoltage<br>Permanent<br>Failure | <ul style="list-style-type: none"> <li>The battery has been severely overdischarged and is no longer usable. Replace the battery.</li> </ul>   |

# Emergency Responses

Fire

Flooding

Smell

In the event of any threat to health or safety, always begin with the steps below before addressing other suggestions.

- Immediately contact the fire department or other relevant emergency response team.
- Notify all people who might be affected and ensure that they can evacuate the area.



## WARNING

- ONLY perform the suggested actions below if it is safe to do so.

### Fire

1. Disconnect the battery from the system.
2. Turn the battery off.
3. Put out the fire with a fire extinguisher. Acceptable fire extinguishers include water, CO<sub>2</sub>, and ABC.



## WARNING

- DO NOT use type D (flammable metal) fire extinguishers.

### Flooding

1. Stay out of the water if any part of the battery or cable is submerged.
2. Disconnect the battery from the system.
3. Turn the battery off.
4. Protect the battery by finding and stopping the source of the water and pumping water away if possible.

### Smell

1. Disconnect the battery from the system.
2. Turn the battery off.
3. Ensure that nothing is in contact with the battery.
4. Ventilate the installation space.

# Technical Support

For additional support, contact the Renogy technical support team through [renogy.com/contact-us](https://renogy.com/contact-us). Have the following information available when contacting Renogy.

- Owner name
- Contact information
- Order number
- Purchase channel
- Serial number
- Brief description of the issue



Visit [renogy.com](https://renogy.com) to find relevant documentation or get more support.

**US** [www.renogy.com](https://www.renogy.com)

**CN** [www.renogy.cn](https://www.renogy.cn)

**UK** [uk.renogy.com](https://uk.renogy.com)

**CA** [ca.renogy.com](https://ca.renogy.com)

**AU** [au.renogy.com](https://au.renogy.com)

**JP** [renogy.jp](https://renogy.jp)

**FR** [fr.renogy.com](https://fr.renogy.com)

**DE** [de.renogy.com](https://de.renogy.com)

**ES** [es.renogy.com](https://es.renogy.com)

**KR** [kr.renogy.com](https://kr.renogy.com)

# Technical Specifications

| General                              |   |
|--------------------------------------|---|
| Dimension                            | 17.99 x 12.95 x 10.52 inch / 457.0 x 329.0 x 267.2 mm<br>(Exclude Cable Glands and Integrated Cables) |
| Weight                               | 112.44 lbs. / 51.0 kg   |
| Operating Environment Temperature    | 59°F to 86°F / 15°C to 30°C (Recommended)<br>-4°F to 122°F / -20°C to 50°C (Extreme)                  |
| Operating Relative Humidity          | 5% to 95%   |
| Operating Altitude                   | <9842.5 ft. / <3000 m   |
| Charge Temperature                   | -4°F to 122°F / -20°C to 50°C   |
| Discharge Temperature                | -4°F to 140°F / -20°C to 60°C   |
| Storage Temperature                  | -4°F to 113°F / -20°C to 45°C   |
| Storage Relative Humidity            | 5% to 95%   |
| Input/Output Connector               | Gray Anderson 350 Connector   |
| Integrated Cable Size                | 4/0 AWG / 107 mm <sup>2</sup>   |
| Integrated Cable Length              | 23.62 inch / 600 mm (Include Anderson Connector and Cable Glands)                                     |
| Communication Interface              | LP16 Port (7-Pin), Bluetooth Module   |
| Communication Protocol               | RV-C (LP16 Port), MODBUS (Bluetooth Module)   |
| Housing Material                     | Aluminum  |
| Protection Rating                    | IP65  |
| Cooling Method                       | Passive Cooling   |
| Electrical                           |   |
| Battery Type                         | Lithium Iron Phosphate  |
| Nominal Voltage                      | 12.8V   |
| Rated Capacity                       | 400Ah (0.2C, 25°C)  |
| Rated Energy                         | 5.12KWh (0.2C, 25°C)  |
| Maximum Continuous Charge Current    | 5A (-20°C to 0°C)<br>200A (0°C to 15°C / 50°C to 55°C)<br>300A (15°C to 50°C)                         |
| Maximum Continuous Discharge Current | 350A (-20°C to 60°C)  |
| Cycle Life                           | 3800 Cycles (80% DOD, 80% EOL, 0.2C, 25°C)  |
| Internal Resistance                  | <10mΩ   |
| Connection Method                    | Parallel (Up to 8)  |

# Technical Specifications

|                              |  |
|------------------------------|--|
| Self-Discharge Rate          | ≤18%/Month (Turned On)<br>≤1.5%/Month (Turned Off) |
| <b>Charger Setting</b>       |  |
| Boost Voltage                | 14.4V  |
| Float Voltage                | 14.4V/Disable                                      |
| Equalization Voltage         | 3500W  |
| Tail Current                 | 20A  |
| Peukert Exponent             | 1.01   |
| <b>Heater</b>                |  |
| Heater Operating Temperature | >-20°C / >-4°F                                     |
| Heater Power Rating          | 200W   |
| Heater Heating Rate          | 5°C/h / 9°F/h                                      |

# Dimensions

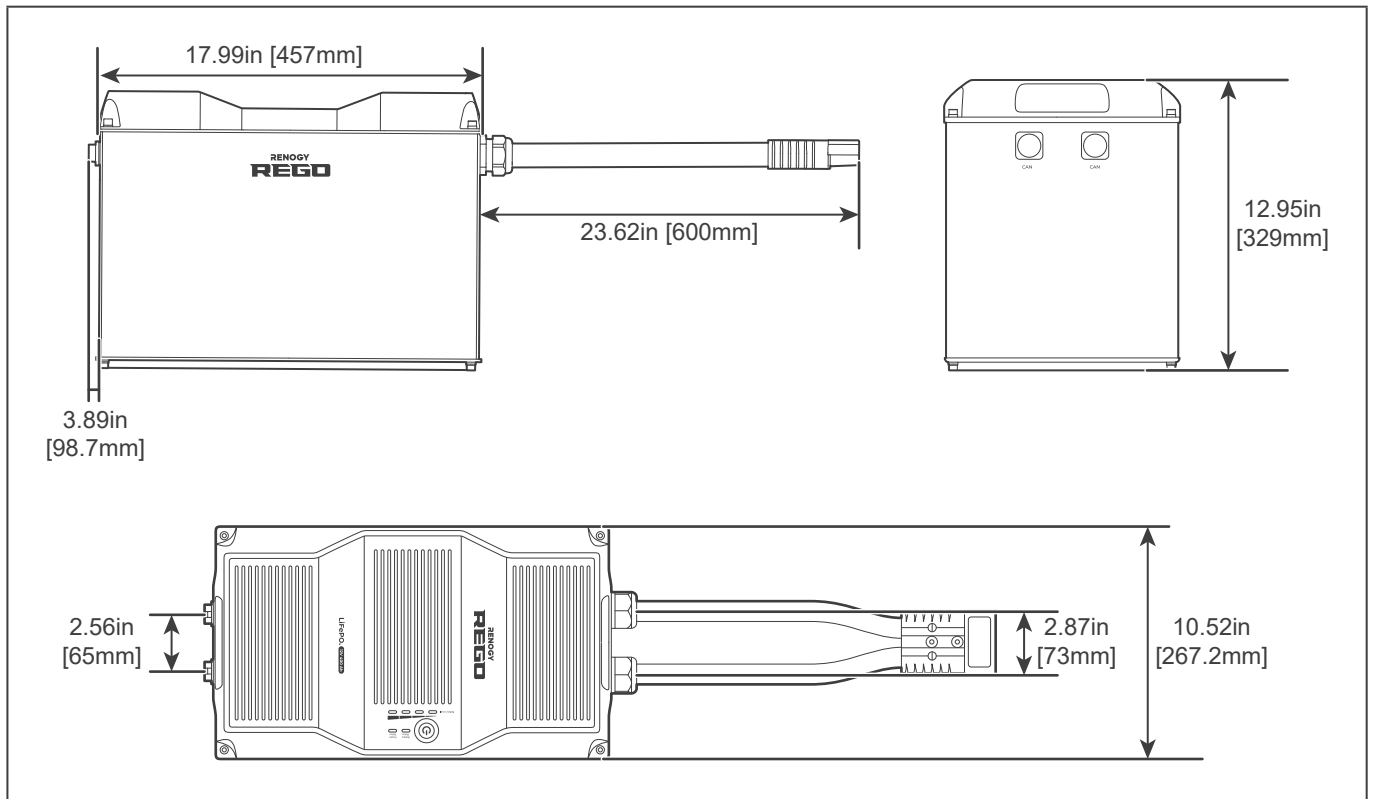

## NOTE

- The dimension tolerance is  $\pm 0.02$  inch ( $\pm 0.5$  mm)



## FCC Statement

This device complies with Part 15 of the FCC Rules. FCC ID: 2ANPBRMLP4-G2. Operation is subject to the following two conditions:

- (1) This device may not cause harmful interference.
- (2) This device must accept any interference received, including interference that may cause undesired operation.

This equipment has been tested and found to comply with the limits for a Class B digital device, pursuant to Part 15 of the FCC Rules. These limits are designed to provide reasonable protection against harmful interference in a residential installation. This equipment generates, uses and can radiate radio frequency energy and, if not installed and used in accordance with the instructions, may cause harmful interference to radio communications. However, there is no guarantee that interference will not occur in a particular installation. If this equipment does cause harmful interference to radio or television reception, which can be determined by turning the equipment off and on, the user is encouraged to try to correct the interference by one or more of the following measures:

- (1) Orient or relocate the receiving antenna.
- (2) Increase the separation between the equipment and receiver.
- (3) Connect the equipment into an outlet on a circuit different from that to which the receiver is connected.
- (4) Consult the dealer or an experienced radio/TV technician for help.

## FCC Radiation Exposure Statement

This equipment complies with FCC radiation exposure limits set forth for an uncontrolled environment. This equipment should be installed and operated with minimum distance 20cm between the radiator & your body.

Join the Renogy Power Plus Community  
by downloading the DC Home App.  
Find your e-warranty here, and more.

