

User Manual



12/24V

LiFePO4 Battery

Instructions for Use of 12/24V LiFePO₄ Battery

1 Overview

This manual is meant for the installer and the user of the Li-ion battery. Only qualified, certified personnel may install and perform maintenance on the Li-ion battery.

This manual contains instructions of Vision’s 12V/24V lithium iron phosphate battery connection methods, precautions for use and storage, troubleshooting, and general guidelines for the convenience of customers.

2 Features

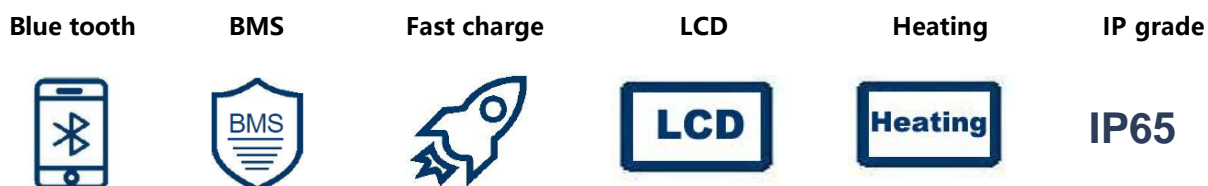

3 Operating conditions

Operating temperature	Charge: -4°F—113°F (-20°C—45°C)
	Discharge: -4°F—131°F (-20°C—55°C)
Storage temperature	20°C~30°C(68°F~86°F)
Heating function	Charging heating
	<33.8°F, ON; >42.8°F, OFF
Voltage window	12V series: 10.8-14.6V
	24V series: 21.6-29.2V

4 12V/24V battery F2 (0.250) terminal products

Terminal diagram

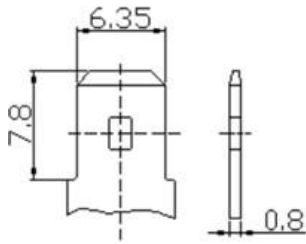

① Wiring diagram for series connection

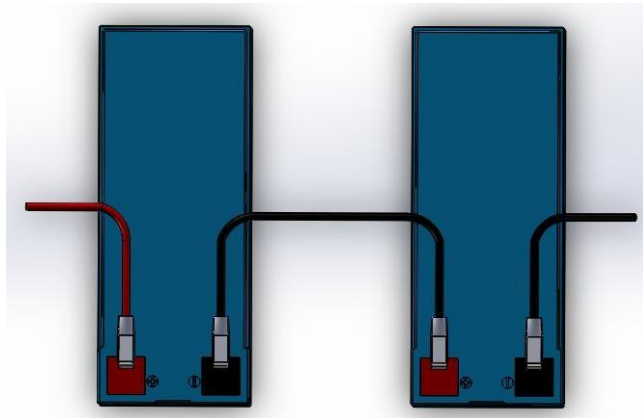
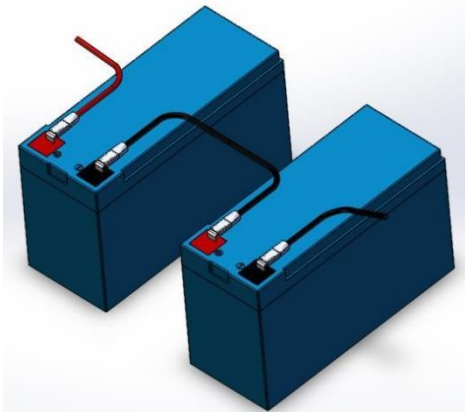

When battery is fixed in series, it is recommended to use the plug-in method for the connection. If the vibration is relatively large during use, it is recommended to use welding to connect.

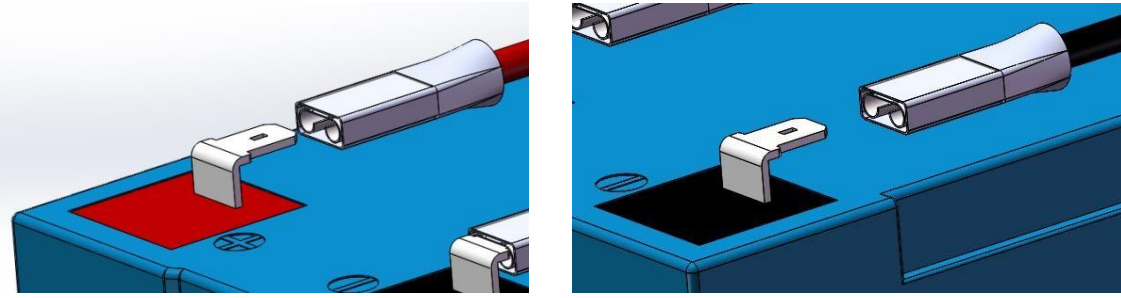

② Wiring diagram for parallel use

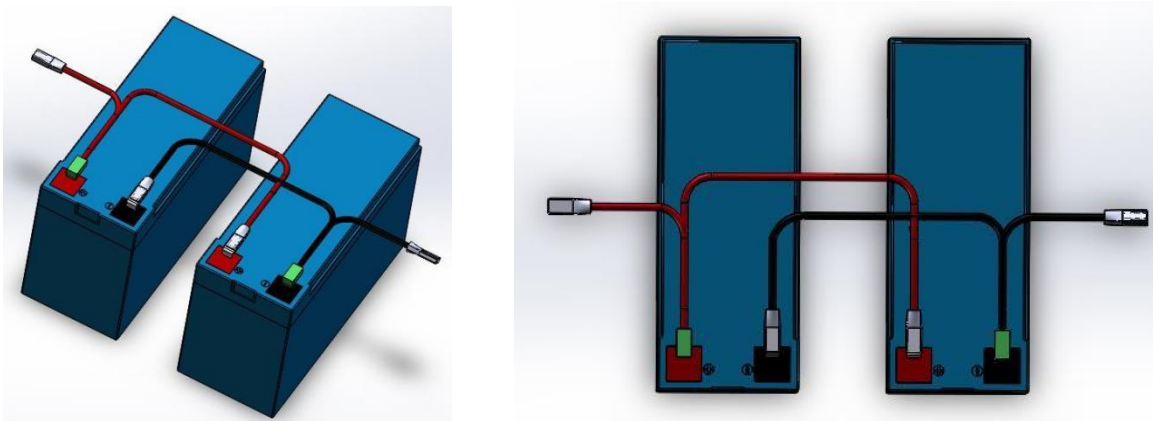

In parallel, it is recommended to use welding to connect.

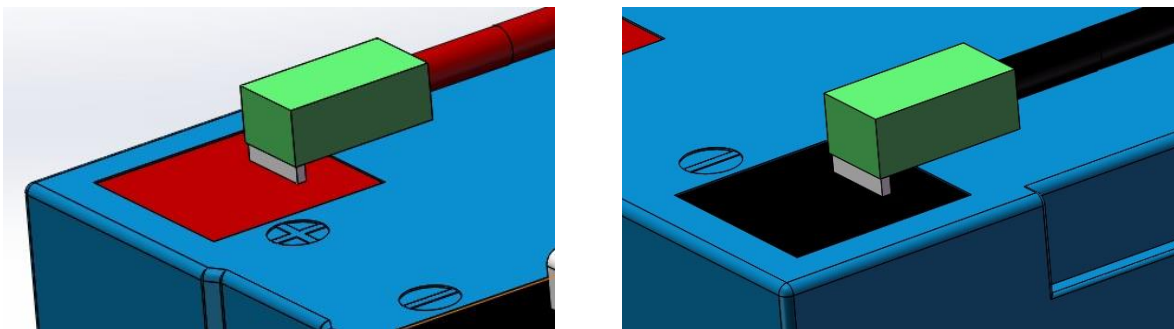

5 12V/24V battery M5/M6/M8 terminal products

Terminal diagram

Locking bolt assembly: 1 screw + 2 flat washers + 1 Lock Washer

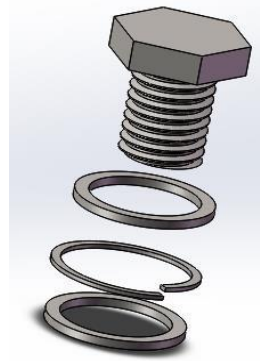
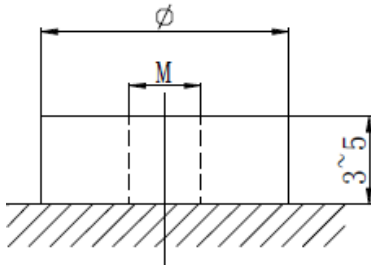

TYPE	F11	F12	F13
M	6	8	5
ϕ	14	16	12
Tightening torque	8N•m	10N•m	6N•m

Schematic diagram of the bolt-locking-connector, the flat washer and the Lock Washer cannot be placed between the connector and the battery terminal.

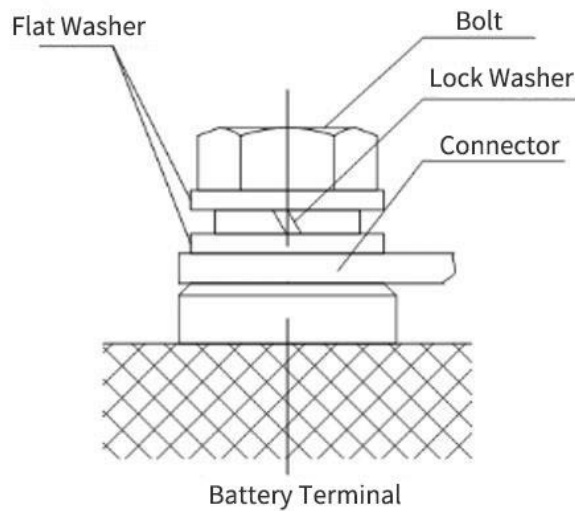

Wiring diagram for series connection

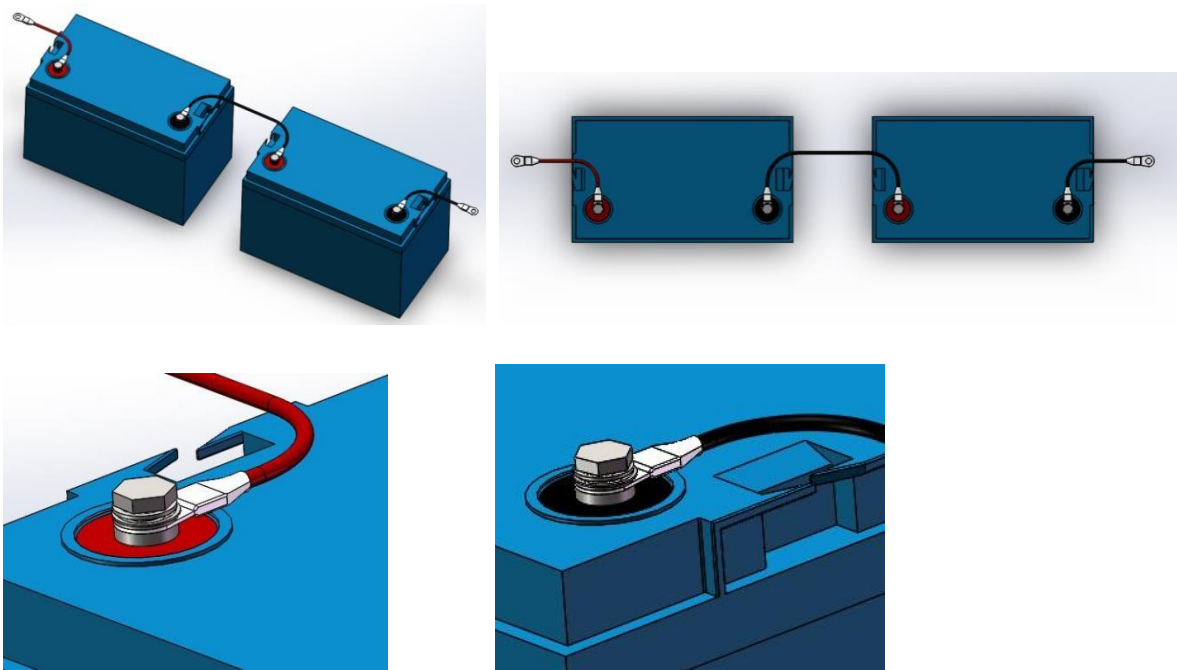

IMPORTANT: Maximum serial connection Voltage CANNOT exceed 58.4V. So up to four 12V batteries can be connected in Serial.

② Wiring diagram for parallel use

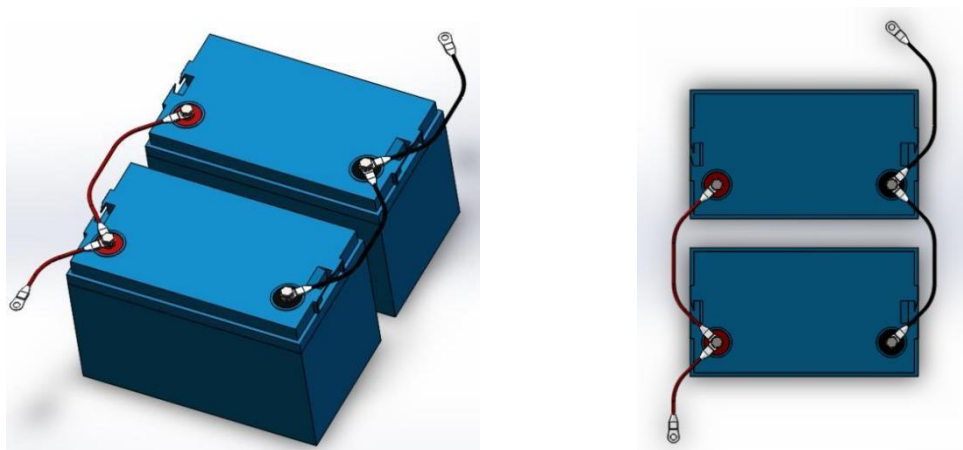

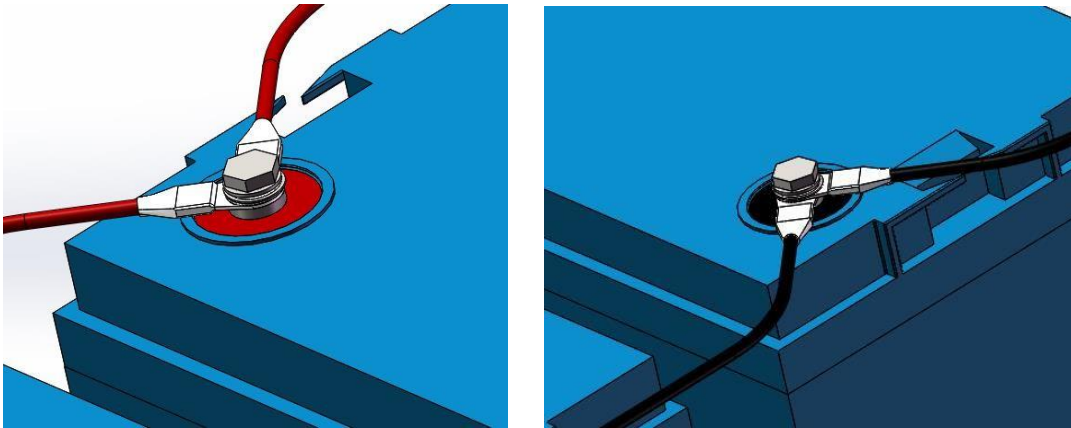

6 Bluetooth function

Bluetooth APP support both iOS and Android system. iOS users can download and install “LL Battery Monitor” from APPSTORE, Android users download and install “LL Battery Monitor” from Google Play Store.

- ① Install “LL Battery Monitor” APP, enable Bluetooth on cell phone, click “LL Battery Monitor” icon to enter program.
- ② All batteries with Bluetooth in the available range will be indicated as below, match battery by the Bluetooth ID that pasted on cover of battery.



- ③ Choose the battery that need be checked, enter monitoring interface, also can switch to celldata

interface and warning interface.

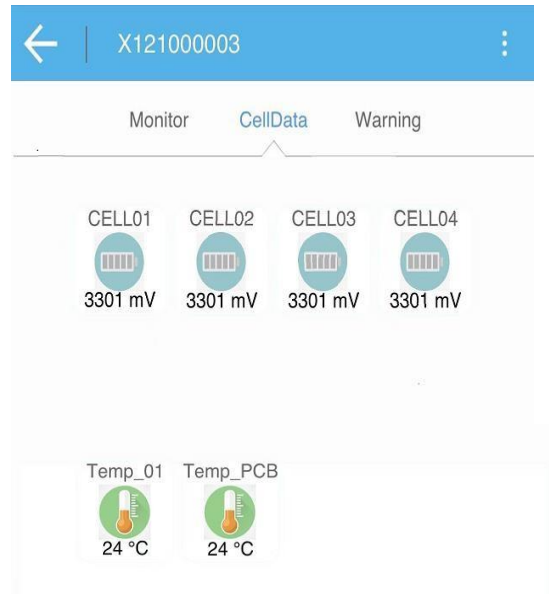

Warning interface for device X121000003. The interface is divided into Voltage and Temperature sections. The Voltage section lists Pack OV, Cell OV, Pack UV, Cell UV, Charge OC, Discharge OC, Low Capacity, and Discharge SC. The Temperature section lists Charge OT, Discharge OT, Charge UT, Discharge UT, Temp Anomaly, and MosFet OT.

Voltage	
Pack OV	Cell OV
Pack UV	Cell UV
Charge OC	Discharge OC
Low Capacity	Discharge SC
Temperature	
Charge OT	Discharge OT
Charge UT	Discharge UT
Temp Anomaly	MosFet OT

④ From drop-down menu, can go the interface of “changing name”, “Setting”, “More information”, “Exit menu”.



Change Name: Can change name of the battery.

Setting: Here only indicates parameter of protection of voltage, current and temperature, information only can be viewed, but not be modified.

More information: Include voltage, current and temperature information.

Exit Menu: to exit APP.

Note: In case the APP fails to connect to the Bluetooth of battery, please completely exit the APP and try to reconnect.

7 LCD Display

Press the button on LCD, first indicates voltage of battery, press second time indicates SOC, then indicates voltage of each battery cell by each pressing. Those information will loop in order.



8 Cautions

The battery is in half-charged state when leaving the factory, please fully charge it before use.

When battery is stored for a long time, ensure that it is half-charged. In order to ensure the best performance of the battery, it should be charged and discharged every three months.

Before the batteries are used in series or in parallel, they need to be fully charged separately with a special charger for lithium iron phosphate batteries, and the voltage difference should not exceed 0.1V. The recommended charging voltage is 14.4V~14.6V for 12V batteries, 28.8V~29.2V for 24V batteries, and the recommended charging current is 0.2C~0.5C.

Do not mix batteries made by different manufacturers, different types of batteries, and mix new and old batteries.

When installing, it is best to ensure a certain heat dissipation gap between the batteries, and the recommended gap is $\geq 20\text{mm}$.

It is strictly forbidden to immerse the battery in water. When not in use, it should be stored in a cool and dry environment.

It is strictly forbidden to throw the battery into the fire to avoid explosion or other dangers.

It is strictly forbidden to use the battery with the positive and negative poles reversed. It is strictly forbidden to connect the battery directly to the power socket, and it is forbidden to short-circuit the positive and negative poles of the battery.

Do not charge or discharge the battery with heat, swelling, deformation or leakage.

It is forbidden to pierce the battery with nails or other sharp objects, and it is forbidden to throw, step on, knock, hit the battery, etc.

Appendix

Common Issue and Solution During Use of LiFePO₄ Battery

Issue	Reason	Solution
The battery cannot be charged	The charger is connected reversely.	Connect the charger correctly.
	Charger has low voltage disable function.	Connect a fully charged lead-acid battery or lithium iron phosphate battery with the same rated voltage in parallel for boost charging. Switch to another lithium iron phosphate battery charger without low voltage disable function.
	Battery is in high voltage.	Charging over-voltage protection: disconnect the circuit and wait, when cell voltage is ≤ 3.50 and the battery voltage drops to 13.8~14.0V, the protection will be automatically released or release the protection by 5A discharge.
	High temperature inside the battery.	High temperature charging protection: the protection will be released when battery inside temperature drops to 50~60°C.
	Low temperature inside the battery.	Low temperature charging protection: the protection will be released when battery inside temperature rises to above 5°C.
	The charging current is too high.	Charging over-current protection: disconnect the circuit, wait for about 1 minute for self-recovery or release the protection by 5A discharge.
	Long-term storage after the battery is discharged will cause the BMS to fail to activate under low-voltage conditions.	The battery must be charged within 6 days after fully discharged, otherwise the battery needs to be returned to the factory for dismantling and repair.
	BMS failure.	The battery needs to be returned to the factory for

		dismantling and repair.
The battery cannot be discharged	Battery is in low voltage.	Discharge low voltage protection: disconnect the circuit and wait, when the cell voltage rises to 2.60V~3.00V and the battery voltage rises to 10.8~12V, the protection will be automatically released or release the protection by 5A charge.
	High temperature inside the battery.	High temperature discharging protection: the protection will be released when battery inside temperature drops to 50~60°C(122°F~140°F)
	Low temperature inside the battery.	Low temperature discharging protection: the protection will be released when battery inside temperature rises to above -15°C (-59°F).
	The discharging current is too high.	Discharging over-current protection: disconnect the circuit, wait for about 1 minute for self-recovery or release the protection by 5A charge.
	The external load is short-circuited.	Automatically recover about 1 minute after the load is removed
	BMS failure.	The battery needs to be returned to the factory for dismantling and repair.
Battery discharge time is short	The cells in the battery pack are short-circuited slightly, resulting in large self-discharge.	The battery needs to be returned to the factory for disassembly, and the bad battery cell needs to be replaced with new one.
	There are big differences in cells consistency, and BMS detects the low voltage of the backward cells and terminates discharge early.	The battery needs to be returned to the factory for disassembly, and the backward cell needs to be replaced with new one.
The battery can't be fully charged	There are big differences in cells consistency, and BMS detects the high-voltage of individual cells, and terminates charge early.	The battery needs to be returned to the factory for disassembly, and the backward cell needs to be replaced with new one.

<p>Low voltage after the battery is stored for a short time</p>	<p>The cells in the battery pack are short-circuited slightly, resulting in large self-discharge.</p>	<p>The battery needs to be returned to the factory for disassembly, and the backward cell needs to be replaced with new one.</p>
<p>Charging voltage range</p>	<p>/</p>	<p>12V: 14.4-14.6V 24V: 28.8-29.2V</p>
<p>Discharge cut-off voltage</p>	<p>/</p>	<p>12V: $\geq 10.8V$ 24V: $\geq 21.6V$</p>